

NANDI COUNTY

STD 2 - END-TERM 1

MATHEMATICS

Name School

Count

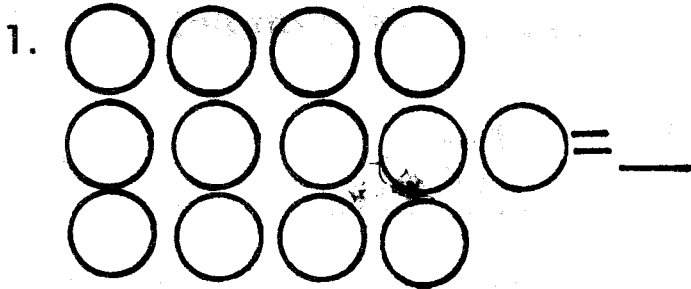

2. $8 + 5 + 5 =$ _____

3. $27 =$ _____ tens _____ ones.

4.
$$\begin{array}{r} 98 \\ - 6 \\ \hline \end{array}$$

Write in words.

5. $47 =$ _____

6. $59 + 18 =$ _____

7. $\square - 20 = 39$

8. What is the next number in the pattern?

5, 10, 15, _____

9.
$$\begin{array}{r} 260 \\ - 140 \\ \hline \end{array}$$

10. $3 + 3 + 3 =$ _____ \times _____ $=$ _____

Write in symbols.

11. Eighty three _____

12.
$$\begin{array}{r} 324 \\ + 243 \\ \hline \end{array}$$

13. What is the next number in the pattern?

70, 68, 66, _____

14. $6 + 23 =$ _____

15. Divide

$20 \div 5 =$ _____

16. We wake up in the _____
(evening, noon, morning)

17. $9 =$ _____ tens _____ ones.

18. $10 \times 6 =$ _____

19.



= _____ tens _____ ones.

20. Which number comes before 39? _____

21. $20 - \square = 10$

22. Share 8 bananas between 2 children = _____

23.

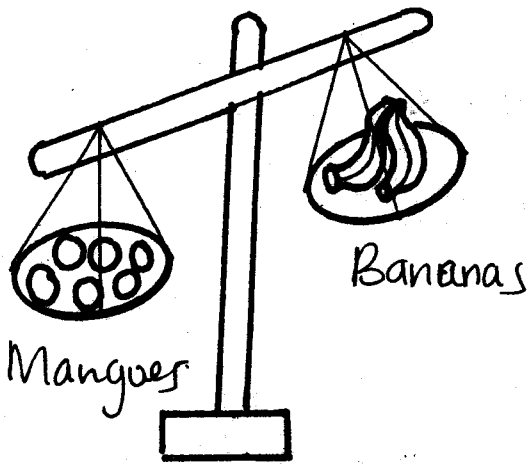

Which one are lighter? _____

24.

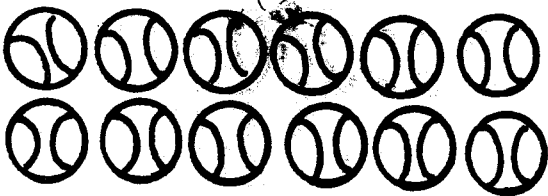

2 x _____ = _____

25. The length of our classroom door is _____ metres. (1, 2, 3)

26. Arrange from smallest to the biggest. 210, 96, 148, 63.

27. 8 hundreds 0 tens 4 ones

= _____

28.

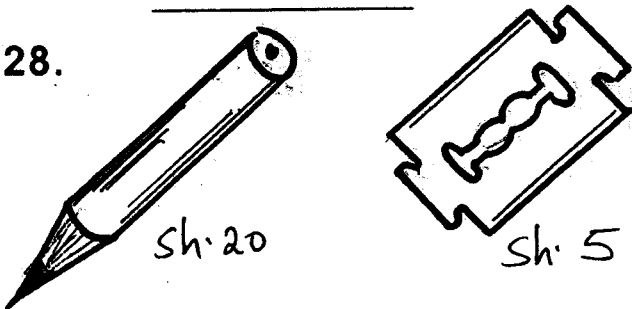

How much will I pay for 2 pencils and a razorblade?

29. 10 hens have _____ legs.

30. $80 - 50 =$ _____

31. Name the shape.

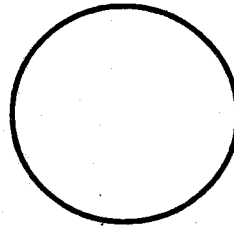

(oval, circle, triangle)

32. 208

+ 41

33. Wednesday, Thursday, Friday,

(Saturday, Sunday, Monday)

34. $3 \times \square = 21$

35. 59

- 0

36. 13

24

+ 49

37. 8 tens + 1 ten = _____ tens,

38. $15 + \square = 38$

39. 500

- 300

40. $18 \div \square = 6$

NANDI COUNTY

STD 2 - END-TERM 1

ENGLISH

Name School

Dictation.

1. _____
2. _____
3. _____
4. _____
5. _____

Name the pictures.

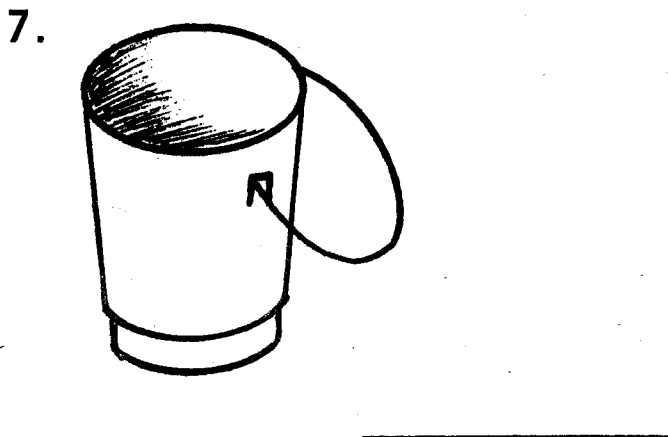
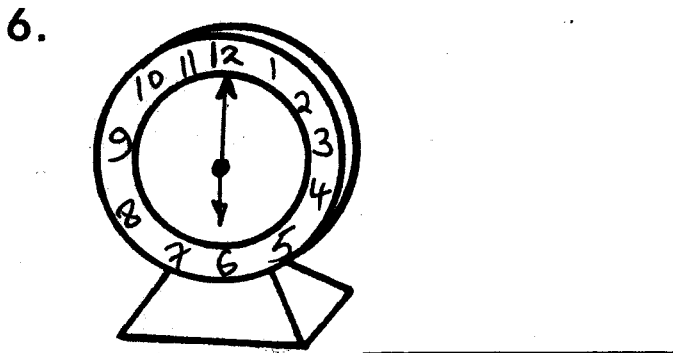

(basket, bucket, face, clock)

Write in plurals.

8. Branch - _____
9. Pineapple - _____
10. Store - _____
11. Sheep - _____

Write well

12. ckne - _____
13. verdri - _____
14. wnto - _____

Use "this" or "these"

15. _____ are mangoes.
16. _____ is an aeroplane.
17. What is _____?
18. I like _____ fruits.

Write the opposites.

19. Morning - _____
20. Sunrise - _____
21. Black - _____

(night, sunset, evening, white)

Add -ing

22. Write - _____
23. Clean - _____
24. Sit - _____

Join the words.

25. Black - _____
26. Police - _____
27. Break - _____
(white, fast, man, board)

Write in words or figures.

28. 88 - _____
29. Forty nine - _____

Use "under", "in", or "on"

30.

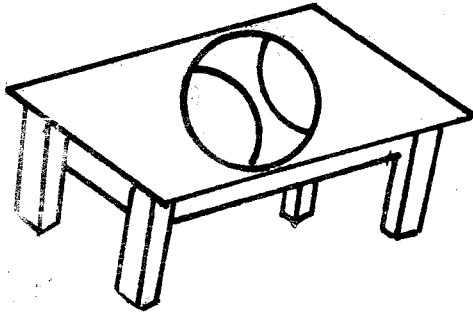

The ball is _____ the table.

31.

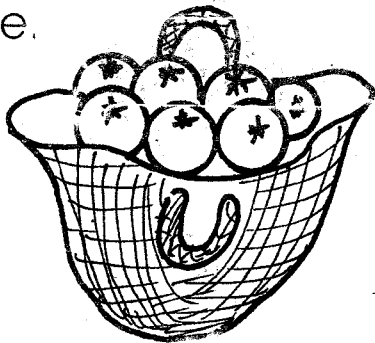

The oranges are _____ the basket.

Write in past tense.

32. Wave - _____
33. Talk - _____
34. Sweep - _____

Fill in the missing letters.

35. pl _____ t _____
36. C _____ mp _____ und

Complete the sentences.

37. Is there _____ in the classroom? (anybody, nothing)
38. _____ is the forth month of the year. (January, March, April)
39. The children of my aunt are my _____ (uncles, brothers, cousins)
40. A house of a dog is called _____ (shed, kennel, house)

NANDI COUNTY
DARASA LA PILI MUHULA WA KWANZA
KISWAHILI

Jina.....*Shule*.....

Imla.

1. _____
2. _____
3. _____
4. _____
5. _____

Andika wingi.

6. Chungwa - _____
7. Kalamu - _____
8. Mnyama - _____

Tengeneza majina.

9. chaku - _____
10. ronyafu - _____
11. timakai - _____

Andika majina ya picha.

12.

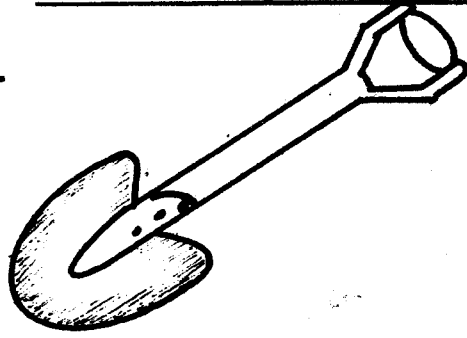

13.

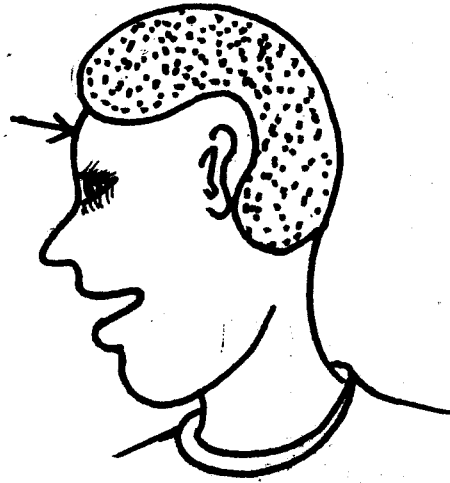

(kijiko, paji, paja, kolego)

Andika kwa nambari au maneno.

14. Tisini na sita _____

15. 79 - _____

Tumia '-etu'

Mfano; Darasa letu.

16. Mtoto - _____
17. Vitabu - _____
18. Shule - _____

Tumia (.) au (?)

19. Huu ni mkoba wa nani _____
20. Sisi tunasoma _____

Chora maumbo haya.

21. Duara

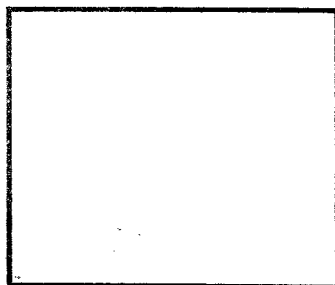

22. Mstatili

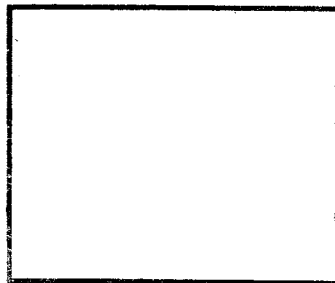

Andika kinyume

23. Mchana - _____
24. Ingia - _____
25. Lala - _____

Tumia 'ta', 'na' au 'li'

26. Jana m_____soma vizuri sana.
27. Kamau na Njeri wa_____enda
Nairobi wakifunga shule.

Kamilisha sentensi.

28. Mwanangu analia mwituni

29. Bubu anayenena _____
30. Asante ya punda ni _____

31. Walimu shuleni huandika
majina ya wanafunzi kwenye

(rejista, mateke, shoka,
majilisi, maktaba, kalamu)

Jaza mapengo.

32. Ng _____m _____a
33. v _____dol _____
34. kil _____mb _____

Tumia herufi kubwa au ndogo.

35. SHANGAZI - _____
36. trekta - _____

Jaza pengo.

37. Damu ni ya rangi _____
38. Tunaosha mikono kwa _____
na maji.
39. _____ ni siku ya kwanza
ya wiki.
40. _____ hutupa mwangaza
usiku.
(Jumatatu, Jumapili, sabuni,
jua, mwezi, nyekundu)

NANDI COUNTY
STD 2 - END - TERM 1
SCIENCE

Name School

1.

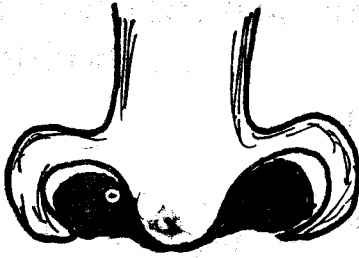

This is a sense organ for
_____ (hearing,
seeing, smelling)

2.

_____ is a personal item.
(socks, pullover, shirt)

3.

Removing of unwanted plants
is called _____
(planting, weeding, watering)

4.

A jacket is used when the
weather is _____
(cold, hot)

5.

A zebra is a _____ animal.
(domestic, wild, home)

6.

The sense of _____ is
used when crossing the road.
(taste, smell, sight)

7.

A pit latrine must be _____
to keep away flies. (opened,
covered, washed)

8.

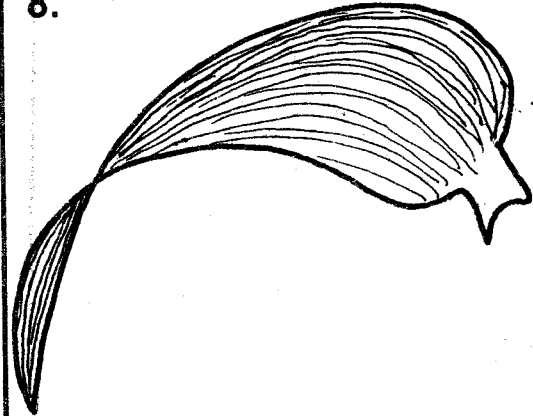

_____ has this leaf.
(Maize, Banana, Arrowroots)

9.

An _____ is used to
protect us from rain. (vest,
umbrella, coat)

10.

A _____ is a harmful animal.
(snake, cow, goat)

11.

When it is dry we _____
our plants. (uproot, water,
plant)

12.

A _____ is a source of light,
(housefly, bee, firefly)

13.

We can eat a _____ before
cooking. (carrot, maize,
beans)

14.

We can write or draw on the
_____ (water, soil, milk)

15. We _____ a whistle to produce sound. (**beat, pluck, blow**)

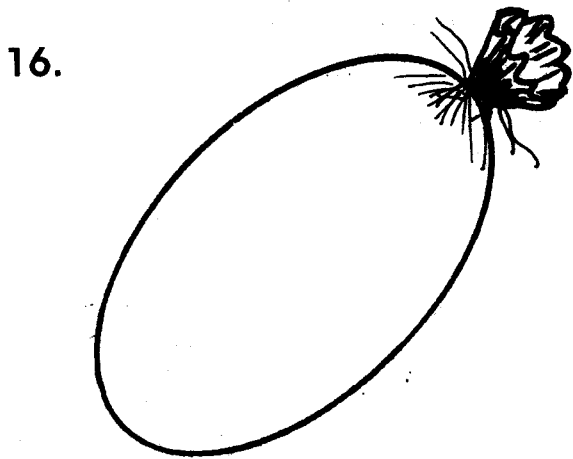

16.

There is _____ in the balloon.
(**air, water, food**)

17. A wheelbarrow has _____ wheel. (**many, 2, 1**)

18. A comb and _____ are used to comb our hair. (**toothbrush, hairbrush, chewed stick**)

19. New plants grow from _____. (**seeds, leaves, flowers**)

20.

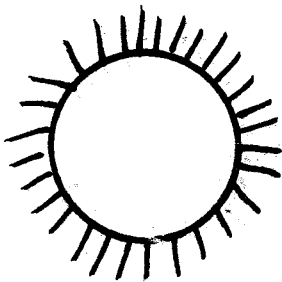

The weather is _____
(**rainy, windy, sunny**)

21. A fish gives us _____. (**milk, skin, meat**)

22. We eat the _____ of a sugarcane. (**leaves, stem, roots**)

23. We clean a toothbrush with _____ water after using. (**clean, soapy, dirty**)

24. Playing with soil can make our _____ sick. (**hands, eyes, legs**)

25.



The part marked B is called _____ (**ear, tail, horn**)

26. The _____ is between the head and the shoulders. (**chest, neck, arm**)

27. Many leaves are _____ in colour. (**red, blue, green**)

28. We sprinkle water on _____ floor before sweeping. (**earthen, cemented, clean**)







29. Dirty water smells _____. (**good, bad**)

30. An _____ is a source of water. (**bucket, tap, ocean**)

NANDI COUNTY STD 2 - END-TERM 1 SOCIAL STUDIES

Name School

1. Jembes are kept in the _____ (staff-room, store, class)
2. Running round the field is called _____ (jumping, athletics, skipping)
3. We need _____ in school to learn. (textbook, balls, trees)
4. _____ are people driving vehicles on the road. (Cyclists, Pedestrians, Motorists)

Day	Morning	Afternoon
Mon		
Tue		
Wed		

5. The weather was _____ on Tuesday afternoon. (cloudy, rainy, windy)

6. It was _____ on Monday. (rainy, cloudy, sunny)
7. _____ was a cloudy day in the morning. (Monday, Wednesday, Tuesday)
8. We play in the _____. (playground, classroom, kitchen)

9.

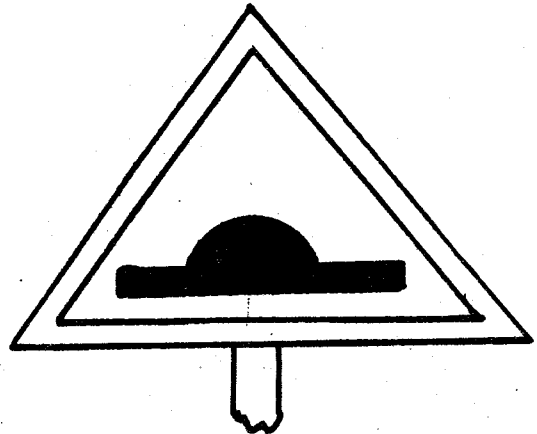

This road sign means _____. (bend, bump, stop)

10. The _____ employs teachers to our schools. (government, pupils, friends)
11. "Tufanye sote bidii" is found in the _____ (Lord's prayer, national anthem, grace)

12. _____ makes our school look beautiful. (stones, papers, flowers)

13. Lack of _____ is a problem in many schools. (flowers, books, visitors)

14. _____ colour on the traffic lights means 'stop'. (green, orange, red)

15. A hut is a _____ house. (modern, traditional)

16. A _____ is a room where food is cooked. (kitchen, bedroom, toilet)

17. _____ is a harmful animal. (wasp, butterfly, grasshopper)

18.



This feature is called _____ (mountain, hill, river)

19. We should not eat _____ fruits. (sweet, poisonous, good)

20. A _____ is a tool used in the shamba. (spoon, rake, knife)

21. School rules help us to do the _____ things. (wrong, right, bad)

22. _____ are dangerous insects. (Wasps, Termites, Butterfly)

23. Food, _____ and clothes are basic needs. (car, shelter, pests)

24. Bad things like beating children is called _____. (child rights, child labour, child abuse)

25. Every home must have a _____. (radio, latrine, car)

26. The wall of a manyatta is made of _____. (stones, cow-dung, mud)

27. Our class is a _____ house. (permanent, temporary, traditional)

28. A _____ in class shows what we learn everyday. (register, calendar, time-table)

29. The mother of my mother is my _____. (grandfather, grandmother, mother)

30. People are happy on a _____ ceremony. (funeral, burial, wedding)

NANDI COUNTY

STD 2 - END-TERM 1

C.R.E.

Name School

1. Aunts and uncles are my _____ (parents, relatives, brothers)
2. The name of our headteacher is _____
3. _____ were created by God. (houses, pots, plants)
4. The bible has _____ books. (39, 27, 66)
5. Prophet _____ told about the birth of Jesus. (Isaiah, David, John)
6. We should say _____ when given something. (sorry, thankyou, excuse me)
7. _____ is a way of worshipping God. (Stealing, Crying, Praising)
8. Naomi had _____ sons. (4, 3, 2)
9. God is _____ when we obey our parents. (happy, sad, unhappy)
10. We should _____ our environment. (destroy, take care)
11. The writers of the bible were guided by _____ (God, men)

12. The _____ were the first people to see baby Jesus. (kings, neighbours, shepherds)
13. _____ is a way of showing thankfulness to our neighbours. (Sharing, Fighting, Abusing)
14. The Lord's prayer was taught by _____ (James, Jesus, John)
15. Pupils in my class are my _____ (schoolmates, classmates, parents)
16. Draw:-

Butterfly
17. Jesus healed _____ lepers. (5, 9, 10)
18. _____ was a gift given to Jesus by the wisemen. (money, myrrh, soda)
19. In the Lord's prayer we say 'our _____ in heaven.' (mother, friend, father)
20. Children are _____ from God. (gifts, fruits, talents)