

PART I: SOCIAL STUDIES

BETA AREA

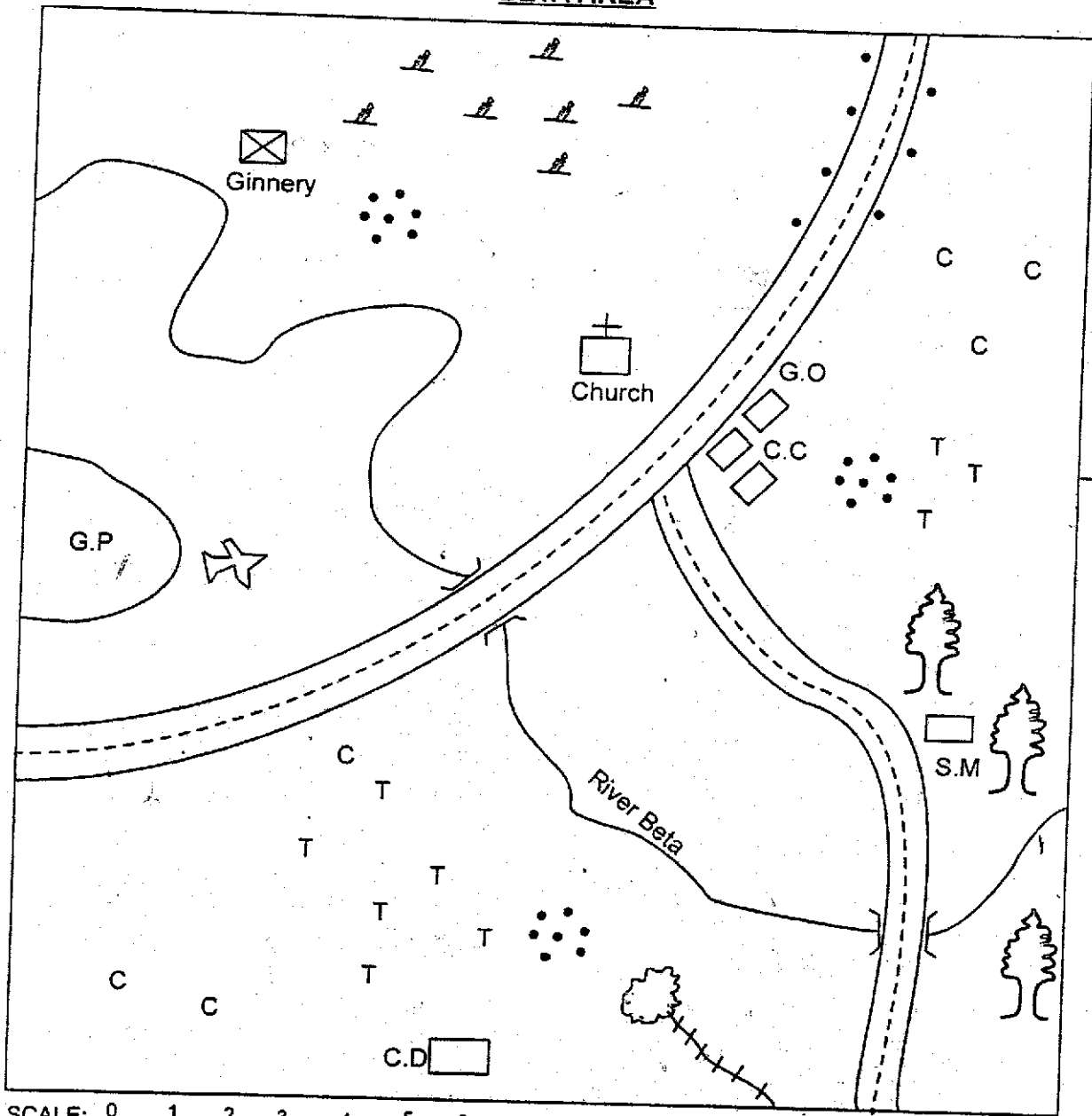

SCALE: 0 1 2 3 4 5 6 7 8 9 10 km

KEY

	Forest	C.C	Chief's camp		Scrub
	Tarmac road	C.D	Cattle dip		Settlement
	Permanent buildings	G.O	Governor's office		Quarry
G.P	Game park		Air strip		Railway line
T T	Tea	C C	Coffee		Saw mill

Study the map of Beta area and answer questions 1-7

1. The land in Beta area slopes towards:-
 - A. South East
 - B. North East
 - C. North West
 - D. South West
2. Which of the following breeds of cattle is **not** likely to be kept in Beta area?
 - A. Friesian
 - B. Hereford
 - C. Jersey
 - D. Guensey
3. Which of the following crops is **not** grown in Beta area?
 - A. Pyrethrum
 - B. Tea
 - C. Cotton
 - D. Coffee
4. The **main** economic activity practised by the people in Beta area is:-
 - A. livestock keeping
 - B. trading
 - C. crop farming
 - D. transport
5. Which of the following statements is **true** according to Beta area?
 - A. The Eastern part of Beta area has hot and dry climate
 - B. South Western part has black cotton soil
 - C. The area is headed by a district commissioner
 - D. The North Western part of Beta area is a plain land
6. Which means of transport can **best** be used for emergency services in Beta area?
 - A. Road transport
 - B. Human
 - C. Railway transport
 - D. Air transport
7. The main settlement pattern of the inhabitants of Beta area is:-
 - A. scattered
 - B. linear
 - C. nucleated
 - D. sparse
8. Among the Nyamwezi community, the mercenaries hired to provide security were known as:-
 - A. Wanyamphala
 - B. Ntemi
 - C. Rugaruga
 - D. Vatwale
9. Which of the following is the **main** tourists attraction along the Kenyan coast?
 - A. Wildlife
 - B. Beach hotels
 - C. Sandy beaches
 - D. Pre-historic sites
10. How many nominated senators are in Kenya's Senate?
 - A. 47
 - B. 7
 - C. 16
 - D. 12
11. Which of the following statements **best** explains the major problem facing regional trading blocks in Africa?
 - A. Production of similar goods
 - B. Poor transport
 - C. Lack of common currency
 - D. Insecurity
12. Who among the following was the leader of imperial British East Africa company?
 - A. Ludwig Krapf
 - B. William Macknon
 - C. Karl Peters
 - D. Edward Nughey

13. The phrase explaining the dreams a given educational institution is planing to achieve is known as _____
- School routine
 - National Anthem
 - School rules
 - School motto
14. Which chapter in the New constitution defines the fundamental human rights?
- Chapter four
 - Chapter six
 - Chapter eight
 - Chapter eighteen
15. Who among the following leaders were involved in establishment of the African socialism phylosophy?
- Jomo Kenyatta and Paul Ngei
 - Paul Ngei and Tom Mboya
 - Oginga Odinga and Jomo Kenyatta
 - Jomo Kenyatta and Tom Mboya
16. Which of the following is an international public holiday in Kenya?
- Mashujaa day
 - Jamhuri day
 - Madaraka day
 - Labour day
17. The **main** function of the executive arm of National government is:-
- implemnt government policies
 - make laws
 - interpret laws
 - enforce the law
18. Which of the following colours in our National flag shows land of plenty?
- Green
 - White
 - Black
 - White

19. Which of the following statements below explain why the Kenya pipeline was cosntructed in Kenya?
- To reduce road accidents
 - To reduce damage on roads
 - To control theft of oil
 - To enhance creation of employment opportunities
20. What was the **main** form of interaction between the Agikuyu and the Maasai during the pre-colonial period?
- Trade
 - Intermarriage
 - War
 - Sports
21. Which of the following groups comprises of the goods brought by the Arabs during precolonial period?
- Clothes, gold, ivory
 - Slaves, gold, ivory
 - Beads, clothes, swords
 - Ivory, glass, swords

Use the map below to answer questions 22-24

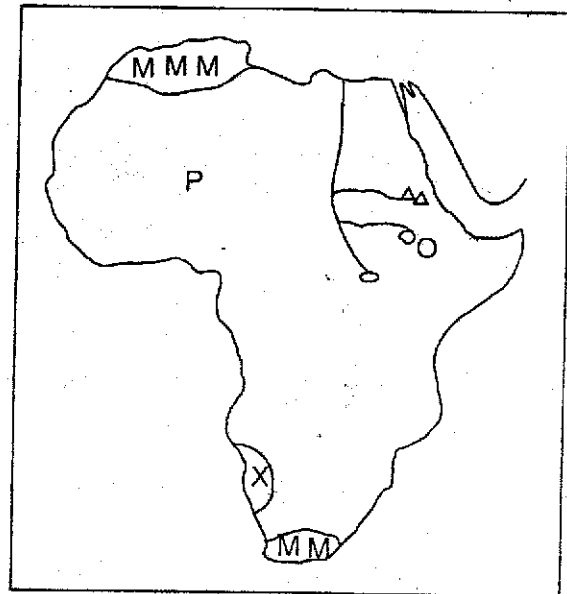

22. In which of the following processes was the lake marked O formed?
- Down warping
 - Faulting and sinking
 - Vulcanicity
 - Lava damming
23. Which of the following factors has resulted to the emergence of desert conditions at the part labelled x?
- Cold adjacent currents
 - Parallel prevailing winds
 - Hot and dry Harmattan winds
 - Warm adjacent currents
24. Which of the following statements is true about the region marked mm?
- The main rain falls during summer
 - They have fold mountains
 - They experience winter conditions during equinoxes
 - They have desert conditions
25. Which is the main economic activity carried out in Fundisa near Malindi?
- Pastoralism
 - Fishing
 - Lumbering
 - Mining
26. Below are traditional weather observation methods. Which one indicated the oncoming of dry spell?
- Hot and humid conditions
 - Blowing of winds during wet seasons
 - Emergence of new moon
 - Trail of ants
27. During weather observation and recording, what time of the day is the minimum temperature taken?
- 7.00am
 - Noon
 - 9.00a.m
 - 3.00pm
28. Which among the following weather instruments should be put in the Stevenson screen?
- Thermometer and barometer
 - Thermometer and hygrometer
 - Barometer and raingauge
 - Raingauge and Thermometer
29. Below are factors influencing climate change. Which one does not affect the climate negatively?
- Deforestation
 - Irrigation farming
 - Agro-forestry
 - Industrialization
30. Which of the following statements best explains why mercury is used in thermometer?
- It is a magnetic metal
 - It is clearly seen
 - It expands and contracts evenly with temperature change
 - It is a rare metal
31. Which of the following is the main problem facing multi-purpose river projects in Africa?
- High rate of evaporation
 - Desertification
 - Misuse of water by surrounding population
 - Siltation of dams
32. Below are soil conservation practices. Which one is not?
- Controlled grazing
 - Ploughing along the contours
 - Mono-cropping
 - Ploughing across the slope

33. The process of carrying out mulching on the bareland left between rows of crops is known as _____
- teraccing
 - Contour farming
 - dry farming
 - strip farming

34. Which among the following communities belief that their ancestors were Mwambu and Sera?
- Luhya
 - Maasai
 - Kalenjin
 - Abagusii

Use the diagram below to answer question 35-36

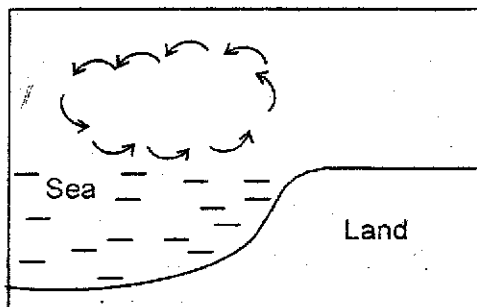

35. The breeze shown above is known as:-
- land breeze
 - day breeze
 - sea breeze
 - night breeze

36. Which among the following places is not likely to experience the above condition?
- Mombasa
 - Kisumu
 - Entebbe
 - Nairobi

37. The human remains found in archaeological sites are commonly known as:-
- skulls
 - excavations
 - artefacts
 - fossils

38. Which of the following statements best explains the reason why periods of evolution are called stone ages?

- The early man lived in stone caves
- Stone was the main raw material for tool making
- Stones were used to build houses
- Most of the history was discovered in inscribed stones

39. Who were the earliest ancestor of the modern man?

- Ramapithecus
- Homo habilis
- Homo erectus
- Zinjathropus boisei

40. Below are pre-historic sites in Eastern Africa. Which combination of sites is found in Ethiopia?

- Laetoli and Ismilia
- Omo valley and Awasa
- Meroe and Nuri
- Lalibela and Boni

41. Peter migrated with his family from his former Kisii farm to a settlement scheme at Mwea Tebere. The form of migration he practised is:-

- Urban to rural migration
- Rural to urban migration
- Urban to urban migration
- Rural to rural migration

Use the diagram below to answer questions 42-43

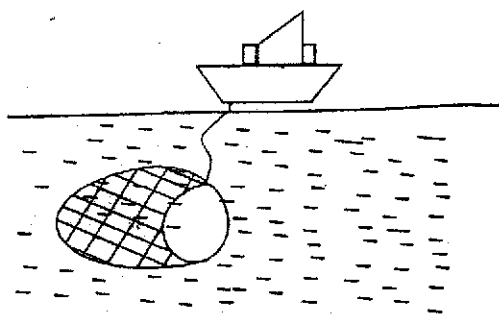

42. The above fishing method is known as:-
- trawling
 - long lining
 - purse seining
 - net drifting
43. Which of the following statements is **not** true about the fishing method above?
- It is the main fishing method in L. Turkana
 - It is used in deep sea fishing
 - It is not encouraged in Lakes
 - It is a large scale fishing method
44. Below are factors affecting population growth. Which one leads to rapid population growth?
- Emigration
 - Epidemics
 - Polygamy
 - Family planning practices
45. Which of the following is **true** about the German population structure?
- It mainly consist of youth
 - Most people live in rural areas
 - There is low living standard
 - Most people are aged.
46. Kenya is made up of _____ constituencies.
- 290
 - 343
 - 47
 - 210
47. Which among the following groups of people below consists of the Kwa speakers **only**?
- Denkyra, Wassa, Kanuri
 - Fanti, Kwahu, Zarma
 - Ashanti, Nupe, Gas
 - Fulani, Fanti, Gurma
48. The **main** reason for marriage in Africa traditional communities was:-
- for companionship
 - for procreation
 - for love
 - for social status
49. Who among the following is **not** a member of the school administration?
- Secretary
 - Prefects
 - Headteacher
 - Senior teacher
50. Which of the following is **not** a role of the school in community development?
- Improving food production
 - Improving the standard of living
 - Giving grants to the community
 - Enabling the learners to respect the law
51. Below are towns in Ghana. Which one is **not** majorly known for Cocoa growing?
- Accra
 - Takoradi
 - Kumasi
 - L. Volta region

52. Below are factors favouring growth of a certain crop;
- (i) Adequate rainfall between 1000 - 1500mm per annum
 - (ii) Well drained volcanic soils
 - (iii) Temperatures below 15°C
- Which of the following crops does well in the above conditions?
- A. Tea
 - B. Coffee
 - C. Pyrethrum
 - D. Sunflower
53. Below are African countries which one is **not** a member of AU (African Union)?
- A. Morocco
 - B. Zimbabwe
 - C. Tanzania
 - D. Libya
54. Which of the following towns is **not** found on cross roads?
- A. Bamako
 - B. Niamey
 - C. Magadi
 - D. Tabora
55. Which of the following was the **main** factor that led to the growth of old Ghana kingdom?
- A. Strong Army
 - B. Powerful clients
 - C. Centralized government
 - D. Trans-saharan trade
56. Which of the following reasons **best** explains why the French signed the Treaty of Bissadugu with Samori Toure?
- A. To create a lasting peace
 - B. To mark the boundaries with his territory
 - C. To get more time for re-organising their army
 - D. They had been defeated
57. Which of the following colonial powers did not take part in Somalia position?
- A. French
 - B. Germans
 - C. Britain
 - D. Italy
58. Which of the following is **not** one of the Islands at the coast of Senegal taken over by France during colonisation?
- A. Goree
 - B. Rufisque
 - C. Dakar
 - D. Accra
59. Kenya gained independence in 1963 with Jomo Kenyatta as:-
- A. Prime minister
 - B. President
 - C. Governor
 - D. Chief minister
60. Which among the following is **not** one of the western Bantus in Kenya?
- A. Luhya
 - B. Abakuria
 - C. Abagusii
 - D. Luo

PART II: RELIGIOUS EDUCATION
SECTION A
CHRISTIAN RELIGIOUS EDUCATION

61. Which statement **best** explains why Adam and Eve were chased away from the garden of Eden?
A. They disobeyed God
B. They listened to the serpent
C. They ate forbidden fruit
D. They were irresponsible
62. The **main** reason for God to call Abraham was to:-
A. test his faith
B. bless all nations
C. bless him only
D. give him descentants
63. Which of the following is the **main** reason why Moses broke the two tablets containing the ten commandments?
A. Many people did not believe in him
B. He was too old
C. He was angered by idol worship
D. He was tempted by the devil
64. Among the following miracles, which one was **not** performed by prophet Elisha?
A. Raising the shunamites son
B. Making axe head float
C. Multiplying flour
D. Raising widows son
65. Who among the following is known as the prophet of doom?
A. Isaiah
B. Hosea
C. Jeremiah
D. Ezekiel
66. Below are the books of the old testament. Which one is **not** classified as a historical book?
A. Joshua
B. Esther
C. Judges
D. Proverbs
67. What **main** lesson do christians learn from the life of Joseph and his brothers in Egypt?
A. Forgiveness
B. Kindness
C. Love
D. Justice
68. Which of the following forms of sexual misuse did Ammon, the son of David **not** commit?
A. Incest
B. Rape
C. Fornication
D. Prostitution
69. Which of the following statements **best** explains why David did **not** kill king Saul even when he had a chance?
A. He had no skills
B. He feared his army
C. He feared killing annointed man of God
D. He had no adequate weapons
70. Which among the tribes of Israel did Zacharia descent from?
A. Judah
B. Benjamin
C. Joseph
D. Levites
71. Who among the following disciples of Jesus was **not** a fisherman before he was called?
A. Peter
B. Andrew
C. James
D. Levi
72. Which of the following **best** explains why Jesus performed few miracles in Nazareth?
A. He was mocked
B. He feared being killed
C. People did not believe in him
D. His disciples discouraged him
73. At the wedding at Cana of Galilee, Jesus changed water to wine to:-
A. show the power of God
B. show love to all people
C. please his mother
D. let people enjoy
74. During the transfiguration of Jesus on Mt. Olives, He was accompanied by the following disciples except:-
A. James
B. John
C. Peter
D. Luke
75. Which among the following presents was **not** given by wisemen to Jesus?
A. Gold
B. Myrr
C. Frankincense
D. Silver
76. The **main** quality required by Jesus from one in order to heal him was:-
A. faith
B. honesty
C. love
D. kindness
77. Which one of the following is **not** a cause of mental suffering?
A. Poverty
B. Loss of loved one
C. Injury
D. Hereditary diseases

78. Which was the **main** occupation of Jesus before He began the Gospel ministry?
- Fishing
 - Tent making
 - Farming
 - Carpentry
79. Among the following, which one was **not** practised by Jesus christ?
- Preaching
 - Healing
 - Forgiving sins
 - Baptising
80. What is the **main** lesson learnt from the story of Jesus and the ten lepers?
- Forgiveness of sins
 - Healing
 - Being thankful
 - Baptising
81. Which statement **best** explains why drug abuse is **mainly** discouraged?
- It is expensive
 - It wastes time
 - It causes lack of discipline
 - It affects people's health
82. Which one of the following concepts of the world led to christians **not** conserving the physical environment?
- Greek philosophy of material things
 - Roman philosophy
 - African concept of universe
 - Law of relationship between spiritual and material things
83. Which among the following parables teaches christians on persistence in prayer?
- Parable of master and servants
 - The parable of the rich young man
 - The parable of lost coin
 - Parable of widow and the judge
84. According to the Akamba story of creation, the parents of the first daughters came from:-
- heaven
 - a rock
 - antihills
 - a river
85. Which among the following events brought people of different ages together in African traditional society?
- Burial ceremonies
 - Marriage ceremonies
 - Initiation ceremonies
 - Ritual on reconciliation
86. Which among the following beliefs is common between African traditional and christianity?
- Belief in ressurection
 - Belief in baptism
 - Life after death
 - Belief in animal sacrifice
87. Below are statements in reference to God. Which one shows the Omnipotence of God?
- God is all powerful
 - God is all knowing
 - God is everywhere
 - God is eternal
88. Which of the following represented the presence of the Holy spirit during the day of pentecost?
- Dove
 - Fire
 - Peter
 - Strong wind
89. James, your friend does not want to help his parents because **he** feels that work makes him dirty. Which is the **best** advice you can give him?
- Pay someone to help him
 - Ask his parents not to give him work
 - Escape from the family
 - Work is God's command
90. The **main** reason why christians should practise charity is because:-
- they should give what they have
 - they should set a good example to others
 - they have more riches than others
 - God will judge them harshly

SECTION B:

ISLAMIC RELIGIOUS EDUCATION

61. Which of the following names of suratul faatiha means "the essence of the Quraan"?
- A. Faatihatul-kitaab.
 - B. Ummul-kitaab.
 - C. Qalbul-qur-aan.
 - D. Suratul-hamd.
62. Which of the following surahs encourages us to give small helps to our neighbors?
- A. Suratul ikhlaas
 - B. Suratul maa-uun
 - C. Suratul-'aṣr
 - D. Suratul fiil
63. In which of the following surahs are the Muslims encouraged to proclaim the favors of Allah upon them always?
- A. Suratul- falaq.
 - B. Suratul-fiil.
 - C. Suratul-dhuhaa.
 - D. Suratul-nnaas.
64. Which of the following is Not a teaching found in suratul-faatiha?
- A. It is the opening chapter of the Quraan.
 - B. We should seek guidance from none other than Allah.
 - C. Allah is the King of the day of judgment.
 - D. Allah is the most merciful.
65. Which of the following statements is true about suratul-kaafiruun?
- A. It is addressing the prophet alone
 - B. It is addressing the Jews alone.
 - C. It is discouraging idol worship with the strongest words possible.
 - D. It is addressing the issue of monotheism alone.
66. The words and actions of the prophet (s.a.w) reported to us by his companions are known as _____
- A. Hadith
 - B. Fiqhi.
 - C. Qur-aan.
 - D. Tawhiid
67. " if you would rely on Allah as the birds do, then He would have given you His sustenance the way He gives it to the birds" This are words of _____
- A. Allah.
 - B. The prophet.
 - C. scholars.
 - D. teachers.
68. Which of the following terms refer to the prayer performed during the drought period?
- A. Swalatul-safar.
 - B. Swalatul-istisqaa.
 - C. Swalatul-khauf
 - D. Swalatul-kusuuf.
69. Which of the following parts of the body is not involved in the performance of Tayammum?
- A. Right hand.
 - B. left hand.
 - C. face.
 - D. legs.
70. In which pillar of swalah are we obliged to send salutations to the prophet (s.a.w)?
- A. Sijdah.
 - B. I-itidaal
 - C. tashahhud.
 - D. Rukuu.
71. Qabliyah and ba'adiyah prayers are performed for the following reasons except one, which one is it?
- A. To spend more time in swalah.
 - B. To compensate for mistakes done in faradh prayers.
 - C. To gain more rewards from Allah.
 - D. To express our love for Allah by communicating to Him.
72. Three of the following things happen during Leylatul qadar, which one does not?
- A. Allah accepts du'a from His devotees.
 - B. Allah forgives a large number of people who repent.
 - C. Angel jibril and others come down to earth.
 - D. The prophet leads others in prayers.
73. Which of the following things never took place during the event of Israa wal miiraaj?
- A. The prophet (s.a.w) was given a tour of Jannah.
 - B. The prophet (s.a.w) was given the five daily prayers.
 - C. The prophet (s.a.w) saw Angel Mikail.
 - D. The prophet (s.a.w) led other prophets in swalah.

74. Which of the following groups of people is not a bonafide recipient of Zakah?
 A. The way farer. B. The orphan.
 C. The reverts. D. The collectors
75. Which of the following is one of the reasons why the Arab leaders refused the message of the prophet (s.a.w)?
 A. It was talking against their gods.
 B. It was praising their gods.
 C. The message was explaining to them importance of their gods.
 D. The message was encouraging them to worship their gods.
76. The prophet (s.a.w) said; "None shall have eaten better than the one who ate from the sweat of his own hands." This hadith teaches us on _____
 A. Generosity. B. Co-operation.
 C. brotherhood. D. Importance of work
77. The prophet (s.a.w) has advised us to slaughter _____ goats for a baby girl during Aqiqah.
 A. One B. Two
 C. Three D. four
78. Why was Abubakar (r.a) given the title of "Assidiq"??
 A. He accepted the religion the first one.
 B. He accepted the story of al-Israa without any doubts.
 C. He accompanied the prophet (s.a.w) during Hijrah.
 D. He was the prophet's (s.a.w) greatest friend.
79. The du'a "Alhamdulillah-Iladhi 'aafaaniy fiima ibtalaaka wa ja'alaniy swahiihan....." Is said when _____
 A. We wake up.
 B. We see a disabled person.
 C. We see something strange.
 D. We enter the toilets.
80. The minimum amount on which Zakah is to be paid is known as _____
 A. Amaanah. B. Nisaab
 C. Hisaab. D. haul.
81. Which of the following acts is a woman in heidh allowed to perform?
 A. Supplication. B. Swalah
 C. Fasting D. Twawaaf
82. Which of the following things is not a role of the masjid?
 A. Offering prayers.
 B. Hosting the refugees.
 C. Hosting of Nikaah
 D. Storage of lost and found items.
83. Which of the following things is common among all the Muslims in the universe?
 A. The muslims names
 B. The muslims clothing
 C. The direction we face when praying
 D. The position we stand while in prayers
84. The year 10 A.P is also referred to as the year of _____ in the Islamic history.
 A. Year of loss.
 B. Year of Israa.
 C. Year of sorrow.
 D. Year of the great Hijrah.
85. Muhammad found a blind woman crossing the road while heading to school, what was the best thing to do?
 A. Pray for her.
 B. Help her to cross the road.
 C. Great her with the Islamic greetings.
 D. Sympathize with the woman.
86. Which of the following is the seventh month of the Islamic calendar?
 A. Rajab. B. Rabiul-awwal.
 C. Swafar. D. Sha'abaan. †
87. Which of the following attributes mean the Most holy?
 A. Al-muumin B. Al-qudus.
 C. Assalaam. D. Al-malik
88. The following acts nullify one's Wudhuu except one, which one is it?
 A. Sleeping. B. sweating.
 C. fainting D. Urinating
89. The battle of Khandaq was given this name because of _____
 A. Being fought in Madinah.
 B. Being fought in Makkah.
 C. The big trench dug around Madinah.
 D. The participation of the prophet (s.a.w)
90. In which of the following battles did the prophet (s.a.w) not participate?
 A. Yamamah.
 B. Uhud.
 C. Badr.
 D. Khandaq.

1. Which of the following numbers is 70666507?
- A. Seven million six hundred and six thousand five hundred and seven
 - B. Seventy million six hundred and six thousand five hundred and seven
 - C. Seventy million six hundred and sixty six thousand five hundred and seven
 - D. Seven million sixty six thousand five hundred and seventy

2. What is the place value of digit 9 in the number 268.0391?
- A. Thousandths
 - B. Tenths
 - C. Hundredths
 - D. Hundreds

3. What is the value of;
- $$\frac{24(12-8)+100 \div 4}{11}?$$
- A. 121
 - B. 96
 - C. 25
 - D. 11

4. How many groups of hundreds does the value of digit 3 represent in the number 853761?
- A. 3000
 - B. 30
 - C. 3
 - D. 300

5. What is the product of the G.C.D and L.C.M of 12, 18 and 24?
- A. 78
 - B. 72
 - C. 432
 - D. 216

6. What is the square root of $22\frac{2}{16}$ in decimal form?
- A. $\frac{3}{4}$
 - B. 4.75
 - C. $4\frac{3}{4}$
 - D. 22.5625

7. Increase 2840 by 40%
- A. 1704
 - B. 2029
 - C. 3976
 - D. 3200

8. What is the value of:
- $$\frac{3}{8}\left(\frac{1}{3} + \frac{3}{4} \div \frac{1}{2}\right) - \frac{3}{8} \times \frac{2}{5}?$$
- A. $2\frac{7}{40}$
 - B. $\frac{33}{40}$
 - C. $1\frac{5}{6}$
 - D. $\frac{43}{80}$

9. What is the difference between the largest and the smallest angles in the figure below?

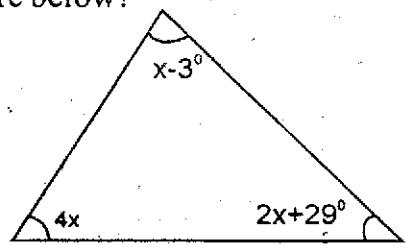

- A. 88°
 - B. 69°
 - C. 22°
 - D. 19°
10. What is the smallest number that can be added to 579521 to make it divisible by 11?
- A. 5
 - B. 3
 - C. 2
 - D. 4
11. Calculate the perimeter of the figure below 3 times

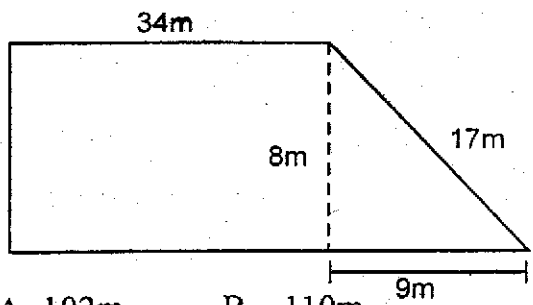

- A. 102m
 - B. 110m
 - C. 306m
 - D. 330m
- EPIC/MATH/STD.8

12. What is the value of:

$$5(8^2 - 6^2) + 48 \div 6 - 11?$$

- A. 137
- B. 140
- C. 148
- D. 121

13. Find the area of the rectangle below

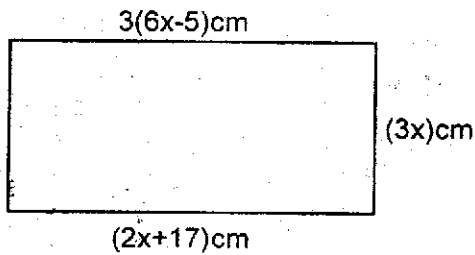

- A. 262cm^2
- B. 126cm^2
- C. 144cm^2
- D. 88cm^2

14. The weights of 6 girls are given below in kilograms 42, 54, 60, 42, 71 and 67. What is the sum of the mean and median?

- A. 336kg
- B. 114kg
- C. 113kg
- D. 263kg

15. Arrange 58% , 0.75 , $\frac{3}{5}$, $\frac{1}{4}$ in ascending order

- A. 58% , 0.75 , $\frac{3}{5}$, $\frac{1}{4}$
- B. $\frac{1}{4}$, $\frac{3}{5}$, 0.75 , 58%
- C. 0.75 , $\frac{3}{5}$, 58% , $\frac{1}{4}$
- D. $\frac{1}{4}$, 58% , $\frac{3}{5}$, 0.75

16. In the figure below, what is the area of the shaded region? Take $(\pi = \frac{22}{7})$

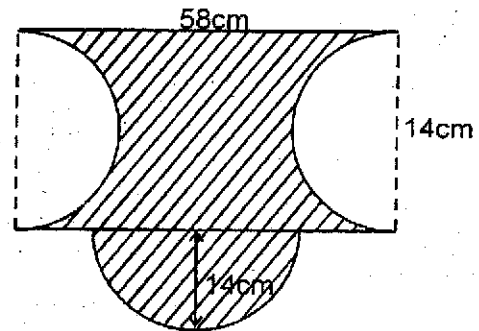

- A. 966cm^2
- B. 812cm^2
- C. 658cm^2
- D. 770cm^2

17. In the figure below XYZ is a straight line, $XY=YW=YZ$. Angle $XYW = 70^\circ$. What is the size of angle YWZ ?

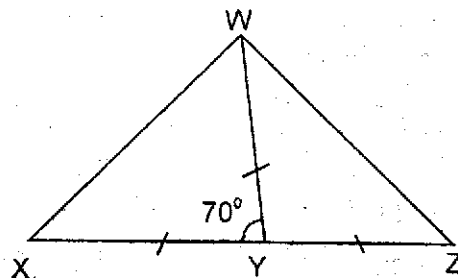

- A. 65°
- B. 35°
- C. 70°
- D. 110°

18. The pie chart below shows how a farmer used a 72 hectare farm. How many hectares did she use on wheat?

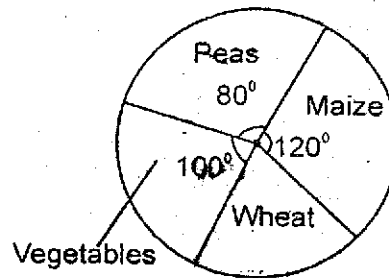

- A. 6ha
- B. 60ha
- C. 12ha
- D. 24ha

19. A mother is four times as old as her son who is x years old, now what will be the sum of their ages in 3 years time?
- A. $5x + 6$
 B. $5x$
 C. $x + 7$
 D. $5x + 3$

20. Kamau drove from Nairobi to Karatina 270km in 3 hours. What was his speed in m/s?
- A. 324m/s
 B. 25m/s
 C. 90m/s
 D. 18m/s

21. Three bells are set to ring at intervals of 12min, 20min and 24min respectively. If they all rung together at 11.45am, what time will they ring together again?
- A. 2.15p.m
 B. 9.45a.m
 C. 1.45p.m
 D. 10.45a.m

22. Solve the following equation

$$\frac{5x-28}{3} = \frac{2x+3}{4}$$

- A. 8
 B. $6\frac{3}{8}$
 C. $\frac{3}{7}$
 D. $8\frac{9}{14}$

23. A metal sheet was used to construct a metallic pipe as shown below. What was the total surface area of the metal sheet used in square centimetres?

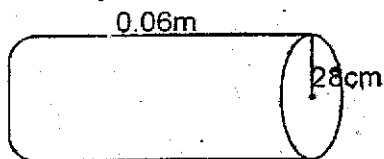

- A. 1056cm^2
 B. 5984cm^2
 C. 3520cm^2
 D. 2464cm^2

24. What is the square of $(1\frac{2}{3})^2$?

- A. $2\frac{7}{9}$
 B. $7\frac{58}{81}$
 C. $3\frac{13}{81}$
 D. $4\frac{3}{5}$

25. A bicycle wheel of radius 21cm turned a distance of 40 revolutions. What was the distance covered in metres?
- A. 5280
 B. 26.4
 C. 2640
 D. 52.8

26. A road is represented by a length of 44cm on a map. What is the actual length of the road in kilometres if the scale used is 1:25000?

- A. 1.1
 B. 110
 C. 11
 D. 1100

27. Write 0.083 as a percentage

- A. 83%
 B. 8.3%
 C. 0.083%
 D. $\frac{83}{1000}\%$

28. Simplify: $\frac{2}{3}(12x+24y) - \frac{1}{5}(20x+5y)$

- A. $4x+17y$
 B. $12x+17y$
 C. $24x-3y$
 D. $4x+15y$

29. John bought the following items from the market;

- $2\frac{1}{2}$ kg of meat at sh.200 per kg
- 3kg of sugar @ sh.110
- 4loaves of bread each at sh.50
- A pair of shoes at sh.1200
- $3\frac{1}{4}$ litres of juice for sh.450

If he paid for the items using two one thousand shilling notes and two five hundred shilling notes, how much did he receive as balance?

- A. sh. 680
- B. sh.2860
- C. sh.320
- D. sh.2580

30. Construct triangle ABC in which AB = 5cm BC=4cm and angle CBA=100°. Draw a circle touching points A, B and C. Find the radius of the circle.

- A. 3.6cm
- B. 1.3cm
- C. 2.6cm
- D. 7.2cm

31. A rectangular piece of land has a perimeter of 350m. Find its area in Ares if its width is 35m

- A. 4.9Ares
- B. 19.6Ares
- C. 3.75Ares
- D. 49Ares

32. A customer paid sh.3510 for a bag of cement after a 25% discount on the marked price. How much was the discount?

- A. sh.1170
- B. sh.877.50
- C. sh.4680
- D. sh.10530

33. In the figure below NO and PQ are parallel lines. While RS is a transversal. Which of the following statements from the diagram is not true?

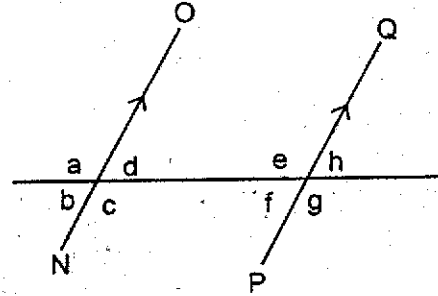

- A. e and h are supplementary angles
- B. a is vertically opposite to angle c
- C. angle f is equal to angle h
- D. d and a are complementary angles

34. Ann, Carol, Sheila and Tina shared some money. Sheila got $\frac{1}{4}$ of the money, Ann got $\frac{1}{3}$ and Tina got $\frac{1}{3}$ of the remainder. What fraction of the money did Carol get?

- A. $\frac{1}{6}$
- B. $\frac{1}{4}$
- C. $\frac{7}{12}$
- D. $\frac{5}{12}$

35. Find the value of the angle marked t

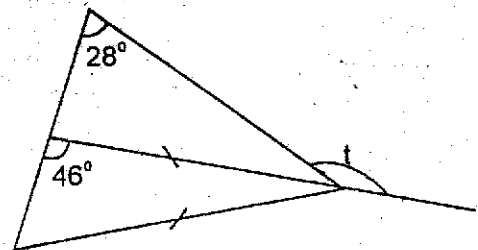

- A. 92°
- B. 162°
- C. 152°
- D. 88°

36. Work out:

t	kg	g
43	294	470
+ 37	220	550

- A. 80t 524kg 20g
- B. 6t 63kg 920g
- C. 80t 515kg 20g
- D. 6t 74kg 20g

37. 65% of the money raised in a school harambee meeting was spend on kitchen construction. If sh.260,000 was spent on the construction, how much money was raised during the harambee?

- A. sh.140 000
- B. sh.169 000
- C. sh.546 000
- D. sh.400 000

38. Find the area of the shaded region in the figure below in cm^2

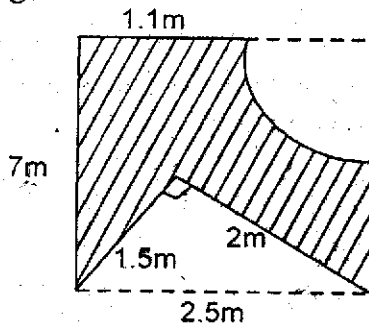

- A. 1292000cm^2
- B. 144600cm^2
- C. 11.34m^2
- D. 16.44m^2

39. Work out: $\frac{1}{8}$ of 40 - $6 \times \frac{1}{12} + \frac{1}{2}$

- A. $\frac{1}{2}$
- B. $3\frac{1}{2}$
- C. 5
- D. $2\frac{1}{3}$

40. The shape below shows a loaf of bread. Find the volume of the shape

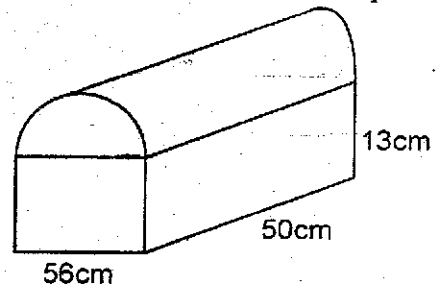

- A. 36400cm^3
- B. 98000cm^3
- C. 4928cm^3
- D. 41328cm^3

41. 16men can do a job in 36 days. How many more men are needed to finish the job in 24days?

- A. 8
- B. 24
- C. 12
- D. 16

42. The table below shows the postal rates for sending money orders;

Value of order sh.	Commission
Not exceeding 1000	sh. 72
1001 - 1500	sh.104
1501-2500	sh. 166
2501 - 5000	sh.257
5001 - 10,000	sh.433
10001 and above	sh.510

Wekesa sent four money orders worth sh.1350, sh.2740, sh.4600 and sh.11050 to four different people respectively. How much commission did he pay to the post office?

- A. sh.871
- B. sh.1037
- C. sh.1128
- D. sh.1051

43. A textbook costs z shillings while a school bag costs thrice the cost of the textbook. What would be the cost of 4 textbooks and 3 school bags?

- A. 4z
- B. 7z
- C. 9z
- D. 13z

44. Sharon bought a dress for sh.860 and sold it at sh.645. What was her percentage loss?

- A. 25%
- B. 75%
- C. 50%
- D. 33.3%

45. Find the value of :

$$\frac{y+12y-6}{9} = 3$$

- A. 4
- B. $2\frac{2}{13}$
- C. $5\frac{1}{4}$
- D. $3\frac{6}{7}$

46. The marked price of a bed was sh.26000. Mutua bought it on hire purchase terms by paying a deposit of sh.14000 and 17 equal monthly instalments of sh.900 each. How much more than the marked price did he pay?

- A. sh.29300
- B. sh.28550
- C. sh.3300
- D. sh.2550

47. The table below shows how a farmer delivered his vegetables in one week. The average number of bags delivered per day was 19 bags

Mon	Tue	Wed	Thur	Fri	Sat	Sun
22	17	13	20	19	—	15

How many bags of vegetables did he deliver on Saturday?

- A. 106
- B. 14
- C. 18
- D. 27

48. Joseph borrowed sh.38000 for a period of two years and 3 months at a simple interest of 12% p.a. How much did he pay altogether?

- A. sh.48260
- B. sh.9120
- C. sh.47120
- D. sh.10260

49. The cost price and selling price of an article are in the ratio 7:9. If the selling price is sh.1080. What is the cost price?

- A. sh.654
- B. sh.840
- C. sh.1240
- D. sh.902

50. Which is the next shape in the pattern below?

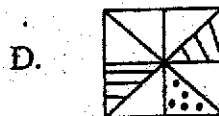
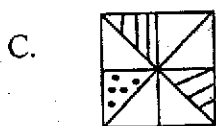
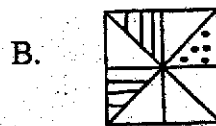
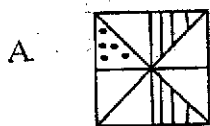
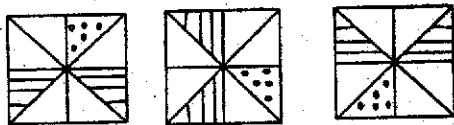

Soma vifungu vifuatavyo. Vina nafasi 1 mpaka 15. Kwa kila nafasi, umepewa majibu manne. Jaza kila pengo kwa jibu lifaalo zaidi.

Wananchi wengi wa Afrika mashariki _____ 1 _____ lugha ya Kiswahili katika mawasiliano _____ 2 _____. Hivi ni kusema kwamba lugha ya Kiswahili _____ 3 _____ nafasi ya pekee katika _____ 4 _____ ya utamaduni, siasa na uchumi.

Wataalamu wengi _____ 5 _____ kwamba kwa kiasi kikubwa lugha ni _____ 6 _____ cha utamaduni. Ukweli huu _____ 7 _____ katika lugha _____ 8 _____, pale ukiizungumza kwa makini utagundua vipengele mbalimbali _____ 9 _____ wasemaji wa lugha hiyo _____ 10 _____ vinajitokeza waziwazi.

- | | | | |
|-----------------------|----------------------|---------------------|---------------------|
| 1. A. walitumia | B. hutumianga | C. huitumia | D. wanapotumia |
| 2. A. wayo | B. zao | C. nayo | D. yao |
| 3. A. kuna | B. ina | C. zina | D. yana |
| 4. A. masuala | B. maswali | C. suala | D. uwanja |
| 5. A. wanapokubali | B. hukubaliana | C. hukabiliana | D. hukaribiana |
| 6. A. maelezo | B. kielezo | C. vielelezo | D. kielelezo |
| 7. A. inajidhihirisha | B. hujithihirisha | C. hujidhihirisha | D. ulijidhihirisha |
| 8. A. yenyewe | B. zenyewe | C. vyenyewe | D. wenyewe |
| 9. A. za utamaduni wa | B. vya utamaduni vya | C. vya utamaduni wa | D. wa utamaduni vya |
| 10. A. ambao | B. ambayo | C. ambazo | D. ambavyo |

Ujenzi wa reli ya _____ 11 _____ kutoka Mombasa hadi Nairobi ukikamilika _____ 12 _____ huduma za uchukuzi wa mizigo na _____ 13 _____ msongomano wa magari barabarani. Abiria watakaosafiri Nairobi kutoka Mombasa watachukua muda wa _____ 14 _____ kwani garimoshi _____ 15 _____ kwa mwendo wa kilomita 120 kwa saa.

- | | | | |
|--------------------|---------------|----------------|----------------|
| 11. A. zamani | B. sasa | C. kisasa | D. kisiasa |
| 12. A. wataboresha | B. utaboresha | C. itaboresha | D. zitaboresha |
| 13. A. kupunguza | B. kuimarisha | C. kuongeza | D. kudumisha |
| 14. A. masaa mbili | B. masaa nne | C. masaa manne | D. saa nne |
| 15. A. litasafiri | B. itasafiri | C. zitasafiri | D. yatasafiri |

Kuanzia nambari 16-30, jibu kulingana na maagizo uliyopewa

16. Maneno haya hufuatana vipi katika kamusi?
(i) shairi (ii) shari
(iii) shwari (iv) sheria
- A. (ii), (i), (iv), (iii)
B. (ii), iv, (iv), (iii)
C. (iii), (i), (ii), (iv)
D. (i), (ii), (iv), (iii)
17. Ukubwa wa sentensi hii ni:
Nguo hii ni ya mtoto wa mzee yule.
A. Kiguo hiki ni cha kitoto cha kizee kile
B. Jiguo hili ni la jitoto la jizee lile
C. Guo hili ni la toto la zee lile
D. Guo hili ni la jitoto la jizee lile
18. Chagua methali isiyo ya kurekebisha jambo mapema.
A. Ngozi ivute ingali maji.
B. Daraja lililokurusha usilibomoe.
C. Kinga ni bora kuliko tiba.
D. Usipoziba ufa utajenga ukuta
19. Kanusha: Kuogopa kwetu kulitufaa.
A. Kutoogopa kwetu hakukutufaa.
B. Kuogopa kwetu hakukutufaa.
C. Kutokuogopa kwetu hakutufai.
D. Kuogopa kwetu hakutufai
20. Chagua sentensi iliyo sahihi kisarufi
A. Mwanafunzi yule hangesoma hangepita
B. Mkulima mwenyewe alituuzia maembe
C. Wakati alipofika alikaribishwa kwa heshima
D. Mahali pale pazuri kumefagiliwa leo
21. Mkeka wake mwembamba umelowa maji sana. Maneno yaliyopigwa mstari ni:-
A. kivumishi, kitenzi
B. kiwakilishi, kivumishi
C. Kivumishi, kielezi
D. kihusishi, kielezi
22. Chagua kundi lenye sauti ghuna pekee
A. b, d, gh, dh B. r, f, y, w
C. t, th, dh, sh D. sh, th, gh, dh
23. "Nitaenda kwangu leo jioni" Musembi alisema. Katika usemi taarifa sentensi hii itakuwa:-
A. Musembi alisema kuwa angeenda kwake leo
B. Musembi alisema kuwa ataenda kwake leo jioni
C. Musembi alisema kuwa ataenda kwake siku hiyo jioni
D. Musembi alisema kuwa angeenda kwake siku hiyo jioni
24. Sentensi ipi ina kiambishi 'ki' cha namna?
A. Alikuwa akicheza nilipomwona
B. Tulivalia kitamaduni siku ya Madaraka
C. Kitambaa hiki kinapendeza zaidi
D. Wakivumilia mateso hayo watafanikiwa
25. Chagua kiwakilishi katika sentensi ifuatayo;
Hicho ndicho kilichomshawishi acheze vizuri na kutuzwa.
A. acheze B. ndicho
C. hicho D. vizuri
26. Udodi ni pambo ambalo huvaliwa mguuni ilhali kikuba huvaliwa:-
A. shingoni B. kichwani
C. kiunoni D. puani
27. 'Piga moyo konde' ni nahau inayomaanisha:-
A. kubahatika B. kushangaa
C. kujuta D. kujitahidi
28. Malipo afoayo mshtakiwa ili:- kuachiliwa kwa muda kesi yake inapoendelea huitwa
A. dhamana B. rufaa
C. faini D. daawa
29. Tumia viambishi sahihi;
Umati wa watu ____ lifika katika mkutano.
A. i B. wa
C. u D. ya
30. Chagua nomino ya dhahania katika sentensi hii: Mshukiwa alikuwa na utulivu mkubwa pale kizimbani.
A. mkubwa B. utulivu
C. kizimbani D. mshukiwa

Bwana Matunda alisomea taaluma ya udaktari sio tu hapa nchini bali pia alienda kwa masomo ya juu nchini Amerika. Baadaye, akaajiriwa kama daktari punde tu aliporejea humu nchini. Kama wasemavyo wahenga, hakuna mchele usiokosa ndume. Alikuwa mlevi. Lakini kwa vile alipata jiko na alitaka kumfurahisha bibi yake, akaamua kuacha ulevi kwa muda. Pia hakutaka kupata aibu ndogo ndogo na lawama nyingi ziletwazo na ugimbi. Hata hivyo, akaamua kutafuta pesa kwa udi na uvumba mbali na mshahara wake ambao haukuwakimu wote kulingana na gharama ya maisha iliyokuwa ghali mno.

Pale hospitalini, hakuwa na mamlaka ya kudhibiti dawa zile. Alifanya kazi ile kama msaidizi wa daktari miongoni ili apate tajriba ya kutibu watu hapa nchini kabla ya kufikia kiwango cha kutawazwa daktari kamili. Alipewa kazi ya kugawia wagonjwa dawa. Aliendesha kazi ile kwa muda mrefu. "Mwenye kovu usitaraji kapoa" wahenga walinena. Hamu ya pesa ilimfanya Bwana Matunda kuingia kwenye mpango ambao haukuenda sawa na maadili ya taaluma yake. Alikuwa akichukua dawa hospitalini na kuziuzia watu usiku. Ilikuwa vigumu kugundua ila hii kwa sababu ati daktari alipomwandikia mgonjwa dawa, Matunda alichukua kiasi fulani na kumpa mgonjwa huyo dawa kidogo. Aliendelea na mtindo huo kwa muda mrefu hususan kwa wagonjwa wasiojua kusoma ambao walikuwa wengi sana nyakati hizo.

Tukishikilia ya wahenga bado kwamba mchovya asali hachovi mara moja, alifanya mpango mwingine ambao ungemletea pesa zaidi na upesi. Akaanza kuchukua vyombo vya hospitali pamoja na dawa na kuanza kuwatibu wagonjwa usiku. Yote haya yalifanyika usiku wakati Chausiku mkewe alikuwa nyumbani na Matunda alidanganya alikuwa zamu ya usiku hospitalini.

Kweli aligonga ndipo kwa sababu njia hiyo ilimletea fulusi kochokocho. Alijiona mwenye pesa, akarudia hulka ya awali. Aliifanya kwa siri ili mkewe na wakuu wake wa kazi wasigundue kuwa alikuwa akipiga mtindi.

Chambilecho wahenga, siku za mwizi ni arubaini. Usiku mmoja wenye giza totoro, Matunda alipokuwa katika kazi yake haramu mtaani, alikuwa na wateja wengi waliopanga foleni ili wahudumiwe. Kila mgonjwa akingoja zamu yake. Mara sauti ya kutisha ilisikika ikisema, "Mikono juu! Ama nyote mtangulie mbele ya haki".

Sauti ile ilikuwa na nguvu ya kuwafanya wote kunywa na kusalimu amri bila hili wala lile. Kurunzi iliyotoa mwangaza ulio wapofusha iliwatia wasiwasi zaidi. Huenda Matunda alikumbuka hadithi ya Saulo alipokuwa njiani kuenda Damaski kuwaua walokole! Kugeuka wakawaona takribani askari polisi kumi na wawili wote tayari kutekeleza wajibu wao kulingana na sheria za nchi. Hakuna aliyedhubutu kukaidi amri.

Wote wakainua mikono, wakalala kifudufudi, wakakaguliwa mwilini, nguoni na nyweleni. Matunda alipatikana na sindano kumi, dawa nyingi, vyombo vingine vya hospitalini na pesa nyingi mfukoni mwake. Wote wakachukuliwa hobelahobela hadi kwenye gari la polisi hadi korokoroni. Keshoye, wakapelekwa mahakamani.

Habari hizo zilienea haraka kama moto kwenye kichaka kikavu. Si redioni, si runingani si gazetini na hata kwenye mitandao. Kesi yao ilichukua siku tatu kuamliwa. Matunda alipatikana na makosa chungu nzima. Hakimuru aliamuru afungwe gereza kwa muda wa miaka sita, kuchapwa viboko ishirini na kufanya kazi ya sulubu. Wengine walitozwa faini ndogondogo na kuachiliwa huru. Kweli mwiba wa kujidunga hauambiwi pole.

31. Bwana Matunda aliajiriwa kama daktari:-
 A. kabla ya kuenda ng'ambo
 B. baada ya kutoka ng'ambo
 C. kabla ya kumuoa Chausiku
 D. akiwa masomoni nchini Amerika
32. Kulingana na kuifungu hiki, methali mwenye kovu usitaraji kapoa ina maana:-
 A. mwenye kovu huwa anapata uchungu daima
 B. mwenye kidonda hakosi kuumwa hata kama kinaonekana kimepoa
 C. mwenye tabia mbovu usidhani ataiacha atairudia hata kama anajifanya ameicha
 D. mwenye kupata jeraha hakosi kupata jeraha tena
33. Badala ya Bwana Matunda kufanya kazi yake vizuri alijihusisha na:-
 A. kuchukua dawa alizokuwa nazo daktari
 B. kuchukua kiasi fulani cha dawa na kuziuzua mle hospitalini
 C. kuiba dawa za wagonjwa hasa wale wasiojua kusoma ambao walikuwa wengi
 D. kuchukua kiasi fulani cha dawa walizopewa wagonjwa na kuziuzua kwa watu usiku
34. Jambo lililomsukuma Matunda kuingilia wizi ni:-
 A. tamaa ya pesa
 B. tamaa ya ulevi
 C. tamaa ya anasa
 D. kumfurahisha mkewe
35. Katika aya ya nne tunaarifiwa Matunda alirudia hulka yake ya awali. Hulka hii ilikuwa:-
 A. kuanza kuiba
 B. kuanza kupigana
 C. kunywa pombe
 D. kupata pesa nyingi
36. Ni sentensi ipi iliyo sahihi kulingana na taarifa hii?
 A. Matunda alipatwa hospitalini na sindano, dawa nyingi na vyombo vingine na pesa nyingi mfukoni
 B. Matunda pamoja na wagonjwa wote walitiwa mbaroni
 C. Matunda aliwahonga askari polisi wasiwapeleke mahakamani
 D. Chausiku alikuwa anajua yale yote mumewa alikuwa akifanya
37. Wateja walijipanga foleni ili wahudumiwe. Huduma ilikuwa:-
 A. kuuziwa pombe
 B. kuuziwa dawa
 C. kupimwa magonjwa
 D. kupewa matibabu
38. Kulingana na taarifa hii, ni kweli kusema:-
 A. ilikuwa sadfa kuwa Matunda walifumaniwa
 B. mke wake ndiye aliyeunda njama ya kuwashika
 C. polisi walikuwa na habari ya biashara ya Matunda
 D. Bwana Matunda alitaka ajulikane zaidi
39. Kilichomfanya Matunda akumbuke hadithi ya Saulo wa Biblia ni:-
 A. mwangaza uliotoka kwenye kurunzi na kuwapofusha
 B. kuona askari kumi na wawili
 C. sauti ya kutisha iliyosikika ikiwaamrisha wainue mikono
 D. kuuawa kwa wale waliojaribu kutoroka
40. Methali inayolingana na taarifa hii ni:
 A. Yaliyopita si ndwele tugange yajayo
 B. Kuishi kwingi ni kuona mengi
 C. Ukiona vyaelea vimeundwa
 D. Tamaa nyingi ilimuua fisi

Soma kisa kifuatacho kisha ujibu maswali 41 – 50

Matokeo ya mtihani wa darasa la nane yalipotangazwa redioni saa sita kamili mchana, Zuhura alikuwa kando ya mto Usi. Ndiyo mwanzo alimalizia kufua marundo ya nguo za wenzake na zake.

Baada ya kumaliza kufua, alizitandaza kwenye majabali ili zikauke aliketi chini ya mti kupumzisha mgongo.

Alikuwa ameketi pale chini ya mti kisha akasikia mchakacho wa miguu ya mtu akihema kama punda aliyebebe kwa mizigo mizito. Akageuka na kutazama ulikotokea mchakacho huo. Alikuwa ndugu yake wa kike mdogo mwenye umri wa miaka mitano.

“Wee Kalekye,” “alitamka Zuhura. “Kwani kuta nini?” Kalekye alijaribu kusema akashindwa. Alikuwa bado anahema hema, miguuni kavaa viatu vya Zuhura. Vilimzidi ukubwa. Ndiyo maana mchakacho ule ukasikika kama wa miguu ya mtu mzima.

Zuhura alivitazama viatu vyake vyeusi alivyokuwa akivitumia shuleni Igumo. Alikuwa na juzi hii tu kavipumzisha hivi viatu. Naye siku hizi akivivaa tu siku ya kwenda kanisani mara moja kwa juma. Sasa alipovitazama viatu vile vizuri aliona kisigino kimoja kimevunjika. Alikereka moyoni. Sasa ataenda na nini kanisani? Fundi wa viatu alienda jongomea mwaka mmoja uliopita na mzee Mwambi tayari alihama. Nani atamshonea kiatu hiki jamani na hakuna fundi mwingine? Lakini Zuhura hakumwonyesha mdogo wake hisia zake za kero.

“Ni nini cha mno?” Zuhura alimwuliza Kalekye. “Matokeo! Matokeo! Alisema Kalekye. “Kweli?” “Redio imetangaza saa hii.” Zuhura alizisomba nguo zake zote zilizokuwa zinaota jua la alasiri na kuzipiga peto ndani ya shuka moja kuukuu. Akamkabidhi Kalekye mpini wa sabuni, sifongo na jiwe la kusugua. Akavichukua viatu vyake alivyokuwa amevivaa Kalekye na kuvibeba mwenyewe mkononi. Wakashika njia ya kuelekea nyumbani. Walimkuta mama tayari ameamdika meza huku sima na majani ya mlenda yakiwa kando kama mboga.

“Kula haraka mwanangu,” Mama alimwambia “Kula haraka kisha upande bodaboda uende shuleni uangalie matokeo.” “Sawa mama,” alijibu Zuhura. Alisali akaanza kula na mdogo wake. Baada ya kumaliza kula, mama yake alimpa noti kongwe ya shilingi hamsini kama nauli ya bodaboda.

Huyoo, Zuhura akaziambua nyayo kuelekea barabara kuu. Alipofika barabarani aliliona kundi kubwa la madereva wa bodaboda. Wote wavulana mabarubaru. Wote walimng’ang’ania mfano wa majibwa yanayogombania mfupa.

Bughudha zao zilikuwa zimefika kilele alipotokea Mzee Fumba Mume wa mke wa marehemu fundi wa viatu.

“Nyinyi wahuni? Mwacheni mwanangu!” Mzee Fumba aliguruma. Naye Simba akiguruma mcheza nani? Vijana wale wote walinywea. Alikuwa anaisukuma baiskeli yake iliyopakwa milia ya manjano kwenye kila mlingoti na mtaimbo na kuacha mapengo ya weusi wake wa awali hapa na pale. Hapakuwa na mlima mkubwa pale uliomlazimu kuisukuma baiskeli, lakini uzee wake umemhini siha na nishati ya kupanda baiskeli hata kwenye vilima vidogo. Ilimbidi aisukume hata kwenye eneo tambarare.

Zuhura alimtazama mume wa mjane wa marehemu fundi wa viatu. Alikuwa amesimama tisti na kufumbata usukani wa baiskeli yake, kichwani taji la mvi lilinadi hekima na busara yake. Alizitazama mvi zake zilizotanda pia kwenye kope, ndevu, masharafa na masharubu. Akaikagua pua ya mzee yule. Uzee ulimboresha. Halinganiki na hivi vinyangarika vivulana vinavyojiita dotikomu. “Unaenda wapi msichana?” Mzee Fumba alimwuliza Zuhura. “Shuleni Igumo” “Panda baiskeli nitakupeleka.” Mzee Fumba aliwageukia madereva wa bodaboda Yena, “Halafu nisikie tena mmemchokoza binti huyu. mtakiona cha mtema kuni.”

Zuhura alikalialia kiti cha abiria kwenye baiskeli ya mzee Fumba huku akielekeza miguu yake kwa upande. Zuhura aliendelea kutafakari matokeo yatakuwa vipi.

Nyumbani mama alikuwa amezama katika mawazo ya kina kirefu. Alifikiria juu ya mustakabali wa bintiye, Zuhura. Tumaini lake la kukwamua yeye na aila yake toka kwenye kinamasi cha umaskini. Lakini je, matokeo hayo yatakuwaje? Isije ikawa habari ya mtungi wa maji ya mtoni kupasukia mlangoni. Mama alisubiri. Saa saba, saa tisa, saa kumi, saa kumi na moja, saa kumi na mbili, saa moja.... Zuhuru hajarudi. Zuhura haonekani. Giza likameza eneo lile, wasiwasi mkubwa ukavaa mamamtu kuhusu mambo ambayo huenda yamemkumba bintiye.

41. Matokeo ya mtihani wa darasa la nane yalipotangazwa Zuhura
- alikuwa nyumbani
 - alikuwa shuleni
 - alikuwa mjini
 - alikuwa mbali na nyumba
42. Kilichosababisha kuhema kwa aliyeleta ujumbe ni
- alikuwa na wasiwasi
 - habari za kuhuzunisha
 - mwendo wa matiti
 - uoga wa kuenda peke yake
43. Mchakacho ulizidi ule wa mtu wa kawaida kwa sababu
- ya viatu vilivyokuwa vikimpwaya miguuni
 - viatu vilikuwa havina visigino
 - viatu havikuwa vyake
 - alitaka kumuudhi Zuhura kwa kuvaa vyatu vyake
44. Zuhura alikereka moyoni. Hii ilitokana na
- kutopatikana kwa bodaboda haraka
 - sima ndogo mama aliyoiandaa
 - habari alizozipata hazikumridhisha
 - kiatu chake kuvunjika kisigino
45. Nguo zilikuwa zinaota jua.. mwandishi alimaanisha
- kukauka kwa nguo
 - kukamuliwa kwa nguo
 - kufua nguo na kuzianua
 - kufua nguo bila sabuni
46. Kalekye ni mdogo wa Zuhuru. Hivyo basi Zuhura limwita
- umbu
 - halati
 - mziwanda
 - mnuna
47. Ni kweli kusema mama yake Zuhura
- alisumbuliwa na madereva wa bodaboda
 - alifahamu alama Zuhura alizozipata
 - alifahamu kuhusu matokeo kuwa shuleni
 - alisaidiwa na mzee Fumba
48. Kulingana na ufahamu huu, nia ya mzee Fumba ilikuwa
- kumpeleka shule
 - kumsaidia Zuhura
 - ni ya kutiliwa shaka
 - ya utu bora
49. Kinachodhihirisha wazi kuwa mzee Fumba hakuwa na nia nzuri ni
- kutoweza kuwa na bodaboda
 - kuwa na mvi zilizotanda kote kichwani
 - kuwazomea madereva wa bodaboda
 - kutofika kwa Zuhura
50. Kichwa mwafaka cha habari hii kinaweza kuwa
- Umdhaniaye ndiye siye
 - Mzee Fumba na Zuhura
 - Zuhura na Kalekye
 - Mama Zuhura na mwanawe

1. Which one of the following waste products is excreted by **all** the excretory organs?
 - A. Excess water
 - B. Urea
 - C. Excess salts
 - D. Carbon-dioxide

2. Which of the following components of the environment produce carbon-dioxide?
 - A. Animals and water
 - B. Soil and air
 - C. Water and soil
 - D. Plants and animals

3. Class four pupils collected the following materials to investigate a certain component of soil:-
 - (i) Soil
 - (ii) Source of heat
 - (iii) Container
 - (iv) Glass slab
 Which component of soil were the pupils investigating?
 - A. Organic matter
 - B. Air
 - C. Water
 - D. Living organisms

4. Mueni accidentally mixed salt and flour. Which of the following procedure can be used to separate the two after adding water?
 - A. Filter - evaporate
 - B. Dissolve - Filter - Evaporate
 - C. Use a magnet - dissolve - evaporate
 - D. Picking - evaporation

5. Which of the following sources of electricity function the same way when in use?
 - A. Dry cells and dynamo
 - B. Solar panel and windmill
 - C. Dynamo and wind driven turbines
 - D. Petrol generator and solar panel

6. The diagram below represents the circulatory system

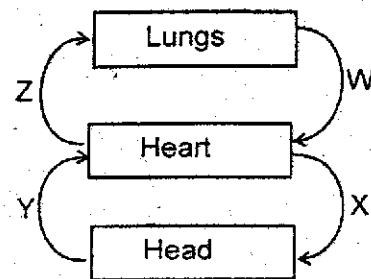

Which blood vessel will carry poisonous blood to the heart if a person is bitten by a poisonous snake?

- A. W
 - B. X
 - C. Z
 - D. Y
7. A class seven pupil had the following signs and symptoms,
 - (i) Pale skin
 - (ii) Pot belly
 - (iii) Wasted muscles
 - (iv) Vomiting diarrhoea
 Which of the following diet was the **most** appropriate for the pupil to feed on?
 - A. Kales, groundnuts, beans
 - B. Liver, kidney, spinach
 - C. Oranges, pawpaw, lemon
 - D. Cashewnuts, green grams, beans

 8. Which of the following **does not** require the force that opposes motion?
 - A. Sharpening a panga
 - B. Closing the window
 - C. Walking up a hill
 - D. Writing on the chalkboard

9. The following are characteristics of some stages of HIV infection:

- (i) Test negative
- (ii) Diarrhoea and weight loss
- (iii) Test positive
- (iv) Can infect others

Which of the above characteristics shows a person who is in the second stage of HIV infection?

- A. (i) and (ii)
- B. (ii) and (iii)
- C. (iii) and (iv)
- D. (i) and (iv)

10. Which of the following is a way of maintaining simple tools that are used in driving out nails?

- A. Sharpening
- B. Storing them in a hole
- C. Cleaning after use
- D. Using them for the right job

11. The diagram below shows a function of a certain part of a plant.

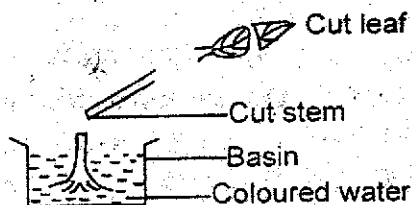

Which function is demonstrated by the activity above?

- A. Transpiration
- B. Absorption
- C. Transportation
- D. Food storage

12. Which of the following statements about sound and light is correct?

- Both _____
- A. can not travel in a bend
 - B. travels in all directions
 - C. can not be reflected
 - D. require a medium of transfer

13. Which one of the following consists of the living components of the environment?

- A. Trees and buildings
- B. Animals and water
- C. Pigweeds and frogs
- D. Water and air

14. The diagram below shows a human tooth



Which of the following is not true about the above tooth? The tooth

- A. has a sharp cutting edge
- B. is used in tearing
- C. has only one root
- D. is part of the deciduous set

15. Which one of the following percentage of the composition of air is not needed by living things?

- A. 78%
- B. 21%
- C. 0.03%
- D. 0.97%

16. Which one of the following farm animals is correctly matched with its animal produce?

- A. Sheep - Wool and milk
- B. Goats - Mutton and milk
- C. Cattle - Beef and mohair
- D. Poultry - Eggs and wool

17. Which one of the following statements is **correct** about reproduction in human beings?
- The disc shaped organ helps in exchange of gases
 - The mass of cells is known as the zygote
 - Implantation takes place in the oviduct
 - The ambilical cord protects the foetus from shock

18. The table below shows the amount of water that was retained by different soils

Soil sample	W	Z	K
Water retained	30cm ³	15cm ³	10cm ³

Which soil is represented by the set up below?

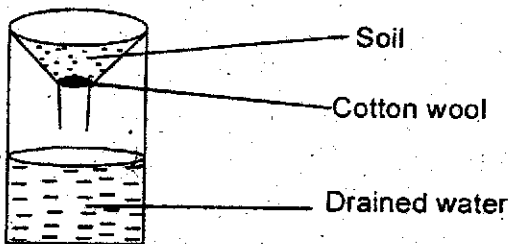

- W
 - Z
 - K
 - W and K
19. Which one of the following statement is **correct** about the child's immunisation schedule?
- Tuberculosis vaccine is given on the left upper arm
 - The last DPT is given on the 9th month
 - The first polio vaccine is given at the 6th week
 - DPT vaccine is given on the thigh

20. The following are safety measures about lightning. Which one is **not**?
- Fitting houses with lightning arrestors
 - Avoid touching switches with wet hands
 - Avoid sheltering under tall trees
 - Do not lean on the walls when it is raining

21. The following are methods of preserving food;
- Proper storage
 - Use of honey
 - Use of low temperature
 - Salting

Which of the above methods of preserving food are both modern and traditional?

- (i) and (iii)
- (iii) and (iv)
- (ii) and (iv)
- (i) only

22. The diagram below represents a food chain;
- Nectar → butterfly → Chameleon → hawks
- Which one of the following will **not** happen, if all chamelions are killed?
- Hawks will decrease
 - Nectar will increase
 - Butterflies will increase
 - Nectar will decrease

23. A Science teacher came to class with the following materials;

- Candle
- String
- Cardboards
- Matchbox

Which of the following activities was the teacher demonstrating?

- Natural sources of light
- Light travels in all directions
- Light travels in a straight line
- Reflection of light

24. Which one of the following statements about gases is **not** correct? Gases
- do not have a definite size
 - are poor conductors of heat
 - expand most when heated
 - are good conductors of heat
25. During a Science lesson, four pupils collected the following materials to construct different weather instruments;
- Omondi - metal sheets, pieces of wood, biro pen cap
- Mathenge - a small plastic bottle, big plastic bottle, manila paper, cellotape
- Wanjuki - A glass bottle, basin, inner tube of a biro pen, manilla paper
- Esther - A glass bottle, inner tube of a biro pen, manilla paper, cellotape
- Which pupil was to make an air thermometer?
- Mathenge
 - Wanjuki
 - Esther
 - Omondi
26. Which one of the following methods of conserving water helps in reducing water pollution?
- Turning off the taps when not in use
 - Harvesting rain water
 - Spreading crop remains on the base of growing crops
 - Boiling water and cooling the steam
27. The following are modes of movement in small animals **except**:-
- stinging
 - hopping
 - crawling
 - walking

28. Plants that grow in wet areas have hairs on the upper surface, the function of the hairs is to
- reflect heat and light
 - trap moisture from the hair
 - keep the stomata open
 - reduce the rate of transpiration
29. The diagram below shows a tank that contains water with holes at different positions;

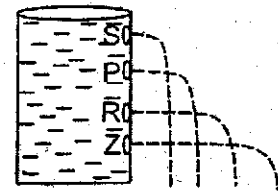

- Which one of the following can make hole P to jet out water the shortest distance?
- Putting a lid at the top of the tank
 - Decreasing the diameter of the hole
 - Putting the tank on a higher ground
 - Closing the hole at the bottom
30. Which one of the following animal feeds helps the animals in growth and repairing worn out tissues?
- Lucern and salt licks
 - Salt licks and sunflower seeds
 - Wheat bran and napier grass
 - Glycine and lucern
31. Which one of the following states of matter are **correctly** grouped according to their characteristics?
- | <u>Definite volume</u> | <u>Definite mass</u> |
|------------------------|----------------------|
| A. Water vapour | Stone |
| B. Cooking oil | Saw dust |
| C. Steam | Tooth paste |
| D. Nitrogen | Oxygen |

32. Which of the following consists of foods that build and strengthen our immunity?
- Pawpaw, mango, watermelon
 - Kales, beans, oats
 - Mutton, pork, beef
 - Milk, maize, millet

33. Which of the following effects of drug abuse are **correctly** classified into social and health effects?

<u>Health effects</u>	<u>Social effects</u>
A. Truancy	Rape
B. Poor health of the unborn	Death
C. Death	Loss of memory
D. Poor concentration	Marital conflicts

34. The diagram below shows movement of heat in gases;

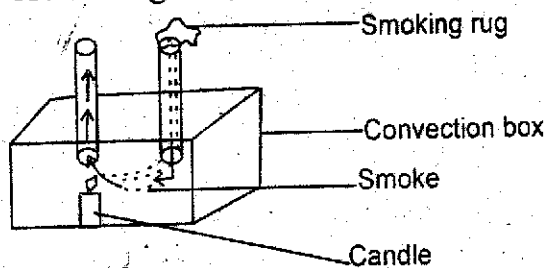

What is the function of the smoke?

- To increase the speed of air movement
 - To make the air visible
 - To warm the air
 - Reduce the rate of burning the candle
35. Which one of the following is the **best** natural way of lighting a house?
- Using fireflies
 - Using candles
 - Opening windows
 - Using fire

36. The following are characteristics of weeds;

- Thorns on leaves and stem
- Fleshy stem that grows in the ground
- Purple flowers
- Fibrous roots

Which characteristics describes a wandering jew?

- (i) and (iv)
- (i) and (ii)
- (i) and (iii)
- (iii) and (iv)

37. Which one of the following factors **does not** affect the rate at which a liquid evaporates?

- Moving air
- Amount of the liquid
- Temperature
- Surface area

38. The following are characteristics of clouds;

- High in the sky
- Rounded masses
- Dark grey
- Have an irregular shape

Which characteristics would make a good scientist put on light clothes?

- (iii) and (iv)
- (i) only
- (ii) only
- (i) and (ii)

39. Which one of the following processes changes ice cubes into water vapour?

- Melting - freezing
- Melting - evaporation
- Freezing - condensation
- Condensation - freezing

40. Purity saw an animal that had scales and laid eggs that were fertilised. The animal is likely to be a
- lizard
 - frog
 - fish
 - spiny ant eater
41. Which of the following materials can **not** help in forming a shadow?
- Piece of wood
 - Stones
 - Glass
 - Tank
42. When modelling the solar system all the following materials can be used. Which one can **not**?
- Thorns
 - Clay soil
 - Softboard
 - Rubberband
43. Which of the following internal livestock parasites attack the intestines **only**?
- Hookworms
 - Liverflukes
 - Roundworms
 - Tapeworms
44. Which one of the following levers function the same way when they are in use?
- Wheelbarrow and spade
 - Crowbar and clawhammer
 - Spade and crowbar
 - Wheelbarrow and claw hammer

45. The following are ways of controlling soil erosion;

- Mulching
- Planting cover crops
- Building porous dams
- Terracing

Which of the above methods can control soil erosion where soil is carried in thin uniform layers?

- (i)
- (iv)
- (ii)
- (iii)

46. The diagram below represents a beam balance

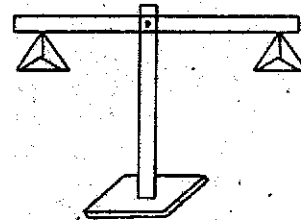

Which of the following materials is **not** needed in making the above instrument?

- Plunk of wood
- Nails
- Strings
- Tins of different materials

47. The following are descriptions of some methods of grazing;

- (i) *animals move freely*
- (ii) *Easy to collect manure*
- (iii) *Controls both internal and external parasites*
- (iv) *Expensive to start and maintain*

Which descriptions refer to a method that can be used in areas where land is limited?

- A. (i) and (ii)
- B. (ii) and (iii)
- C. (ii) and (iv)
- D. (iii) and (iv)

48. The diagram below represents a certain property of light;

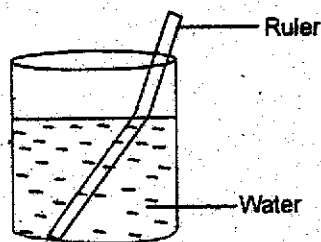

Which of the following activities does not use the principle of the above experiment?

- A. Formation of images
- B. A swimming pool appearing shallow
- C. A coin in water appearing raised
- D. A pool of water appearing on a tarmac road

49. The following are signs of a certain water borne disease

- (i) *Violent diarrhoea*
- (ii) *Vomiting*
- (iii) *Dehydration*

The disease can best be prevented by

- A. Avoiding overcrowded places
- B. covering pit latrines
- C. taking a balanced diet
- D. draining stagnant water

50. Two pupils were balancing on a see saw as shown below

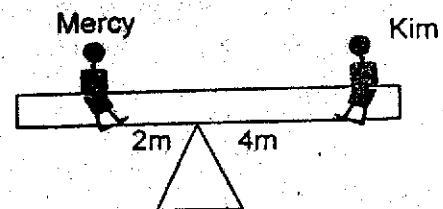

It is true to say that:-

- A. Kim is twice heavier than Mercy
- B. both pupils are of the same weight
- C. Mercy is twice heavier than Kim
- D. the see saw is not balancing

Read the passage below. It contains blank spaces numbered 1 - 15. For each blank space, choose the BEST alternative from the choices given.

The increasing rate of crimes is a problem that is affecting not only the developing countries 1 those that 2 developed. These crimes range 3 theft, prostitution and killing. Hijacking and kidnapping are 4 sophisticated crimes. It is evident that these problems are rampant in the urban areas 5 to high population. Many people 6 to the town centres to search for job opportunities 7 are very rare nowadays.

Generally, crimes have affected all nations of the world in one way or 8, for instance, the economies of countries 9 strained because large sums of money has to be allocated to feed and 10 prisoners, still, as 11 to supplement the work of courts many people have 12 what they proudly call 'mob justice'. This simply means impliciting punishment on the spot to the culprit or 13 and it involves serious beating, 14 or mutilating the culprits body parts. 15 it is not a recommended way of handling culprits, most people find it hard to avoid.

- | | | | | |
|-----|----------------|-----------------|-----------------|-----------------|
| 1. | A. even though | B. but also | C. nevertheless | D. more so |
| 2. | A. has already | B. are already | C. was already | D. have already |
| 3. | A. from | B. off | C. between | D. to |
| 4. | A. most | B. more | C. many | D. majority |
| 5. | A. because | B. as a result | C. due | D. drawn |
| 6. | A. reside | B. live | C. stay | D. go |
| 7. | A. when | B. where | C. which | D. whose |
| 8. | A. another | B. other | C. any other | D. either |
| 9. | A. has | B. is | C. have | D. were |
| 10. | A. accommodate | B. accomodate | C. accomondate | D. acommodate |
| 11. | A. when | B. so | C. how | D. if |
| 12. | A. stepped up | B. stepped down | C. stepped from | D. stepped over |
| 13. | A. innocent | B. prisoner | C. thief | D. suspect |
| 14. | A. leanching | B. lynchieng | C. lynching | D. linching |
| 15. | A. So that | B. Though | C. Eventually | D. resulting |

In questions 16 to 17 choose the sentence that means as the given one.

16. As soon as she woke up the baby began to cry.
- A. The baby had not woken up when she started crying.
 - B. The baby cried as she was waking up.
 - C. The baby started crying immediately after waking up.
 - D. No sooner had the baby started crying than she woke up.
17. Sam is as active as any other pupil in the class.
- A. Other pupils in the class are not as active as Sam.
 - B. Other pupils in the class but not Sam are active.
 - C. Neither Sam nor the other pupils in the class are active.
 - D. Sam is just as active like the other pupils in the class.

For question 18 and 19 select the best choice to fill in the blank spaces

18. Hardly had the bus left _____
- A. that it collided with an incoming car.
 - B. than it collided with an oncoming car.
 - C. when it collided with an oncoming car.
 - D. and it collided with an oncoming car.
19. She bought _____ suitcase.
- A. an inexpensive, ugly, big
 - B. a big, inexpensive, ugly
 - C. an ugly, big, inexpensive
 - D. an inexpensive, big, ugly

For question 20, change the given sentence into reported speech

20. "We will visit the media reporters today," the teacher said.
- A. The teacher said that they would visit the media reporters today.
 - B. The teacher said that they will visit the media reporters that day.
 - C. The teacher said that we will visit the media reporters today.
 - D. The teacher said that they would visit the media reporters that day.

Choose the opposite of the underlined words in questions 21-22

21. After the investigation, the suspect was found guilty of the offence.
- A. responsible
 - B. sober
 - C. innocent
 - D. futile
22. It was challenging for the team to accept defeat.
- A. winning
 - B. victory
 - C. losing
 - D. mockery

For questions 23-24, choose the best phrasal verbs to replace the underlined words

23. It was difficult for the two pupils to become friends again after their break up.
- A. make up
 - B. make for
 - C. make off
 - D. make out
24. It took long for the post election violence victims to recover from the calamity.
- A. get through
 - B. get together
 - C. get away
 - D. get over

For question 25, choose the best arrangement of the given phrases to make a sensible paragraph

25. (i) this will refresh them so that they are able to concentrate better during studies
- (ii) and how the activities will affect their performance in class
- (iii) it is important for pupils to have some time to rest and relax
- (iv) However they need to know which activities to engage in during this leisure time
- (v) they should also know how much time to spend on the leisure.
- A. (iii), (ii), (i), (v), (iv)
 - B. (iv), (i), (iii), (ii), (v)
 - C. (iii), (i), (iv), (v), (ii)
 - D. (v), (ii), (i), (iv), (iii)

Read the passage below and answer questions 26 - 38.

It is said that every dog has its own day, and my day had come. I was to represent my school in a county level athletics competition that we had been longing for. I was now a celebrity in my county, having taken the runners-up position and won severally. Now, I was sure that I would win with flying colours, as I had trained hard everyday from five o'clock in the morning. I ran for at least ten kilometers daily. My parents had been a great inspiration to me because they had always encouraged me. Although, they always told me that nothing good comes easily and I had to work hard in order to succeed.

"I will not let them down," I said to myself. I had practiced enough that morning. At around nine o'clock that morning, the whole field was filled up with people, both participants and spectators. A voice rang over loudspeaker instructing the participants to go to their respective areas. Personally I was representing my school in the marathon race, which most people feared for it was not easy to finish. When I heard that voice, my heart pounded so hard that I was afraid. I definitely knew that spectators cheered as the marathon competitors moved to the starting point. The voices I heard from the spectators and especially my supporters assured me that I will make it.

The winner of the race would represent the nation in the international marathon abroad. I was determined to be the winner though I never knew how competitive my competitors were. I looked forward to travelling abroad after being declared the winner. Now, the crowds in the stands went wild with a thunderous applause, as we got into our positions. Soon, the gun went off and the race was on. Already, I had my strategy well planned. It was a three piece plan. I had, to start fast and make everybody tire themselves out. Secondly, I would slow down to make in breath and prepare for the final lap, the home stretch. I planned to sprint energetically to finish in the first position. I adhered to my plan.

Running as fast as a deer, other competitors panted and puffed as they tried to keep up with me as soon as the race began. At the middle of race, I slowed down something that made them think that I was worn out. They shot past me and to their surprise, I was not putting any effort to overcome them. However, in the final lap, I leaped forward with the renewed energy. I went past the tired athletes with a high speed. Soon, I broke the finishing tape with my arms stretched out. It was clear that I was the winner. Fans and spectators shouted with joy all over the stadium. I was declared the best runner of the year. My dreams had all come true.

26. The writer had been highly celebrated because:-

- A. his parents had always encouraged him.
- B. he had already won several times.
- C. he was chosen to represent his school in the race.
- D. he was the only one capable of participating in the race.

27. The writer was sure of winning, probably because:-

- A. of the great inspiration from his parents scared him.
- B. he had been sure of winning.
- C. he had been training hard every morning.
- D. he never wanted to let down his colleagues.

28. The words longing for as used in the passage mean:-

- A. to anticipate.
- B. to lose patience.
- C. to become conscious.
- D. to become excited.

29. The marathon race was feared by many people because:-

- A. it was not a popular game.
- B. only a few people took part in it.
- C. it was hard to finish the race.
- D. it was highly competitive.

30. The people who flocked the field:-
 A. had only come to be spectators.
 B. had come to watch while others were to take part in the race.
 C. were the participants of the race only.
 D. were attracted by the voice that sprang over the loudspeaker.
31. The writer was optimistic of winning as he went to the starting point because:-
 A. he had always been winning in the past
 B. his parents had told him to work hard to achieve his goal.
 C. he knew the other participants will not be able to finish the race
 D. the voices he heard from his spectating supporters were encouraging
32. The crowds in the stands went wild. This means that
 A. they broke into a fight.
 B. they demanded for change.
 C. they cheered vigorously.
 D. they uttered mocking words.
33. Though the writer was determined to win the race:-
 A. he never expected to travel abroad.
 B. he never knew how competitive his competitors were.
 C. he was not ready to participate in the race abroad.
 D. he knew that his competitors were better than him.
34. The writer's three piece plan included the following except:-
 A. to run at a fast speed throughout the race.
 B. to start at a fast motion to make the others exhausted.
 C. to run slowly after a while to take in breath and relax.
 D. to sprint energetically in the final lap.
35. As soon as the race began, the other competitors panted hard because:-
 A. they had not prepared themselves adequately.
 B. the writer seemed to lag behind.
 C. they were trying to keep with the writer's pace.
 D. it was not hard for them to keep with the writer's speed.
36. When the other competitors ran past the writer:-
 A. they were surprised at how unprepared the writer was.
 B. they were only trying to keep with his pace.
 C. he put up a lot of effort to defeat them immediately
 D. they were amazed that he was not willing to overcome them
37. The word 'worn out' are used in the passage to mean:-
 A. amazed
 B. fatigued
 C. useless
 D. dismayed.
38. From the passage, it is not true to say that:-
 A. the writer realised his dream.
 B. the writer was unable to overcome his competitors.
 C. the crowd was overjoyed with the writer's victory.
 D. the writer had planned well for the race.

Read the passage below and answer questions 39 - 50.

Everyone is becoming concerned about the rapid increase in the number of children being born every year. In our nation almost four hundred thousand children are born annually. In the whole nation most people are under the age of fifteen years. This high population makes it hard to provide every child with the essential needs such as good health care, clothes, shelters, food and education.

Every ten years, our government organizes a population census, its aim being to know the number of people in the country, their age, sex, level of education and other essential information. This helps the government to plan for its citizens. Though population was not as high as it is today, population has increased at an alarming rate. The few resources that are available in the country and especially, the rural areas, cannot support the people. As a result most people find it necessary to move to the towns to search for jobs, which are rare and not readily available.

For many years, agriculture has remained the backbone of our country's economy upto date. People should be encouraged to depend on agriculture still as it is the most dependable source of income in our nation. Most young people do not like doing farming but like doing white collar jobs, which are very few and scarce. Instead of moving to towns, people should concentrate on their farms in the rural areas, the government should also be willing to provide water, financial support and fertilizers to the citizens so as to nurture their farming. Roads in the rural areas should also be constructed as well as putting up electricity. Most rural areas do not have adequate water and electricity which makes it hard to do various businesses. Though Kenya has land as a resource, it is unpleasing to know that most parts in our nation always face the problem of food shortage every year. This detars any developments in the area. So, it is better for many people to go back to the rural areas and do other projects other than congesting themselves in towns as this leads to increase in crimes such as theft, or robbery, prostitution, lack of adequate housing and other social problems.

39. The writer, in the first sentence, says that:-

- A. though many children are born every year, on one is concerned.
- B. only a few children are born every year
- C. the rapid increase in number of children born every year has become everyone's concern.
- D. the number of children born every year has not increased.

40. From the passage, the number of children born every year is:-

- A. almost 400,000
- B. more than 400,000
- C. not less than 400,000
- D. approximately 400,000

41. Which one is as a result of high population according to the passage?

- A. Many children being below the age of fifteen years.
- B. Inability to provide essential necessities to children.
- C. High standards of living.
- D. Making it necessary to conduct census.

42. Our government knows the number of people in the nation by

- A. carrying out a national census.
- B. taking all children to school.
- C. looking at their level of education.
- D. providing them with food.

43. The writer says that in the past:-
A. population was high as it is today.
B. essential needs were rapidly catered for
C. the government never planned for its people.
D. population was not as high as it is today.
44. Which statement is not correct?
A. Today, most people move to towns than in the past.
B. Jobs have become scarce today.
C. Many people who move to towns get employed easily.
D. The available resources cannot sustain all people.
45. The phrase 'agriculture has remained the backbone of our country's economy' implies that :-
A. many people do not like agriculture.
B. many people rely on agriculture.
C. agriculture has limited benefits
D. everyone in the country does agriculture
46. The writer says that young people:-
A. like doing farming in the rural areas.
B. are born and brought up in towns.
C. embrace farming as well as doing white collar jobs.
D. like being employed than doing farming.
47. According to the passage, it is not easy to do business in the rural areas because:-
A. they lack the necessary necessities such as electricity and water.
B. most people live in the urban areas.
C. they are not good sites for doing business.
D. people get discouraged easily.
48. The problem of food shortage in most parts of our country:-
A. causes fast development in the given areas.
B. is attributed to lack of land.
C. leads to lack of development in the areas.
D. is not common every year.
49. The writer is advising people to:-
A. move to towns as rural areas are unproductive.
B. ignore agriculture and do white collar jobs.
C. go and do meaningful projects in the rural areas.
D. commit crimes to earn income.
50. The writer has listed down the following ways of improving agriculture in the rural areas. Which is not?
A. Providing financial support to the farmers.
B. Becoming congested in the towns.
C. Constructing roads in rural areas.
D. Providing water and electricity in the rural areas.

Lined writing area with horizontal lines.

**EPIC EXAM 2016
STANDARD EIGHT
MARKING SCHEME**

**EPIC
EXAMS 004**

ENGLISH	KISWAHILI	MATHS	SCIENCE	SOCIAL STUDIES	
1. B	1. C	1. C	1. A	1. C	51. D
2. D	2. D	2. A	2. D	2. B	52. C
3. A	3. B	3. D	3. C	3. A	53. A
4. B	4. A	4. B	4. B	4. C	54. C
5. C	5. B	5. C	5. C	5. D	55. C
6. D	6. D	6. B	6. D	6. A	56. C
7. C	7. C	7. C	7. D	7. C	57. B
8. A	8. A	8. D	8. B	8. C	58. D
9. C	9. C	9. B	9. C	9. C	59. A
10. B	10. D	10. B	10. D	10. C	60. D
11. D	11. C	11. C	11. C	11. A	C.R.E
12. A	12. B	12. A	12. B	12. C	I.R.E
13. D	13. A	13. B	13. C	13. D	61. A
14. C	14. D	14. C	14. D	14. A	62. B
15. B	15. A	15. D	15. D	15. B	63. C
16. C	16. D	16. A	16. B	16. D	64. D
17. D	17. C	17. B	17. B	17. A	65. B
18. B	18. B	18. C	18. B	18. A	66. D
19. A	19. B	19. A	19. D	19. B	67. A
20. D	20. A	20. B	20. B	20. A	68. D
21. C	21. C	21. C	21. D	21. C	69. C
22. B	22. A	22. D	22. B	22. D	70. A
23. A	23. D	23. A	23. C	23. A	71. D
24. D	24. D	24. B	24. B	24. C	72. C
25. C	25. C	25. D	25. B	25. D	73. A
26. B	26. B	26. C	26. B	26. C	74. D
27. C	27. D	27. B	27. A	27. A	75. D
28. A	28. A	28. D	28. C	28. B	76. A
29. C	29. C	29. C	29. B	29. C	77. C
30. B	30. B	30. A	30. D	30. C	78. D
31. D	31. B	31. D	31. B	31. D	79. D
32. C	32. C	32. B	32. A	32. B	80. C
33. B	33. D	33. D	33. D	33. C	81. D
34. A	34. A	34. A	34. B	34. A	82. A
35. C	35. C	35. B	35. C	35. C	83. D
36. D	36. B	36. C	36. D	36. C	84. B
37. B	37. D	37. D	37. B	37. D	85. B
38. A	38. C	38. B	38. D	38. B	86. C
39. C	39. A	39. C	39. B	39. B	87. A
40. D	40. D	40. B	40. A	40. B	88. B
41. B	41. D	41. A	41. C	41. D	89. D
42. A	42. C	42. C	42. D	42. A	90. A
43. D	43. A	43. D	43. A	43. A	
44. C	44. D	44. A	44. B	44. C	
45. B	45. A	45. B	45. C	45. D	
46. D	46. D	46. C	46. D	46. A	
47. A	47. C	47. D	47. C	47. C	
48. C	48. C	48. A	48. A	48. B	
49. C	49. D	49. A	49. B	49. A	
50. B	50. A	50. A	50. C	50. C	

NB: Teachers are requested to scrutinize this marking scheme before use, it is worth.