

- Write eight million six hundred and forty eight thousand and nine hundredths written in figures.
A. 8648900
B. 8648000.09
C. 8648000.009
D. 8648000.900
- By what number would you multiply the digit in the place value of thousandths to make it a whole number in the number 48.3957?
A. 5
B. 500
C. 1000
D. 100
- Round off 478 to the nearest thousands.
A. 1000
B. 500
C. 400
D. 0
- The perimeter of a rectangle is 62cm. Its length is 24cm. If the diagonal of the rectangle is 5xcm, calculate the value of x
A. 5cm
B. 25cm
C. 14cm
D. 36cm

- Calculate the area of the figure below.

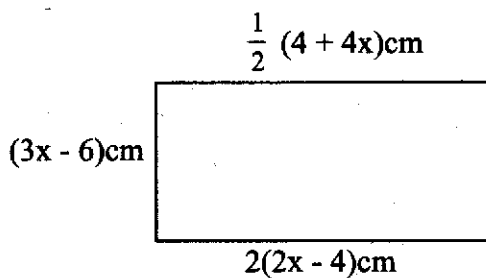

- 96cm^2
- 120cm^2
- 108cm^2
- 144cm^2

- A car travelled 54km in 45 minutes. What was its speed in m/s?
A. 72m/s
B. 18m/s
C. 25m/s
D. 20m/s
- Solve the value of x in the equation below.

$$1\frac{1}{2} + \frac{x}{3} = x + 1$$

- $\frac{3}{4}$
- 6
- 12
- $1\frac{7}{8}$

- What is the next fraction in the sequence below?
1, 3, 3, 9, 27, _____
A. 81
B. 243
C. 54
D. 143

- The figure below represents a trough used by Mr. Ogeto's cows to drink water.

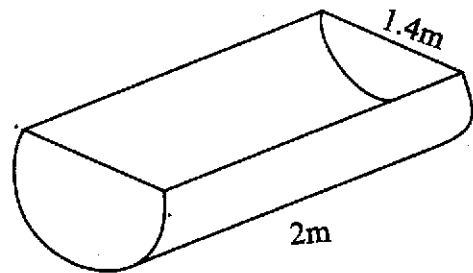

Calculate the total surface area of the metal sheet used to make the trough?

- 7.7m^2
- 7.48m^2
- 5.94m^2
- 10.56m^2

10. Joan and Jane shared some money in the ratio of 2:5 respectively. If Joan received sh. 135 less than Jane, how much money were they sharing altogether?
- A. sh. 315
 B. sh. 675
 C. sh. 260
 D. sh. 225

11. A truck left Nairobi at 2045 hours on Monday and arrived at Kampala on Tuesday at 4.30am. How much time did the journey take?
- A. 16 hours 15 minutes.
 B. 7 hours 45 minutes.
 C. 6 hours 15 minutes.
 D. 19 hours 45 minutes.

12. Calculate the area of the figure drawn below given that O is the centre of the semi circle.

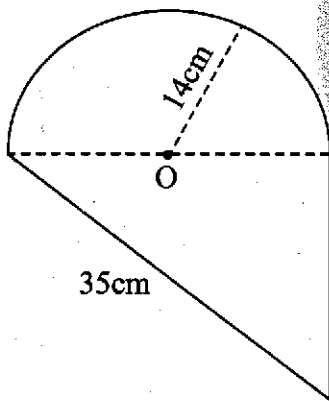

- A. 602cm^2
 B. 910cm^2
 C. 448cm^2
 D. 616cm^2
13. A container whose capacity is 450000ml was three fifth full of milk. The milk was then packed into 15dl packets. How many packets were obtained?
- A. 180
 B. 270
 C. 30
 D. 300

14. The total surface area of an open cube is 320cm^2 . Calculate its volume.
- A. 512cm^2
 B. 320cm^3
 C. 640cm^3
 D. 512cm^3

15. The figure below represents a church window. Line $AB = ED = 18\text{cm}$, $FC = 12\text{cm}$ and line $BC = CD = 4\text{cm}$. $AF = EF = 5\text{cm}$

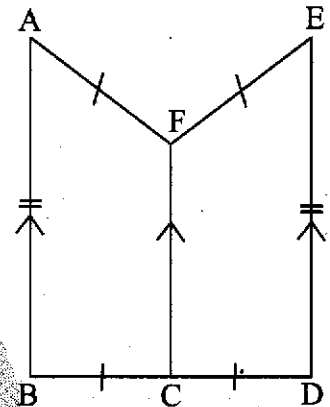

Calculate the area enclosed by the window in cm^2 .

- A. 150cm^2
 B. 75cm^2
 C. 120cm^2
 D. 60cm^2
16. A pipe can fill a tank in 12 hours. Another pipe can fill the same tank in 15 hours. The tank was empty and the two pipes were opened at the same time. How long did it take the two pipes to fill the tank with water?
- A. 27hours.
 B. $13\frac{1}{2}$ hours.
 C. 6hrs 20mins.
 D. 6hrs 40mins.

17. The mean mass of 8 boxes is 7.5kg. Seven of them weigh 12kg, 4kg, $6\frac{1}{2}$ kg, 5kg, 8kg, $8\frac{1}{2}$ kg and 9kg. Calculate the weight of the eighth box.
- A. 15kg
B. $7\frac{1}{2}$ kg
C. 8kg
D. 7kg
18. Arrange the fractions $\frac{3}{4}$, $\frac{2}{3}$, $\frac{5}{8}$ and $\frac{7}{12}$ in ascending order.
- A. $\frac{7}{12}$, $\frac{3}{4}$, $\frac{5}{8}$, $\frac{2}{3}$
B. $\frac{7}{12}$, $\frac{5}{8}$, $\frac{2}{3}$, $\frac{3}{4}$
C. $\frac{7}{12}$, $\frac{2}{3}$, $\frac{5}{8}$, $\frac{3}{4}$
D. $\frac{2}{3}$, $\frac{5}{8}$, $\frac{3}{4}$, $\frac{7}{12}$
19. A tailor made a loss of sh. 288 after selling a dress. If this represented 12% of the cost price. How much profit would he have made if he sold the dress for sh. 2950?
- A. sh. 2400
B. sh. 838
C. sh. 550
D. sh. 2662
20. There are 407 cows in a dairy farm. Each cow produces 12 litres of milk every day. 804 litres of the milk is fed to the calves. The rest is sold at sh. 40 per litre. How much money is collected from the sale of milk each day?
- A. sh. 195360
B. sh. 163200
C. sh. 32160
D. sh. 25968
21. Alice spends $\frac{1}{4}$ of her salary to pay school fees, $\frac{3}{8}$ to pay rent and a third of the remainder to buy food. He saves the rest which amounts to sh. 8500. How much money does she earn per month?
- A. sh. 68000
B. sh. 24000
C. sh. 25000
D. sh. 34000
22. Which digit is in the place value of hundredths after rounding off the product of 9.485 and 0.37 to the nearest hundredths?
- A. 1
B. 9
C. 0
D. 2
23. A tank was $\frac{3}{5}$ full of water. After using 145 litres it became a half full. Find the capacity of the water in the tank when full.
- A. 145L
B. 1450L
C. 290L
D. 81L
24. A $2\frac{3}{4}$ hour meeting started 30 minutes earlier than the time scheduled. If it ended at 1.30pm. At what time was it scheduled to start?
- A. 10.45am
B. 10.45pm
C. 10.15am
D. 11.15am
25. The rectangular tank drawn below holds 12000 litres of water when a third full.

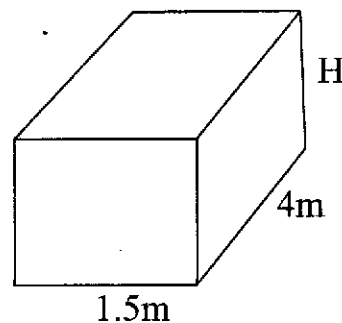

Calculate the height of the tank.

- A. 2m
B. 6m
C. 1m
D. 4m

26. Gerald deposited sh. 7000 in a bank. After 5 years he withdrew sh. 8750 which was the total amount of money available in his account. At what rate percent per annum was the money earning the interest?
- A. 7%
 B. 5%
 C. $2\frac{1}{2}\%$
 D. 3%

27. 12 workers were hired to paint a house in 15 days. However, 2 of them never turned up right from the first day. How much longer did it take for the work to be complete?
- A. 18 days.
 B. 6 days.
 C. 3 days.
 D. 60 days.

28. If $x = 5$, $y = 2$ and $z = x - 1$, what is the value of the following?

$$\frac{1}{3} \text{ of } \frac{x^2 + y}{x + z}$$

- A. 1
 B. 3
 C. 9
 D. 6
29. A 4% discount is allowed on all items whose marked price is below sh. 1000. A 5% discount is allowed on items whose marked price is above sh. 1000. Jacob bought two pairs of shoes each worth sh. 500 and a suit worth sh. 2000. How much money did he save as discount?
- A. sh. 140
 B. sh. 120
 C. sh. 130
 D. sh. 125

30. The length of the diagonals of a rhombus are 48cm by 20cm. Calculate the length of the rhombus.
- A. 25cm
 B. 52cm
 C. 50cm
 D. 26cm

31. Construct triangle XYZ such that line XY = 5cm, line YZ = 8cm and angle XYZ = 70°. Bisect angle YZX and let the bisector meet line XY at point O. What is the measure of angle YOZ?
- A. 72°
 B. 92°
 C. 88°
 D. 100°

32. The value of a car depreciated by 5% after every one year. If the initial value of the car was sh. 240 000, what was the value of the car at the beginning of the third year?
- A. sh. 205 700
 B. sh. 228 000
 C. sh. 216 600
 D. sh. 208 000

33. The figure below represents the area occupied by forest in a certain map whose scale reads 1:50000.

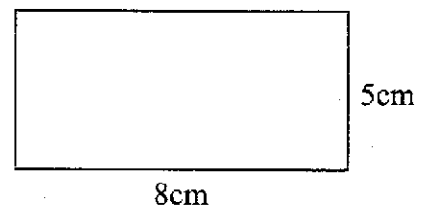

Calculate the actual area occupied by the forest in hectares.

- A. 40
 B. 1000
 C. 400000
 D. 10000

34. Emelda earns sh. 6500 as basic salary. She is also paid a commission on the value of goods she sells above sh. 50000. In one month she sold goods worth sh. 170 000 and earned a total of sh. 12500. What was her percentage commission?

- A. 10%
- B. 17%
- C. 5%
- D. 12%

35. The area of a square room is $5\frac{19}{25}$ m². Calculate its perimeter.

- A. $2\frac{2}{5}$ m
- B. 3m
- C. $9\frac{3}{5}$ m
- D. $5\frac{3}{9}$ m

36. Three motorists fuel their cars after 6, 8 and 12 days. If they all fueled their cars on April 1st, when did they fuel their car again on the same month?

- A. 12th April.
- B. 24th April.
- C. 13th April.
- D. 25th April.

37. Work out

$$\frac{7.5 \times 2.88 \times 0.5}{7.2 \times 1.5 \times 2.5}$$

- A. 0.8
- B. 0.008
- C. 0.04
- D. 0.4

38. How many more cubes would be required to complete this stack?

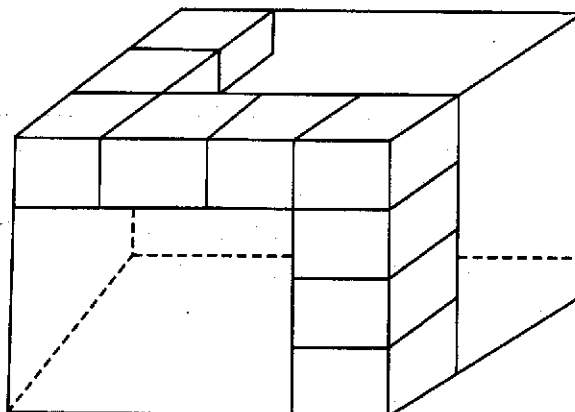

- A. 48
- B. 24
- C. 39
- D. 36

39. Solve the following inequality

$$\frac{1}{3}x + 2 > x - 4$$

- A. $x < 18$
- B. $x < 9$
- C. $x > 9$
- D. $x > 18$

40. The temperature of frozen ice was -17°C . It was warmed until the temperature rose to 79°C . What was the rise in temperature?

- A. 96°C
- B. 79°C
- C. 62°C
- D. 113°C

41. In the figure below line **ABCD** is parallel to line **EFG**. Lines **BFM** and **CFK** are transversals. If angles $\text{ABF} = 135^\circ$, $\text{BFC} = 90^\circ$ and $\text{MFG} = 32^\circ$, what is the size of the angle marked x ?

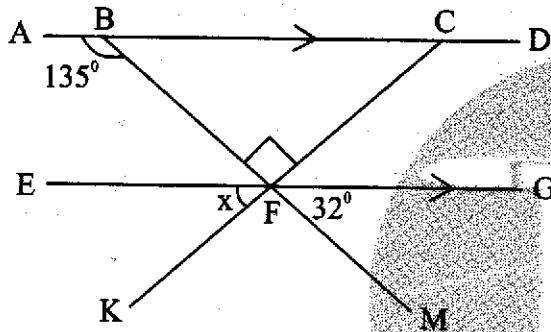

- A. 122°
 B. 58°
 C. 32°
 D. 45°

42. The cash price of a wardrobe is sh. 12000. The hire purchase price of the wardrobe is 15% more than the cash price. To buy the wardrobe on hire purchase the deposit is followed by 8 equal monthly instalments of sh. 1200 each. Calculate the deposit required.

- A. sh. 4200
 B. sh. 3600
 C. sh. 2400
 D. sh. 4000

43. Work out

$$\frac{2}{5} \text{ of } \left(3\frac{1}{3} + 1\frac{1}{3} \right) - 1\frac{1}{3} + 3$$

- A. $3\frac{1}{3}$
 B. $2\frac{2}{3}$
 C. $3\frac{2}{3}$
 D. $2\frac{1}{3}$

44. Calculate the volume of the triangular prism drawn below.

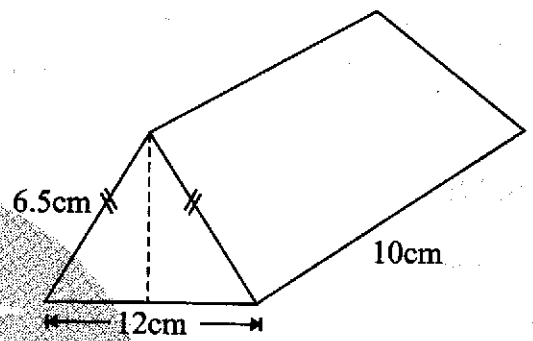

- A. 75cm^3
 B. 125cm^3
 C. 390cm^3
 D. 150cm^3

45. The table below shows commission charges for sending money by postal orders

Value of order (denomination)		Commission Charges	
sh	cts	sh	cts
5	00	5	00
10	00	5	00
20	00	7	00
50	00	12	00
100	00	20	00
200	00	35	00
500	00	80	00
1000	00	120	00

Simiu sent sh. 2315. What is the least commission payable to the post office for the money order?

- A. sh. 185
 B. sh. 305
 C. sh. 345
 D. sh. 240

46. A boy is x years old. His sister is 6 years younger. If their mother is three times her daughter's age, write an expression to show the total sum of their ages?
- A. $(3x - 18)$ years.
 B. $(5x - 12)$ years.
 C. $(5x - 24)$ years.
 D. $(5x + 12)$ years.

47. In the figure below BCD is a straight line, line AB is equal to line AD and angle $ABC = 45^\circ$.

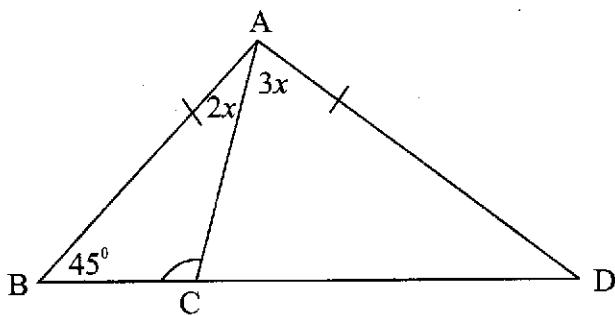

What is the size of angle BCA ?

- A. 36°
 B. 81°
 C. 54°
 D. 99°
48. A circular fish pond was fenced round using three strands of barbed wire. If the area of the pond is 154m^2 , calculate the length of the wire used.
- A. 154m
 B. 132m
 C. 44m
 D. 462m

49. A bag of beans weighs 75kg. Two such bags were repacked into equal 750g and $\frac{1}{4}$ kg packets. How many packets were obtained altogether?

- A. 75
 B. 25
 C. 150
 D. 300

50. The graph below shows the journey followed by Kimenjo from town V to town Z through towns W, X and Y.

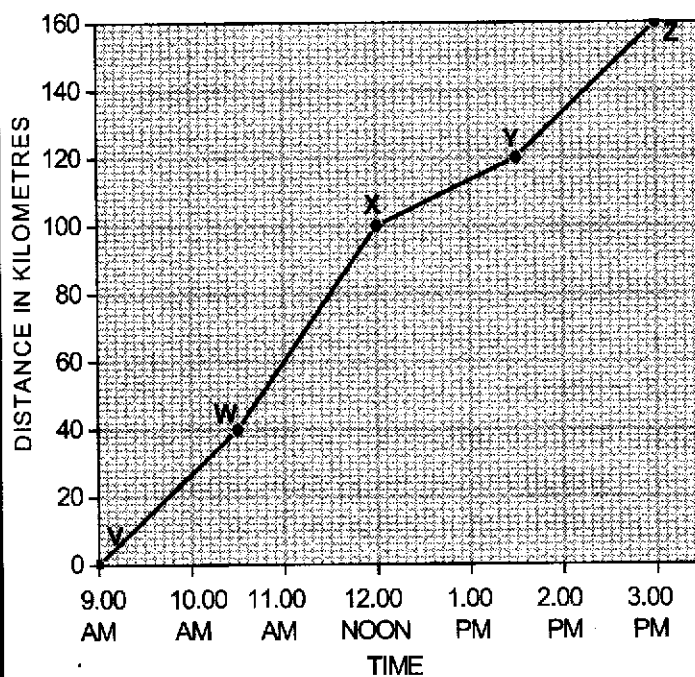

Between which two towns was he travelling at the highest speed?

- A. VW
 B. YZ
 C. WX
 D. XY

Read the passage below carefully. It contains blank spaces numbered 1 to 15. For each blank space, choose the best answer from the choices given.

The police 1 launched a massive hunt down 2 a man 3 to the killing of a 4 businesswoman. The 5 is said to have 6 as a police officer and 7 the house of Mrs. Matangi. Showing a 8 search warrant, he 9 to be let in where he shot down Mrs. Matangi 10 fleeing with an 11 amount of money. The area OCPD 12 that such cases are on 13 though he clarified that necessary 14 were already in 15 to curb the trend.

- | | | | | |
|-----|----------------|--------------|-----------------|-------------|
| 1. | A. had | B. has | C. have | D. have had |
| 2. | A. on | B. for | C. of | D. from |
| 3. | A. likened | B. risked | C. blamed | D. linked |
| 4. | A. famous | B. popular | C. celebrated | D. national |
| 5. | A. convict | B. suspect | C. criminal | D. culprit |
| 6. | A. trained | B. poised | C. posed | D. claimed |
| 7. | A. attacked | B. torched | C. broke into | D. invaded |
| 8. | A. fake | B. genuine | C. valid | D. secret |
| 9. | A. requested | B. demanded | C. pleaded | D. begged |
| 10. | A. after | B. including | C. before | D. except |
| 11. | A. uncountable | B. estimated | C. unbelievable | D. unknown |
| 12. | A. cited | B. sighted | C. denied | D. told |
| 13. | A. increase | B. decrease | C. top | D. demand |
| 14. | A. traps | B. weapons | C. tools | D. measures |
| 15. | A. order | B. place | C. action | D. time |

For questions 16 to 18, choose the best word that fills in the blank spaces.

16. All the members except Aoko _____ contributed for the tour.
A. have
B. has
C. will have not
D. has not
17. There was _____ milk left. We had to add another packet.
A. some
B. little
C. a little
D. much
18. Olang' is _____ happy to have been voted the cleanest boy in the school.
A. very
B. so
C. too
D. such

For questions 19 and 20, choose the opposite of the underlined word.

19. We saw them carrying a **gigantic** box.
A. slim.
B. huge.
C. light.
D. tiny.
20. They were instructed to **begin** their work immediately.
A. carry on.
B. give up.
C. wind up.
D. put off.

For questions 21 and 22, use the correct question tag to complete the given statement.

21. I have a new bicycle, _____?
A. have I
B. do I
C. haven't I
D. don't I
22. They rarely complain, _____?
A. does they
B. doesn't they
C. don't they
D. do they

For questions 23 to 25, choose the alternative that best replaces the underlined phrase.

23. The **exciting** match was **put off** by the heavy rainfall.
A. interrupted.
B. annoyed.
C. cancelled.
D. proceeded.
24. I **put on** a thrilling poem and won a prize.
A. presented.
B. built.
C. composed.
D. dressed.
25. The athlete **passed out** before he touched the finishing line.
A. drained.
B. died.
C. collapsed.
D. fainted.

Read the passage below and then answer questions 26 to 38.

As a matter of fact, we cannot deny the fact that human beings must depend on one another in many ways. A common saying goes that 'no man is an island'. It is not possible for any person to be so self-sufficient that he requires no assistance from his family, neighbours or the rest of the community. Traditions and customs of Africans encourage people to help others who may need help.

In rural areas, for example, people borrow and lend household items and tools. It is very common to see somebody borrowing cups from her neighbours when theirs are not enough for the visitors. Similarly, one may borrow a hoe from his neighbour. When such things are borrowed, it is expected that they will be returned to the owner as soon as possible. Such things are not to be kept for ever.

However, there is a different kind of borrowing that takes place between languages. For instance, a number of Swahili words doubtlessly come from the English language: words such as 'daktari', 'motokaa' and 'blanketi' are derived from English words doctor, motorcar and blanket respectively.

The English language has also borrowed some words from Kiswahili for example, jembe, mzee and safari. Moreover, both Kiswahili and English have equally borrowed words from other languages. Contrarily, borrowed words cannot be returned as in the case of other borrowed items. They are simply adopted into the language and become part of it.

Just as one language can be influenced by others so are people influenced by others. It is quite common to see people copy behaviour of those they admire. For example, a young girl may copy the way her favourite film star talks, walks or dresses. In learning institutions, pupils end up copying the behaviour of their teachers and may even copy a teacher's handwriting if they do admire it.

26. What is undeniable according to the first paragraph?
- A. No person can be self-sufficient.
 - B. Human beings have many facts and ways.
 - C. Human beings need not depend on one another.
 - D. Human beings must depend on their families.
27. The phrase '*... no man is an island*' has been used to advise the need of
- A. working together in unity.
 - B. using common English sayings.
 - C. following traditions and customs of Africa.
 - D. depending on one another in all ways.

28. Which one of the following terms cannot be used to mean the same?
- A. Assistance.
 - B. Aid.
 - C. Help.
 - D. Dependence.
29. Why would one borrow an item from the neighbourhood?
- A. The African traditions encourage so.
 - B. The items or tools he or she may have could be enough.
 - C. His or her visitors may be more than expected.
 - D. The customs in the rural areas allow borrowing.

30. What is expected after one borrows any item or tool from a neighbour?
 A. Buying a similar tool or item for themselves.
 B. Visitors feeling satisfied after the occasion.
 C. Keeping them clean for a little time.
 D. Returning them to the owner.
31. Which word bears the same meaning as 'common'?
 A. Usual.
 B. Obvious.
 C. Necessary.
 D. Amazing.
32. Borrowing of words differs from that of tools and items in that
 A. words look almost the same in pronunciation.
 B. words cannot be returned to the source.
 C. items and tools must be taken back to the owner.
 D. items and tools are only needed when they are not enough.
33. Which one of the following statements is not true about borrowing?
 A. It's normal to borrow household items in the country.
 B. African people help one another as their way of life.
 C. All Swahili words doubtlessly come from the English language.
 D. English as well as Kiswahili language have borrowed from other languages.
34. When words are adopted, it means that
 A. they are borrowed from another tribe.
 B. they can be kept for ever.
 C. they are contrary to other borrowed items.
 D. they have become part of the main language.
35. What does the author mean by '*... influenced by others...*'?
 A. People's characters can be affected by language.
 B. Language can be affected by people's character.
 C. One's character can be affected by someone's behaviour.
 D. Someone's behaviour can be affected by language.
36. Which one of the following is likely to bring a negative influence according to the passage?
 A. Walking or dressing like a favourite film star.
 B. Borrowing cups from the neighbour when there are visitors.
 C. Copying an admirable handwriting from the teacher.
 D. Having ambitions to excel like a famous super star.
37. Most of the film stars have the ability to influence behaviour because
 A. they come from the developed countries.
 B. their language is much more developed.
 C. they are celebrated by a good number of people.
 D. they are civilised and well educated.

38. Which is the main lesson learnt from the passage?
- A. School children copy their teacher's behaviour.
 - B. Anything borrowed should be returned after use.

- C. We need to borrow articles from others to be self-sufficient.
- D. Whatever is likely to benefit us is worth borrowing.

Read the passage below and then answer questions 39 to 50.

Never look back unless you want to go that direction. This slogan has been my **propeller** in this journey of life. I hardly complain or blame anyone for my condition. As far as my knowledge is concerned, I simply inherited the sickle-cell anaemia from either of my parents. This serious form of anaemia found mostly in people of African family origin is normally passed down from parents to children. The red blood cells are crescent-shaped instead of round-concave shape. This makes it very hard for these cells to carry enough oxygen to the body, causing chronic anaemia and episodes of extreme pain. The disease is not infectious but transferred from parents who carry the responsible genes notwithstanding their condition.

Though not curable, its treatment involves complex medication to reduce frequent pain, blood transfusions to replace deformed red blood cells and oxygen supplement in extreme cases. Bone marrow transplant is also another option though quite costly and a little life-threatening.

A sickle-cell crisis is an attack on the body when one is in too much and almost unbearable pain in the joints, arms and legs. This condition calls for regular hospitalization. It also requires one to be on medication everyday of their life time. Sometimes giving up seems the only option but I prefer taking the bull by the horns.

Sickle-cell anaemic individuals face stigma and challenges in the society. Due to misinformation, people take you for a weakling who can drop dead anytime. They look and talk to you differently.

However, I fight this condition with a very strong will power, I have learnt that what the other people think of me is none of my business. I work hard all day to prove myself that disability is not inability. I am focused and looking forward to achieving my childhood ambitions.

39. The writer considers the said slogan as a '**propeller**' in the journey of life. This means that
- A. it shows him or her the direction to go.
 - B. it warns him or her never to look behind.
 - C. it encourages him or her to live positively.
 - D. it tells him or her that life is a journey.

40. According to the writer's knowledge
- A. we should never go backwards.
 - B. life in general is a journey.
 - C. we should blame no one for our conditions.
 - D. sickle-cell condition is normally inherited from parents.

41. What does it mean by '*... I hardly complain...*'?
- I'm always grateful.
 - I seldom complain.
 - I never complain.
 - I occasionally complain.
42. Which one of the following is not a fact about sickle-cell anaemia?
- It is a common condition with Africans.
 - It can be passed from father to daughter.
 - It affects the red blood cells.
 - It is an infectious form of anaemia.
43. Cells affected by the anaemic condition have the following characteristics **except**
- they are malformed.
 - they have a round-concave shape.
 - they hardly carry enough oxygen to the body.
 - they are crescent-shaped cells.
44. The phrase '*notwithstanding their condition*' implies that
- a parent may be normal but still pass the sickle-cell condition.
 - sickle-cell anaemic parents can get normal children.
 - anaemic children can pass the condition to their parents.
 - normal parents experience shortage of oxygen.
45. Which one is not a remedy for chronic anaemia according to the passage?
- Replacement of red-blood cells through blood transfusion.
 - Regular check ups by a qualified medical expert.
 - Complicated medication to reduce frequent extreme pain.
 - Supplementing with oxygen in extreme cases.
46. Why would bone marrow transplant not be recommended to a person suffering from sickle-cell anaemia?
- It does not completely cure the condition.
 - It is one of the treatments meant to reduce pain.
 - It is too expensive for one to afford.
 - It can possibly lead to unexpected death.
47. A sickle-cell crisis requires
- too much unbearable pain in the joints, arms and legs.
 - a complex medication when the attack occurs.
 - daily medication throughout lifetime.
 - moderate hospitalization in case of an attack.
48. The writer has decided to tame the bull by the horns so as not to
- be concerned.
 - yield to temptation.
 - complain but blame someone.
 - seek costly and complex medication.
49. Why are individuals with sickle-cell condition treated differently by some people?
- They are physically challenged.
 - They are vulnerable weaklings.
 - They have stigma towards the society.
 - The society is not well informed.
50. Three strong lessons can be drawn from the last paragraph **except**
- negativity can be fought using a strong willpower.
 - our self-esteem should not be based on what others think about us.
 - childhood ambitions can hardly be achieved with focus.
 - with determination disability is not inability.

PART I: SOCIAL STUDIES.

KEZI AREA

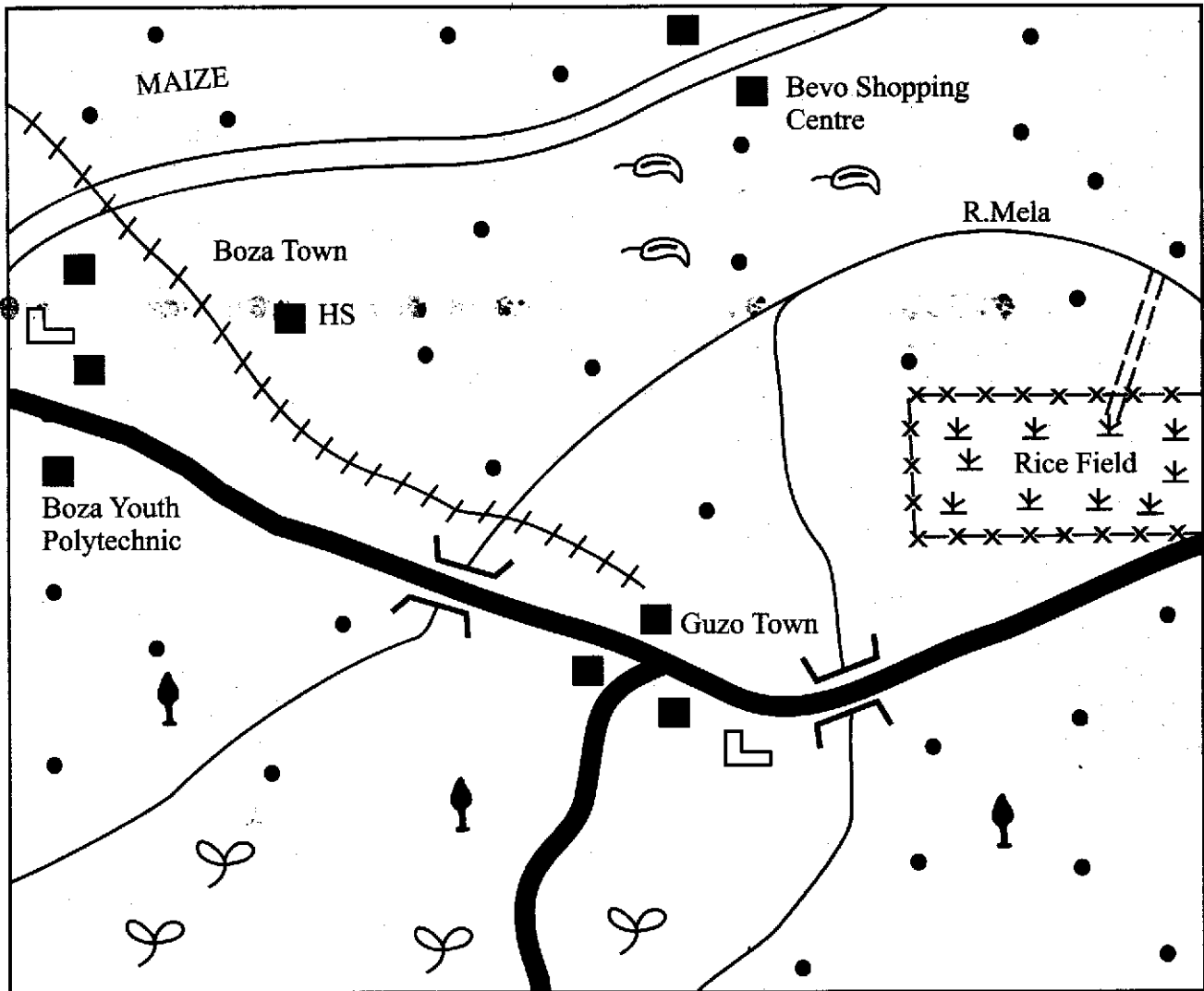

SCALE

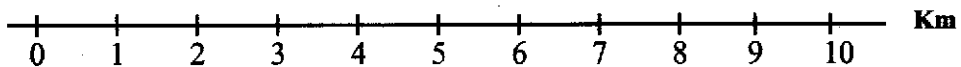

KEY:

Tarmac road	Human settlements	School
Murram road	Water canal	Hospital
Railway line	Banana farms	Forested areas
Built-up areas	Tea farms	River and bridge

Study the map of Kezi Area and answer questions 1 to 7.

1. Which one of the following statements about the climate of Kezi area is true?
 - A. Temperatures are cool and rainfall is high.
 - B. Rainfall is high and temperature is high.
 - C. Rainfall is low and temperature is high.
 - D. Temperatures are low and rainfall is low.
2. Which one of the following crops is **not** a food crop grown in Kezi area?
 - A. Maize.
 - B. Rice.
 - C. Bananas.
 - D. Tea.
3. The irrigation method used to irrigate rice in the rice field is
 - A. furrow method.
 - B. drip method.
 - C. canal method.
 - D. sprinkling method.
4. The **main** economic benefit of River Mela is that it is
 - A. a source of water for irrigation.
 - B. a source of fish.
 - C. a source of electricity.
 - D. a source of water for Guzo town.
5. The approximate area of the rice field is
 - A. 4km²
 - B. 8km²
 - C. 9km²
 - D. 12km²
6. Which one of the following crops can be grown in the Southern part of Kezi area?
 - A. Coffee.
 - B. Cloves.
 - C. Cocoa.
 - D. Sisal.
7. The general direction of Bevo Shopping Centre from Guzo town is
 - A. South.
 - B. East.
 - C. West.
 - D. North.
8. The interaction of the Bantu and the Galla people at Shungwaya during the migration period led to
 - A. Bantu acquiring weapons from the Galla.
 - B. Bantu migrating from the area.
 - C. Bantu learning crop growing from the Galla.
 - D. Establishment of a new language.
9. Emission of smoke by industries has mainly led to
 - A. deforestation in highland areas.
 - B. congestion of vehicles in towns.
 - C. increase of temperature on earth.
 - D. death of sea creatures.
10. Below are facts about a certain type of soil;
 - (i) It has fine particles
 - (ii) It is deposited by running water
 - (iii) It is called young soilThe soil described above is
 - A. alluvial soil.
 - B. clay soil.
 - C. sandy soil.
 - D. volcanic soil.
11. The coming of the white settlers to Kenya at the start of the 20th century led to
 - A. introduction of livestock farming.
 - B. introduction of subsistence farming.
 - C. introduction of fishing.
 - D. introduction of cash crop farming.

12. The **main** threat facing forests in the highland regions of Kenya is
- the increasing population.
 - frequent droughts in highland regions.
 - frequent fires in the forests.
 - construction of dams along rivers in the forests.
13. Which one of the following statements about the Early Stone Age period is **correct**?
- Tools were made from smelted iron.
 - Human beings grew crops.
 - Human beings made hunting tools.
 - Human beings built grass shelters.
14. School children participate in music activities in order to
- get marks during competitions.
 - promote cultural activities of communities.
 - interact with different children.
 - obey rules of their schools.
15. A windvane at a weather station is used to
- show where the wind is blowing from.
 - measure the speed of wind.
 - measure the strength of wind.
 - record the types of prevailing winds.
16. Kariandusi is an important historical site in Kenya because
- fossils of early man were found there.
 - it was settled by the early visitors.
 - the first mission school was built there.
 - it was a major slave market.

Use the map of Africa below to answer questions 17 to 20.

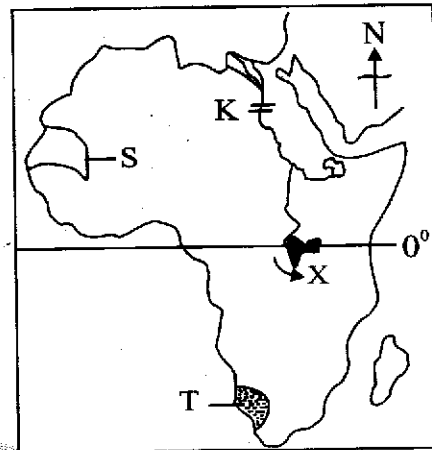

17. Which one of the following communities used the route marked X during migration?
- Khoikhoi.
 - Luo.
 - Galla.
 - Chagga.
18. Three of the following statements about the area marked T are true. Which one is **not**?
- The area receives about 250mm of rainfall.
 - The area has desert vegetation.
 - Day temperatures in the area are high.
 - The area has cool temperatures throughout the year.
19. The colonial administration method used by the Europeans in the country marked S was
- indirect method.
 - paternalism method.
 - direct method.
 - democratic method.

20. The **main** benefit of the river project marked **K** is that
- it has stopped flooding along the river.
 - it has increased food production in the area.
 - it has stopped siltation in the dam.
 - it has increased population in the area.
21. Most people who move to live in major urban centres are attracted by
- good recreational facilities in towns.
 - availability of cheap goods in towns.
 - availability of jobs in the towns.
 - the desire to be more civilised.
22. A civil marriage becomes legal when
- a marriage certificate is issued.
 - the couple gets children.
 - dowry is paid.
 - elders bless the couple.
23. The population of Germany grows at a low rate **mainly** because
- most people are not interested in children.
 - many children die when they are below 5 years.
 - people past reproductive age are more.
 - most people are educated.
24. Diatomite is extracted from area below the earth's surface using
- drilling method.
 - drenching method.
 - deep-shaft method.
 - opencast method.
25. Which one of the following ways is a forest conservation measure?
- Ploughing across the slope.
 - Planting grass in hilly slopes.
 - Setting aside areas as forest reserves.
 - use of charcoal for cooking.
26. Most fish in Japan come from
- fish farms.
 - the sea.
 - inland lakes.
 - salty water lakes.
27. The Nandi people in Kenya fought the British at the beginning of colonial rule because
- the British were moving into Nandi land.
 - the British were setting up schools.
 - the British forced the Nandi to grow tea.
 - the British were marrying Nandi women.
28. Which one of the following natural features attracts tourists in Zimbabwe?
- Okavango Swamp.
 - Coastal beaches.
 - Snow-capped mountains.
 - Victoria Falls.
29. Vasco da Gama visited the East Coast of Eastern Africa because he wanted to
- trade with the Coastal towns.
 - stop slave trade.
 - find a sea route to India.
 - preach Christianity.
30. Three of the following statements about the population of Kenya are correct. Which one is **not**?
- Most people live in towns.
 - Population is not evenly distributed.
 - High dependency ratio in most families.
 - More than half of the population consists of the youth.

Use the diagram below to answer questions 31 and 32.

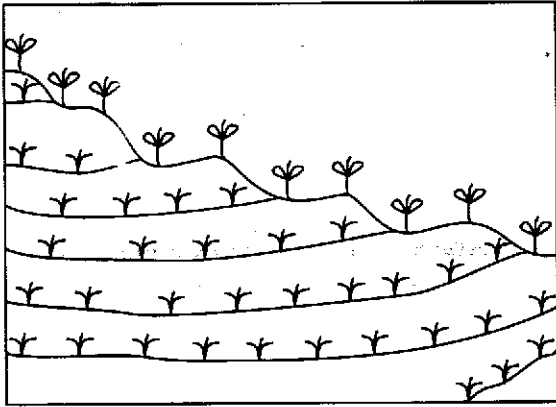

31. The soil conservation method illustrated above is
- monocropping.
 - terracing.
 - mulching.
 - agroforestry.
32. The soil conservation method illustrated above is used in
- steep areas with deep channels.
 - bare slopy land.
 - areas with little rainfall.
 - hilly cultivated areas.
33. Mwea Tebere Irrigation Scheme is located in
- Embu county.
 - Machakos county.
 - Kirinyaga county.
 - Murang'a county.
34. Tourist activities along the Coast of Kenya is **mainly** faced by the problem of
- pollution of the Indian Ocean.
 - insecurity to tourists.
 - poor roads in the region.
 - long distances between game parks.

35. Which one of the following activities is a first aid procedure at a road accident scene?
- Investigating the cause of the accident.
 - Telephoning the relatives of the injured people.
 - Covering bleeding cuts with clean clothes.
 - Arresting drivers who cause accidents.
36. Below are facts about a town in Kenya;
- It started as an agricultural market centre
 - It is fast growing as an industrial town.
 - It is located in a coffee growing area.
- The town described above is
- Nairobi.
 - Kisumu.
 - Mombasa.
 - Thika.
37. Before the coming of the Europeans the **main** function of a Maasai Laibon was
- performing major religious ceremonies.
 - dividing land among the people.
 - collecting taxes from traders.
 - teaching young people moral values.
38. River Congo carries the largest volume of water in Africa because
- it is very wide.
 - it flows through an area of high rainfall.
 - it has many tributaries.
 - it rises from highland area.
39. The government supports jua kali industries in Kenya by
- buying all goods made in jua kali industries.
 - exempting jua kali industries from paying taxes.
 - employing skilled school leavers.
 - giving people loans to start income generating activities.

40. Which one of the following ways is a form of modern communication system in Kenya?
- Transporting maize from Trans Nzoia to Mombasa.
 - Sending electronic mail message to a trader in India.
 - Sending flowers to Europe by air.
 - Pumping petroleum products from Nairobi.

41. Nelson Mandela contributed to political democracy in South Africa when he
- formed African National Congress (ANC).
 - led South Africa to independence.
 - led Africans to vote in elections.
 - led South Africa to join the African Union.

Use the diagram below to answer questions 42 and 43.

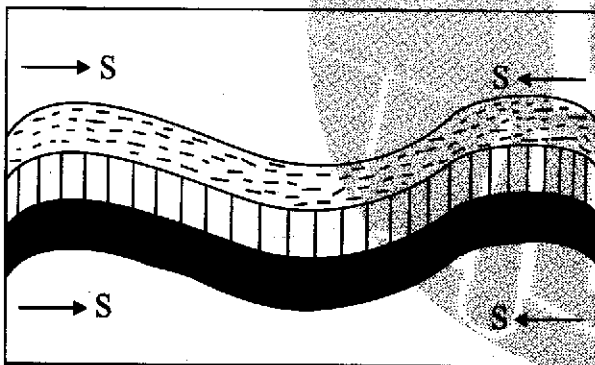

42. The forces marked S are
- compressional forces.
 - tensional forces.
 - faulting forces.
 - gravitational forces.
43. Which one of the following physical features was formed through the process illustrated above?
- Rift Valley.
 - Atlas mountains.
 - Lake Victoria.
 - Danakil depression.

44. Which one of the following groups consists of Semitic Speakers in Eastern Africa?

- | | |
|--------------------------------|----------------------------|
| A. Dahalo
Sanye
Sandawe | B. Pokomo
Taita
Hehe |
| C. Arabs
Amhara
Tigreans | D. Gabbra
Burji
Boni |

45. Before independence in 1980, Zimbabwe was known as
- Nyasaland.
 - Northern Rhodesia.
 - Basutoland.
 - Southern Rhodesia.

46. Which one of the following duties is performed by the head of state in Swaziland?
- Registering political parties.
 - Appointing a Prime Minister.
 - Chairing parliamentary debates.
 - Deciding election dates.

47. The British were interested in acquiring Nigeria during the scramble for Africa in order to
- have control of River Niger.
 - control the Trans Saharan Trade.
 - mine petroleum in the country.
 - stop slave trade.

48. Which one of the following is the best method of solving conflicts among pupils in schools?
- Litigation.
 - Mediation.
 - Dialogue.
 - Arbitration.

49. The Old Kingdom of Ghana was founded by
 A. Songhai people.
 B. Soninke people.
 C. Mandinka people.
 D. Fulani people.
50. Most settlement schemes were established in the highland regions in Kenya after independence because
 A. the highlands receive reliable rainfall.
 B. the highland regions were densely populated.
 C. people in the highlands did not have land.
 D. they were established on white settler farms.
51. The movement of educated Kenyans to live in other countries has **mainly** caused
 A. shortage of skilled labour in some professions.
 B. decrease of population in major towns.
 C. congestion of people in refugee camps.
 D. increase in rural-urban migration.
52. Excessive consumption of alcohol among the youth in Kenya has **mainly** led to
 A. increase in criminal activities in towns.
 B. increase in rural to urban migration.
 C. breakdown of social development.
 D. increase in school dropout.
53. The **main** benefit of voting during a general election is that
 A. voters get a chance to interact with candidates.
 B. voters are given money by candidates.
 C. voters are promised development by candidates.
 D. voters decide on who to govern them.
54. It is the responsibility of the government to
 A. protect citizens in their daily activities.
 B. put up places of worship for its citizens.
 C. form political parties.
 D. advise voters on who to vote for.
55. The Fulani people are able to graze over large areas in Nigeria because
 A. they live in a tsetse free area.
 B. the land they occupy is sparsely populated.
 C. the area they live receives high rainfall.
 D. the land they occupy has plenty of grass.
56. The African Union (AU) has its head office in
 A. Lusaka.
 B. Abuja.
 C. Arusha.
 D. Addis Ababa.
57. Which one of the following is a friendly environment for persons with disabilities?
 A. Buildings with sloping ramps.
 B. Roads with zebra crossing.
 C. Roundabouts with traffic lights.
 D. Road signs that are marked in white.
58. Which one of the following drugs in Kenya is legal but **most** commonly abused?
 A. Alcohol.
 B. Khat.
 C. Cocaine.
 D. Bhang.
59. On a polling day in Kenya, a voter is **not** allowed to
 A. observe counting of votes.
 B. mark ballot papers.
 C. witness sealing of ballot boxes.
 D. count the votes.
60. Which one of the following statements about the constitution of Kenya is **true**?
 A. It was adopted from European colonialists.
 B. It is written by parliament.
 C. It outlines functions of government departments.
 D. It was written before independence.

Soma vifungu vifuatavyo. Vina nafasi 1 mpaka 15. Kwa kila nafasi umepewa majibu manne. Chagua jibu lifaalo zaidi.

Ufisadi ni janga 1 tangu enzi za mababu zetu. Viongozi wa wakati huo 2 maana ya methali 3 wanalikabiliana nao kabla ya visa hivyo vya ufisadi 4. Ufisadi ni uovu 5 kukemewa na kupigana nao kwa 6. Tume ya kupambana na ufisadi 7 fedha za kutosha 8 shughuli zake, huenda tukapiga hatua kukabiliana na tatizo hili sugu.

- | | | | | |
|----|-----------------------------------|----------------------|---------------------------------|-----------------------|
| 1. | A. ambayo imekuwepo | B. ambalo limekuwepo | C. ambalo imekuwepo | D. ambacho kimekuwepo |
| 2. | A. walijua | B. wangejua | C. wanalijua | D. wasingalijua |
| 3. | A. usipoziba ufa utajenga ukuta | | B. jungu kuu halikosi ukoko | |
| | C. ukicha mwana kulia utalia wewe | | D. ukibebwa usilevyelevye miguu | |
| 4. | A. kudidimia | B. kupungua | C. kukithiri | D. kukidhiri |
| 5. | A. linalostahili | B. unaostahili | C. analostahili | D. linalostahili |
| 6. | A. raha na buraha | B. heri na shari | C. upole na haraka | D. jino na ukucha |
| 7. | A. ikitengewa | B. inatengewa | C. ingetengewa | D. ikatengewa |
| 8. | A. kununulia | B. kutozwa | C. kugharimia | D. kugharamia |

Kristina aliamua 9 shuleni. Juhudi za walimu kumshawishi afanye bidii hazikufanikiwa. Matokeo ya mtihani wa kitaifa wa darasa la nane 10, ajabu ni kuwa alizoa alama za 11. Alikitazama cheti chake kilichokuwa mikononi 12 asiweze kuamini. Alivuta fikra na kuona jinsi 13 kwenye anasa na kupuuza masomo. Machozi 14 njia mbilimbili. Wazazi wake walimshauri arudi shuleni tena 15 umri wake bado ulikuwa mdogo. Safari hii hakufanya ajizi.

- | | | | | |
|-----|--------------------|------------------|-------------------|-------------------|
| 9. | A. kulaza damu | B. kufanya bidii | C. kufa damu | D. kupiga shoti |
| 10. | A. ulipotangazwa | B. ilipotangazwa | C. zilipotangazwa | D. yalipotangazwa |
| 11. | A. kushangaa | B. kushangaza | C. kushangazwa | D. kushangiliwa |
| 12. | A. mwake | B. yake | C. pake | D. kwake |
| 13. | A. alivyojitoma | B. alivyojinasua | C. alivyojiamisha | D. alivyojichomoa |
| 14. | A. yalimlengalenga | B. yalimsonga | C. yalimwagika | D. yalimbubujika |
| 15. | A. ingawa | B. mradi | C. maadamu | D. minghairi ya |

Kutoka swali la 16 mpaka 30, chagua jibu lililo sahihi.

16. 'Ka' imetumiwaje katika sentensi; Mama alipika pilau, akala, akaosha vyombo, akaoga, akalala?
A. Kuonyesha hali ya masharti.
B. Kuonyesha hali ya kuendelea kwa matukio.
C. Kuonyesha hali ya wakati uliopita.
D. Kuonyesha hali ya mfuatano wa matukio.
17. Chagua sentensi inayoonyesha matumizi sahihi ya **lau**?
A. Lau mwalimu anapofundisha husimama.
B. Nipe lau shilingi tano ninunue kaukau.
C. Lau ungefika mapema ungekutana na mwalimu wetu.
D. Lau mtu anapofunga ndoa watu husherehekea.
18. Sentensi, '**karemba amekwenda kwao**' ina maana mbili. Zichagua
A. (i) Amekwenda alikozaliwa.
(ii) Amekwenda mbali na kwao.
B. (i) Amekwenda alikozaliwa.
(ii) Amekwenda kwa watu wengine.
C. (i) Amekwenda kwa watu wengine.
(ii) Amekwenda mbali na kwao.
D. (i) Amekwenda kwa mtu mwingine.
(ii) Amekwenda mbali na kwao.
19. Maana ya '**ungalifika ungalinisaidia**' ni
A. ulifika lakini hukunisaidia.
B. ulifika na ulinisaidia.
C. hukufika wala hukunisaidia.
D. hukufika ila ulinisaidia.
20. Chagua usemi taarifa ufao wa sentensi: 'Ondoeni madaftari yenu hapa kila siku,' mwalimu aliwaambia wanafunzi.
A. Mwalimu aliwaambia wanafunzi kuwa anataka wayaondoe madaftari yao hapo kila siku.
B. Mwalimu aliwaambia wanafunzi kuwa angetaka wayaondoe madaftari yao hapo kila siku.
C. Mwalimu aliwaambia wanafunzi kuwa yeye hutaka wayaondoe madaftari yao hapo kila siku.
D. Mwalimu aliwaamuru wanafunzi wayaondoe madaftari yao hapo kila siku.
21. Chagua jibu lenye vivumishi visivyochukua viambishi vya ngeli
A. dhaifu, ghali, hodari.
B. zuri, baya, safi.
C. gumu, safi, karimu.
D. bora, hodari, chema.
22. Akisami $\frac{7}{9}$ huitwa
A. sudusi saba.
B. subui saba.
C. tusui saba.
D. thumni tisa.
23. Chagua neno lenye maana sawa na **maadamu**
A. Mradi.
B. Isipokuwa.
C. Pasipo.
D. Kwa kuwa.
24. Chagua jawabu lisilo sahihi
A. Sura ni sehemu katika kitabu iliyogawanywa.
B. Sura ni umbile la mtu au nyama lililo usoni.
C. Sura ni mpango wa matundisho ya elimu maalum.
D. Sura ni kutoa ushuzi.
25. Wingi wa, '**mtume amemtuma padri akaupeleke ujumbe**' ni
A. Mitume wamewatuma mapadri wakapeleke jumbe.
B. Watume wamewatuma mapadri wakalipeleke ujumbe.
C. Mitume wamewatuma padri wakazipeleke jumbe.
D. Mitume wamewatuma mapadri wakazipeleke jumbe.

26. Shaibu ni kwa ajuzi kama vile mwananyumba ni kwa
A. mkemwenza.
B. mjakazi.
C. mkazamwana.
D. mwanamwali.

27. Kitenzi, 'soma' katika kauli ya kutendea ni
A. somesha.
B. somea.
C. someka.
D. somasoma.

28. Kamilisha methali
Siri ya mtungi
A. aijuaye chungu.
B. aijuaye debe.

- C. aijuaye kopo.
D. aijuaye kata.

29. Jibu la kitendawili
Nikicheka anacheka, nikinuna ananuna ni
A. maji.
B. moto.
C. kioo.
D. picha.

30. Bainisha matumizi ya 'karibu' katika sentensi
Geteri ameanguka karibu avunjike mguu.
A. Kuonyesha makaribisho.
B. Kuonyesha nusura.
C. Kuonyesha kiasi.
D. Kuonyesha wakati.

Soma kifungu kifuatacho kisha ujibu maswali 31 mpaka 40.

Amani ni utulivu au hali ya kuwa na usalama bila ghasia au vita. Hali hii ya mtu binafsi kukaa kwa utulivu miongoni mwa watu wa aila moja au katika jamii pana ndilo alilokusudia Mungu. Alipowaweka Adamu na Hawa katika bustani ya Edeni, wawili hawa walikaa kwa utulivu na viumbe wote, wadudu na nyuni wa angani, wala hakuna aliyemzoza mwenzake. Lau sio dhambi ya mwanadamu iliyoleta mafarakano baina ya mtu na wanyama na hatimaye wivu wa Kaini dhidi ya nduguye Abeli, tungekuwa na aushi tulivu kabisa.

Utangamano baina ya binadamu huwezekana kwa sababu ya amani. Uelewano huu hutufanya tujue mengi kutoka kwa wenzetu. Maulana alituhuluku tukiwa na akili na uwezo wa viwango tofauti ili tufaane. Anayetangamana na wenzake hupata kuelewa mbinu wanazotumia ili kustawi, naye akazitumia na kupiga hatua. Haifai kuona gere au inda mtu anapokupiku katika hili na lile. Muhimu ni kujitahidi na labda kumwiga au kutumia mbinu zinazokaribiana na zake na ikiwezekana umkaribie katika ufanifu au hata kuwa bora kumshinda.

Kuingiliana na kufaana kwa kila jambo huletwa na amani. Binadamu aliyejitosheleza kwa kila kitu hajawahi kuonekana. Utangamano huwafanya watu kuhisi kama wana vyote wanavyohitaji. Huyu akimwazima mwenzake kinu, naye yule anayeazima kinu, mchi wake unaweza kuvunjika kesho, amwazime mwenzake. Mradi itakuwa hali ya kufaana kwa la jua na kwa la mvua. Hii ndiyo huwafanya waja wasio na vyote wanavyohitaji kukaa maisha ya utele; cha huyu kinakuwa cha yule na cha yule kuwa cha huyu. Amani huwafanya watu hatimaye kuonekana wakiwa na usawa. Ukipata mwapata nyote, akikosa mwakosa nyote kisha mnapeana moyo wa matumanini.

Utendakazi katika jamii huwa rahisi panapokuwa na amani. Kwanza mtu huweza kuzitimiza shughuli zake za kulisukuma gurudumu la maisha bila kuhofia jicho la jirani. Ni rahisi pia kuwa na msaragambo hasa katika kazi za kuifaa jamii pasi kujali kabila wala koo. Kazi kama kukarabati kisima kijijini au kurekebisha barabara iharibikapo huifaa jamii nzima. Umoja na hisia ya udugu ndicho kigezo kikuu cha kuiendeleza jamii kwa jumla.

Amani huwezesha kuwa na utulivu kazini. Matalani shughuli za zaraa huendelea bila kuchachawizwa ambapo upandaji na uvunaji hutendeka katika majira yafaayo. Jamii iliyo na amani hupata chakula cha leo na akiba ya kesho. Kazi za ujira pia hufanyika vyema kwani waajiriwa huenda kazini bila wahaka na kuzifanya gange zao bila mpapatiko nyoyoni. Wafanyabiashara halikadhalika huendesha shughuli zao bila wasiwasi wa kuharibiwa walivyowekeza. Kunawiri kwa biashara ni ishara ya kunawiri kwa jamii na dola kwa jamii.

Uthabiti wa taifa huletwa na amani. Mataifa mengine hushirikiana na nchi yoyote ile iliyo na amani kuimarisha maisha ya wananchi. Nchi isiyo na amani hunyimwa usaidizi na misaada. Ni bayana kuwa amani huchangia pakubwa katika ustawi wa mtu binafsi, jamii, nchi na ulimwengu kwa jumla. Ni jukumu letu sote kuhakikisha kuwa tunadumisha amani na nafsi zetu na wenzetu na tuelewe kuwa ukosefu wa amani ni chembe cha maangamizi na mvuruga amani ni hasidi mkubwa wa maendeleo.

- 31.** Kulingana na aya ya kwanza
- Adamu na Hawa hawakuwa na jukumu la kukaa na amani na viumbe wengine.
 - kuwa na usalama, utulivu wa mtu binafsi na kutozozana na wengine ndiyo amani.
 - dhambi ya mwanadamu sio chanzo cha mafarakano baina ya watu na wanyama.
 - halikuwa kusudi la muumba kumuumba binadamu mwenye wivu.
- 32.** Chagua jibu lisilo sahihi kulingana na kifungu
- Amani ikiwepo binadamu huishi kwa utangamano.
 - haifai kumwonea mtu wivu anapokushinda kwa hili au lile.
 - utulivu katika jamii huwa kikwazo kikubwa katika utendakazi.
 - nchi isiyotetereshwa huwa madhubuti kisiasa na watu wake huwa makini kuimarisha.
- 33.** Aya ya tatu imebainisha kwamba
- mtu aliyejitosheleza katika maisha haishi na watu wengine katika jamii.
 - si vyema kuvunja kinu na mchi ulioomba.
 - watu wanastahili kufaana kunaponyesha tu.
 - hakuna mwanadamu hamhitaji mwanadamu mwingine katika maisha ya kawaida.
- 34.** Mtu anayetangamana na wenzake
- hujifunza mbinu za kumsaidia afanikiwe ili awe bora maishani.
 - huwa na inda wenzake wanapostawi zaidi kumshinda.
 - hushindwa kupiga hatua kwa sababu ya ushindani mkubwa.
 - huzua rabsha na kueneza uvumi kuhusu mbinu za wenzake za kufanikiwa.
- 35.** Ni methali gani inafaa zaidi maelezo ya aya ya nne?
- Achanikaye kwenye mpini hafi njaa.
 - Kinga na kinga ndipo moto uwakapo.
 - Mbwa hafi maji akiona ufuko.
 - Hamadi kibindoni silaha iliyo mkononi.
- 36.** Mtazamo wa mwandishi katika aya ya nne ni kwamba
- kuwepo kwa amani katika jamii huwezesha kila mtu kujiendeleza binafsi.
 - ukabila ni kigezo kikuu cha kuleta maendeleo katika jamii.
 - ni vyema kumwogopa jirani kwani hujui analofikiria kukuhusu moyoni mwake.
 - kila mwanajamii abebe mzigo wa kusukuma gurudumu la maisha yake.

37. Kwa mujibu wa aya ya tano: Amani
- huchochea uzembe wa watu na kuzifanya kazi zao kusimama.
 - huwezesha kila mja kutia bidii katika kazi na kuzalisha matunda mema.
 - huleta wasiwasi katika nyoyo za wanadamu.
 - huchangia ukosefu wa hela na chakula nchini.
38. Kwa mujibu wa aya ya mwisho nchi isiyo na amani
- hupewa msaada wa kujikomboa kutoka ghasia.
 - hunufaika kutokana na uthabiti wa mataifa mengine yaliyoimarika.
 - hutengwa na nchi nyingine na hata kunyimwa usaidizi wa aina yoyote ile.

D. huimarisha maisha ya nchi na wananchi wake.

39. Maana ya msaragambo kulingana na kifungu ni
- kuzua vita baina ya watu wanaofanya kazi.
 - kung'ang'ania raslimali zilizoko katika jamii.
 - kuvurugana na watu wengine wa jamii yako.
 - kushirikiana na wengine katika kazi bila kulipwa.
40. Kichwa kinachofaa zaidi taarifa hii ni
- Amani Nchini Mwetu.
 - Amani Haiji ila kwa Ncha ya Upanga.
 - Umuhimu wa Amani.
 - Jinsi ya Kuimarisha Amani.

Soma kifungu kifuatacho kisha ujibu maswali 41 mpaka 50.

Tuliingia garini na dereva wa kike, kwa jina Rasha, akaliwasha moto na kuliondosha kwa njia ya kipekee. Alishika usukani kwa mkono wa yamini huku ule mwingine ukikamata kigoe cha kubadilisha gia. Mara tu tulifika kwenye mzunguko wa barabara na gari letu likageuka na kushika barabara kuu ya kuelekea jijini Giza.

Japo tulisukwasukwa garini kama maziwa ndani ya kibuyu kutokana na hali ya barabara, mwendo wetu ulikuwa wastani na tulipishana na magari kadhaa njiani. Niliona matrela yanayokokota mabehewa ya kila aina. Mabasi ya rangi zote yalitupita huku yakipiga honi zao kuzindua madereva wenye magari madogo. Baada ya muda mfupi tulifika kwenye mlima maarufu utwao Tweta. Mbele yetu kulikuwa na lori kubwa lenye shehena. Rasha alilazimika kukanyaga breki ghafla na kupunguza kasi. Hatukuweza kupita kwa sababu kulikuwa na upete manjano katikati ya barabara. Tulipomaliza upinde, mstari manjano ulianza kukatikatika. Barabara ilikuwa laini na dereva akachapuzwa gari.

Muda huo wote nilikuwa makini nikisoma ishara za barabarani. Baada ya kufika Nyakoe niliona ishara ya mpindo. Mbele kidogo barabara ilianza kupindapinda. Ilimlazimu dereva kukanyaga breki mara kwa mara. Nilipomwuliza chanzo cha harufu ya mpira kuchomeka, alinjibu, "Ni msugvano wa padi za gari."

Masafa machache mbele hali ya barabara ilianza kuharibika; lami ilikuwa imechubuka na kuacha mabonde. Tulipunguza mwendo huku tukijaribu kuranda kulia na kushoto kwa lengo la kuhepa mashimo. Magari mawili yalikuwa yamegongana kando ya barabara huku trafiki wakipima kwa utepe na kudadisi na kuandika. "Ajali hii lazima imesababishwa na mpando huo," nilijiwazia.

Baada ya Mosochi, barabara ilikuwa shwari isipokuwa matuta ya kupunguza mwendo. Hakukuwa na ishara yoyote na gari letu lilidunda karibu livunje springi. Karibu na Matieko, niliona kipande cha chuma cha pambetatu kimeandika, "kizuizi cha polisi". Tulisimama na baada ya ukaguzi, walitutakia safari njema. Niliona mabango ya kuonya madereva juu ya wanyama, mengine makubwa yaliona kuhusu kutangaza bidhaa mbalimbali. Nilivutiwa zaidi na kima waliosimama juu ya mti aina ya mparachichi.

Ghafa mvua ilianza kunyesha kidindia. Dereva aliwasha waipa japo tuliona kwa shida. Barabara ikawa telezi na magari yakawasha taa na kuenda polepole. Ukungu ulishamiri. Tayari gari moja lilikuwa limelala chali. Nadhani dereva alipuuza ishara za barabarani.

Mbele kidogo ishara ya njiapanda ilijitokeza nasi tulifuata ya kushoto. Hapa barabara ilikuwa kavu na laini. Nilishangazwa na jinsi magari yalivyobugunya masafa, yote yakielekea upande mmoja. Kufumba na kufumbua tuliingia jijini Giza. Kulikuwa na mlolongo wa magari yaliyofuatana unyonyo mwendo wa kinyoroga. Lakini 'matatu' ziliyapita magari mengine upesi na kuomba kupishwa kwa ishara ya mkono. Yalipuuza m... amizi ya taa za barabarani.

Muda si muda, nilihisi gari letu likiyumbayumba kumbe ilikuwa ni pancha. Lakini tulipata mahali pa kuegesha karibu na mpitomilia. Baada ya kulibadilisha gurudumu tuliendelea na safari yetu salama salimini.

41. Chagua jawabu lisilo sahihi kulingana na aya ya kwanza
- gari liliondoshwa stani kwa mtindo wa aina yake.
 - dereva alishika usukani kwa mkono wa kulia.
 - mkono wa kushoto wa dereva ulishika kigoe cha kubadilisha gia.
 - gari lilipopita mzunguko, dereva aliongeza kasi yake.

42. Kurushwarushwa garini kulitokana na nini?
- Barabara iliyokuwa mbovu.
 - Gari lililokuwa katara.
 - Mwendo wa wastani wa dereva.
 - Magari mengi yaliyokuwa barabarani.

43. Maana ya 'akachapuzi gari' ni
- akapunguza kasi.
 - akaongeza kasi.
 - akaliondoa gari barabarani.
 - akalisimamisha gari.

44. Kulingana na aya ya tatu, chagua alama ya barabara iliyokuwa Nyakoe.

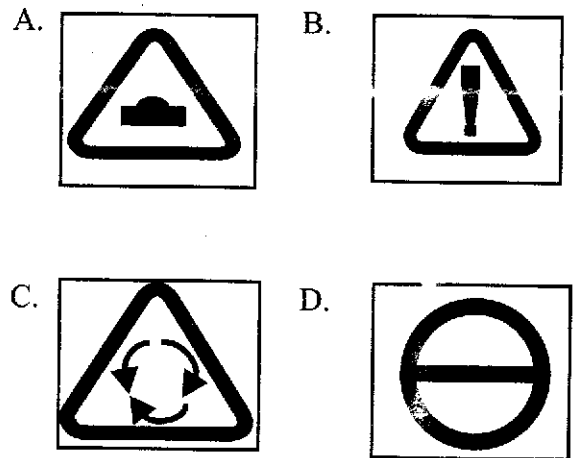

45. Ni ajali ngapi zilizotajwa katika kifungu?
 A. Moja.
 B. Tatu.
 C. Mbili.
 D. Nne.
46. Kulingana na kifungu, dereva alilazimika kutoka upande wa kulia hadi ule wa kushoto kwa kuwa
 A. alitaka kukwepa mashimo.
 B. alitaka wafike haraka.
 C. alitaka kuhepa asigonge magari mengine.
 D. magari yalikuwa yamegongana.
47. '*Ghafla mvua ilianza kunyesha kidindia*' maana ya kifungu hiki ni
 A. mvua ilinyesha kwa wingi.
 B. mvua iliacha kunyesha.
 C. mvua ilinyesha bila kikomo.
 D. mvua ilinyesha ndogondogo.
48. Kulingana na aya ya sita ajali husababishwa na
 A. mvua inayosababisha barabara kuwa telezi.
 B. madereva kutofuata sheria za barabarani.
 C. kuendesha magari kwa kasi.
 D. ukungu mwingi barabarani.
49. Wasafiri walipokaribia jijini Giza
 A. magari yaliendesha polepole.
 B. magari yalipishana kwa kasi.
 C. gari lao lilipata ajali.
 D. magari yalielekea pande tofauti tofauti.
50. Maana ya methali, 'mwenye nguvu mpishe' imejitokeza katika kifungu hiki inadhihirishwa na
 A. magari kuendesha mwendo wa kinyonga kwenye msongamano.
 B. magari yote yalisimama kukaguliwa na polisi kabla ya kuendelea na safari.
 C. matatu ziliyapita magari mengine bila kujali sheria za barabarani.
 D. ajali nyingi zilitokea barabarani.

1. Which one of the following statements is correct about fertilization in human beings?
 - A. Occurs when embryo is formed.
 - B. Occurs when sperms are deposited in the vagina.
 - C. Occurs when cell division starts.
 - D. Takes place in the oviduct.
2. Drugs can be misused in all the following ways **except**
 - A. taking a wrong dosage.
 - B. sharing drugs with a friend.
 - C. taking less drugs than recommended.
 - D. buying medicine with doctor's prescription.
3. Flea in livestock affects all the following **except**
 - A. pigs.
 - B. poultry.
 - C. rabbit.
 - D. sheep.
4. The shape of a bird's beak can be used to tell
 - A. the size of eggs the bird lays.
 - B. the type of movement the bird has.
 - C. what the bird feeds on.
 - D. the number of eggs the bird lays.
5. Mulches are **mainly** used in the farm to
 - A. prevent splash erosion.
 - B. prevent the growth of weeds.
 - C. conserve soil moisture.
 - D. provide organic matter after decomposition.

6. The **main** function of a swim bladder in fish is to
 - A. enable the fish to swim swiftly.
 - B. help the fish to float even when not swimming.
 - C. help to reduce friction when the fish is swimming.
 - D. help the fish balance in water and propel forward.
7. Which one of the following signs of ill health in animals is **not** immediate?
 - A. Blood in stool.
 - B. Rough coat.
 - C. Loss of weight.
 - D. Coughing.
8. A patient visited a doctor and had a painless sore on the penis and swollen lymph glands. Which STI was the patient **most likely** to be suffering from?
 - A. Syphilis.
 - B. Chancroid.
 - C. Gonorrhoea.
 - D. AIDS.
9. The animal below is adapted to movement in all the following **except**

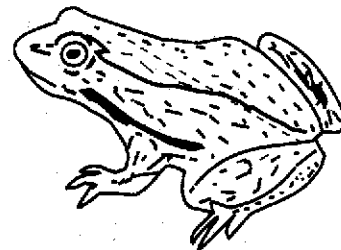

- A. has strong hind limbs to leap in water.
- B. has streamlined body to swim in water.
- C. has the body covered with a moist skins to swim easily.
- D. has strong hind limbs to hop on land.

10. Aerosol sprays destroy the ozone layer which leads to
- reduction of the rays from the sun.
 - increase in oxygen in the air.
 - thinning of the ozone layer.
 - green house effect.

11. Weight can be described as
- the matter content in an object.
 - the volume of matter in an object.
 - the force of resistant in air when an object is lifted.
 - the amount of force of gravity acting on an object.

12. The following are all excretory organs except one. Which one is it?
- Kidneys.
 - Lungs.
 - Nose.
 - Skin.

13. To reflect heat and light away by a xerophytic plant, it is adapted by having
- thick waxy cuticle.
 - silvery hairs on leaves.
 - normal hairs on the leaf surface.
 - deep wide spread roots.

14. Std. 6 pupils carried out an activity below.

- Put water in a container
- Added soap powder and made foam
- Using a straw or clean tube, they blew air into the water to make bubbles

Which one of the following were they likely trying to demonstrate?

- Reflection of light.
- Refraction of light.
- Making a rainbow.
- Making a liquid thermometer.

15. Which group of pastures below will provide animals with proteins when fed?
- Lucern, napier grass, desmodium.
 - Glycine, clovers, desmodium.
 - Beans, peas, groundnuts.
 - Oats, molasses, sweet potato vines.

16. The following are ways of conserving water except one, Which one?
- Shading.
 - Storing in dams.
 - Harvesting.
 - Using for irrigation.

17. The following are symptoms of a certain communicable disease:

- Sweating at night
- Loss of weight.
- Chest pains.
- Fever
- Prolonged cough

The disease is likely to be

- Malaria.
- Typhoid.
- Tuberculosis.
- Whooping cough.

18. Class five pupils carried out the experiment below:

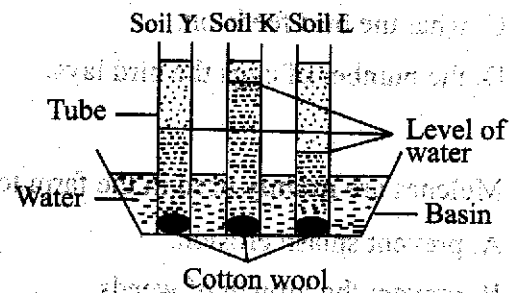

The pupils found out that soil L has the following characteristics except

- has the best drainage.
- has the lowest capillarity.
- becomes water logged easily.
- has largest air spaces and is coarse.

19. Irene, a kitchen worker, observed a stain on the walls of the kettle that was used to heat water. It could be caused by
- steel wool and soap.
 - soft water.
 - tea.
 - hard water.

20. Std. 5 pupils of Kipkelion primary school set up the experiment shown below.

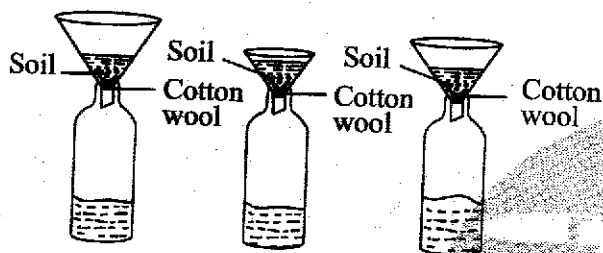

The experiment did not work well. Which of the following is the mistake they made when setting up the experiment?

- Using funnels of different sizes.
 - Adding equal amount of water.
 - Using collecting jars of different sizes.
 - Having equal amount of cotton wool.
21. Which one of the following is **not** a sign of unhealthy crop?
- Curled leaves.
 - Robust growth.
 - Wilting.
 - Malformation and distortion.

22. The following are ways in which the environment is polluted:

- Use of excess fertilizers
- Dumping of industrial wastes
- Smoking cigarettes
- Aerosol sprays
- Burning tyres
- Industrial waste gases
- Vehicle exhaust fumes

Which group of the above activities pollutes air **only**?

- i, ii, vii, iv
- ii, iv, v, vi
- iii, vii, iv, v
- v, iv, i, ii

23. A bicycle in motion comes to a stop when brakes are applied due to
- heat produced between the brakes and the tyres.
 - friction between the brakes and the road.
 - the treads of the tyres.
 - friction between the brakes and the rim.

24. The **best** method for softening temporary hard water is by
- filtering.
 - adding chemicals.
 - boiling.
 - using soap while washing.

25. The next step to follow when separating a mixture of salt and pieces of copper after dissolving is
- passing a magnet.
 - filtering.
 - evaporating.
 - adding water.

26. The part of food that has no nutritive value, not digested and is got from fruits and vegetable helps to
- prevent dehydration.
 - absorb food in the intestine.
 - prevent constipation.
 - produce juice that completes digestion.
27. During breathing, air is cleaned, warmed and moistened in the
- nose.
 - lungs.
 - air sacs.
 - trachea.
28. The following are plant nutrients. Which one is a macro-nutrient?
- Molybdenum.
 - Boron.
 - Iron.
 - Phosphorus.
29. The jaws of herbivores have a toothless gap called diastema that helps in
- tearing food.
 - proper turning of food while chewing.
 - holding and gripping food.
 - chewing hard grains.
30. A child with wrinkled face, visible bones and cries a lot is also likely to
- have swollen limbs and face.
 - have sores at the corners of the mouth.
 - have thin brownish skin.
 - have pot bellied stomach.

31. The diagram below represents a set up that was used to demonstrate a certain process.

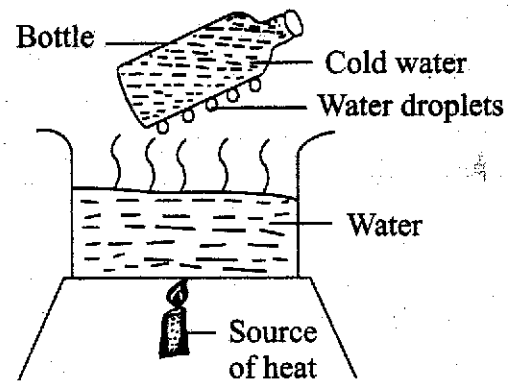

The process investigated was

- evaporation.
 - freezing.
 - convection.
 - condensation.
32. Animals are given commercial feeds for all the following reasons **except**
- some are given as the only food.
 - they are given mainly to increase production.
 - some are given together with other feeds.
 - they are mainly for protection against diseases.
33. Which pair of drugs below consists of **only** prohibited drugs in Kenya?
- Bhang and khat.
 - Tobacco and Alcohol.
 - Cocaine and cobbler's glue.
 - Mandrax and miraa.

34. During the process of making food in plants
- A. chemical energy is converted to light energy.
 - B. solar energy is converted to chemical energy.
 - C. light energy is converted to green energy.
 - D. photosynthesis energy is converted to green energy.

35. Mulching is done to crops for all the following reasons **except** to
- A. conserve soil moisture.
 - B. form organic manure after decomposition.
 - C. control the growth of weeds.
 - D. control pests in crops.

36. The diagram below was set up by std. 6 pupils.

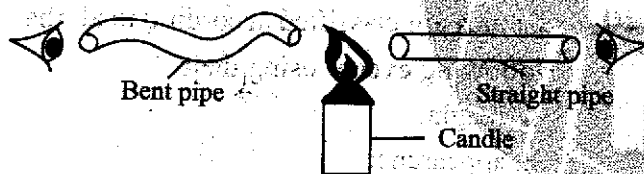

The aspect of light being investigated was

- A. formation of shadows.
 - B. reflection of light.
 - C. how light travels in a straight line.
 - D. how light travels at angles.
37. The blood vessel that receives blood from all parts of the body to the heart has the following characteristics **except**
- A. have a wide lumen.
 - B. have valves.
 - C. blood flows under pulse.
 - D. have thin inelastic walls.

38. Which one of the following materials will be attracted by a magnet?
- A. Office pins and copper coin.
 - B. Staples and hacksaw blade.
 - C. Steel wool and aluminium plate.
 - D. Silver coin and iron nail.

39. A papyrus plant has all the following characteristic **except**
- A. it has shallow root system.
 - B. it has wide broad leaves.
 - C. it has thick waxy cuticles on leaves.
 - D. it has air sacs on the leaves.

40. Which pair of animals below can be grouped together in a food chain?
- A. Lions and zebras.
 - B. Snakes and mice.
 - C. Antelopes and mice.
 - D. Hyenas and gazelles.

41. The following are common features between a frog and a lizard **except**
- A. both have external fertilization.
 - B. both lay eggs.
 - C. both breathe by means of lungs.
 - D. both have varying body temperature.

42. The statements below are all correct about simple machines **except** one. Which one is it?
- A. Simple machines make work easier by increasing effort or force applied.
 - B. They make work easier by increasing the speed of working.
 - C. They make work easier by changing the direction of force.
 - D. They make work easier by reducing the amount of work done.

43. The diagram below represents a set-up used to investigate conditions necessary for germination.

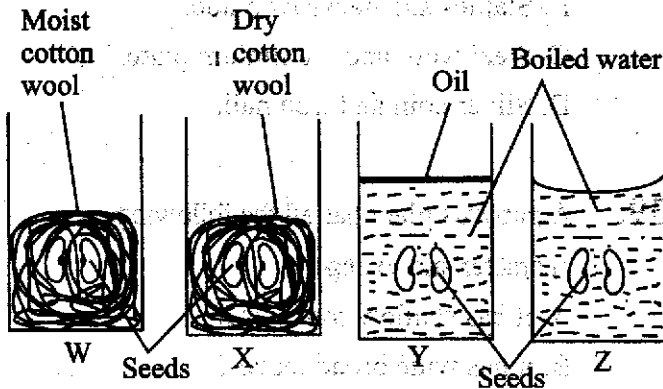

In which of the above set-ups did the seeds germinate?

- A. W, Y and Z
 B. W and Z
 C. X and Y
 D. Z and X
44. The following will cause water pollution **except** one. Which one is it?
 A. Acid rain.
 B. Smoke from industries.
 C. Oil spills.
 D. Uncontrolled use of farm chemicals.
45. The following are disadvantages of fertilizers **except** one. Which one is it?
 A. Are bulky to transport.
 B. Pollute environment if used in excess.
 C. Are expensive to buy.
 D. Can only be used for one growing season.

46. The largest planet in the solar system is
 A. Saturn.
 B. Earth.
 C. Jupiter.
 D. Neptune.

47. Which part of the air is used by leguminous plants to make nitrates that plants use to make proteins?
 A. Oxygen.
 B. Carbon dioxide.
 C. Nitrogen.
 D. Rare gases.

48. A newly formed cell after fertilization is known as
 A. an embryo.
 B. a foetus.
 C. an infant.
 D. a zygote.

49. Clouds are classified according to all the following **except** using their
 A. height.
 B. appearance.
 C. shape.
 D. weight.

50. All the following materials are needed when making a simple electric circuit. Which one is **not** needed?
 A. Dry cells.
 B. Connecting wires.
 C. Bulb.
 D. Sockets.

SECTION II
CHRISTIAN RELIGIOUS EDUCATION

61. God sent Adam and Eve out of the garden of Eden because
A. they had eaten fruits in the garden.
B. they failed to obey God's instructions.
C. they had become equal to God.
D. they had spoken to the snake.
62. *"Have many children so that your descendants will live all over the earth"* (Genesis 9:1). God said these words to
A. Noah after the flood.
B. Adam when he created him.
C. Eve when he brought her to Adam.
D. Abraham when he called him in Haran.
63. Jacob and his family went to live in Egypt because
A. there was not enough land in Canaan.
B. God had told Jacob to go to Egypt.
C. Joseph had invited them.
D. the king of Egypt wanted slaves.
64. When the Israelites travelled in the desert during the exodus they were led by
A. an angel.
B. a rainbow.
C. smoke.
D. a cloud.
65. From the story of Gideon and the Midianites Christians learn to
A. trust in God.
B. love their enemies.
C. help the needy.
D. be honest in their actions.
66. From whom did the Israelites demand for a king?
A. Joshua.
B. Samuel.
C. Eli.
D. Saul.
67. King Solomon turned away from God when he
A. allowed the worship of false Gods.
B. acquired a lot of wealth.
C. built a temple in Jerusalem.
D. traded with foreign kings.
68. Which prophet did God send to King David after he took Uriah's wife?
A. Ahijah.
B. Shemaiah.
C. Nathan.
D. Zadok.
69. From the raising of the son of the woman of Shunem Christians learn to
A. give thanks to God.
B. respect the laws of the country.
C. go to other lands to preach.
D. have faith in God.
70. Which one of the following events took place when Jesus was forty days old?
A. Temptation.
B. Dedication.
C. Naming.
D. Baptism.
71. Angel Gabriel appeared to Zechariah when he was
A. burning incense.
B. praying.
C. sleeping.
D. preaching.
72. The baptism of Jesus was important because
A. other people were being baptised.
B. he was fulfilling the wishes of the Jews.
C. he was about to start his work.
D. John was baptising people in River Jordan.
73. Which one of the following teachings did Jesus teach during the sermon on the mountain?
A. The true vine.
B. The way to the father.
C. Who is the greatest.
D. Love your enemies.
74. From the teaching of Jesus on who is the greatest, Christians learn that they should
A. humble themselves.
B. speak good of other Christians.
C. care for the poor.
D. treat other people well.

75. The parable of the lamp under a bowl teaches Christians that they should
 A. have their houses well lit.
 B. set good examples in the society.
 C. defend themselves when attacked.
 D. avoid places that are dark.
76. When Jesus was tried before Pilate, Pilate's wife described Jesus as
 A. a king.
 B. humble.
 C. innocent.
 D. powerful.
77. Mary Magdalene recognized Jesus when he
 A. spoke to her.
 B. broke the bread.
 C. disappeared.
 D. prayed for her.
78. The disciples had met on the day of the Pentecost in
 A. Bethany.
 B. the garden of Gethsemane.
 C. Jerusalem.
 D. Emmaus.
79. Who among the following people was among the seven helpers chosen to give food to the widows?
 A. Timothy.
 B. Timon.
 C. Titus.
 D. Thomas.
80. The escape of Paul from jail in Philippi teaches Christians
 A. to obey the laws of the country.
 B. that God protects his people.
 C. that some actions are illegal.
 D. to respect their leaders.
81. The gift of the Holy Spirit seen in Peter when he visited Joppa was
 A. wisdom.
 B. preaching.
 C. prophecy.
 D. working miracles.
82. When people mention names of ancestors in traditional African societies it shows that
 A. ancestors are worshipped.
 B. ancestors live with God.
 C. ancestors link the living to God.
 D. ancestors can hear people praying.
83. Which one of the following beliefs about God in traditional African societies is true?
 A. God lives in high places.
 B. God is the provider.
 C. God is trinity.
 D. God is worshipped through Jesus.
84. When people get good harvest in traditional African societies they thank God by
 A. giving food to the poor.
 B. giving foods for dowry.
 C. sharing meals with neighbours.
 D. offering food sacrifices in shrines.
85. According to the traditional African customs marriage is mainly meant for
 A. procreation.
 B. companionship.
 C. prestige.
 D. getting wealth.
86. Christians show their obedience to the laws of the country by
 A. going to church.
 B. paying taxes.
 C. donating food to refugees.
 D. attending funeral services.
87. What should Mary and James discuss when going home after school?
 A. When to marry after school.
 B. The bad things done by other classmates.
 C. How to make money during weekends.
 D. How to improve their marks.
88. Christians participate in tree planting in order to
 A. get rewards.
 B. avoid being arrested.
 C. care for the environment.
 D. join other people in tree planting.
89. Christians strengthen their faith when they
 A. study the Bible at home.
 B. give money to the needy.
 C. meet together and pray.
 D. get good education.
90. The first European missionaries came to Kenya and started a church at
 A. Rabai near Mombasa.
 B. Mbooni in Makueni.
 C. Maseno in Kisumu.
 D. Kabaa in Machakos.

SECTION II
ISLAMIC RELIGIOUS EDUCATION

61. Which one of the following surahs of the Quran encourages the belief in one God?
A. *Falaq*.
B. *Nas*.
C. *Maun*.
D. *Ikhlas*.
62. "Did He not make their plot go astray" The above quotation is a verse from surah
A. *Fiil*.
B. *Quraish*.
C. *Zilzala*.
D. *Asr*.
63. Which one of the following surahs is known as 'Ummul-Quran'?
A. *Masad*.
B. *Inshirah*.
C. *Ikhlas*.
D. *Fatiha*.
64. Which one of the following surahs narrates the events that took place the year the prophet (S.A.W) was born?
A. *Quraish*.
B. *Fiil*.
C. *Fatiha*.
D. *Qaria*.
65. Which one of the following verses is from surah Al-Kauthar?
A. "Verily man is at loss".
B. "You alone we worship and seek for help".
C. "Turn to your lord for prayer and sacrifice".
D. "Woe unto every slanderer and backbiter".
66. Which one of the following is not a teaching of the prophet concerning toileting?
A. *Entering the toilet with the left foot*.
B. *Not talking while in the toilet*.
C. *Coming out with the left foot*.
D. *Squatting while relieving yourself*.
67. According to the hadith of the prophet (S.A.W), a generous man is near Allah, near men, near paradise and far from
A. *relatives*.
B. *hell*.
C. *reality*.
D. *punishment*.
68. Which one of the following is not a sign of a hypocrite according to the hadith of the prophet?
A. *Lying*.
B. *Betraying trust*.
C. *Not fulfilling a promise*.
D. *Backbiting*.
69. Which one of the following is the first pillar of Islam?
A. *Kalima*.
B. *Zakat*.
C. *Salat*.
D. *Saum*.
70. How many parts are washed during the performance of udhu?
A. *Four*.
B. *Three*.
C. *Seven*.
D. *Six*.
71. Three of the following acts can nullify udhu. Which one cannot?
A. *Sleeping*.
B. *Excessive bleeding*.
C. *Breaking wind*.
D. *Laughing loudly*.
72. The act of going round the kaabah seven times during hajj is known as
A. *Arafat*.
B. *Sa'ay*.
C. *Tawaaf*.
D. *Miqat*.
73. How many categories of recipients of zakat are mentioned in the Quran?
A. *Eight*.
B. *Nine*.
C. *Seven*.
D. *Three*.
74. Which one of the following is the duty of angel Izrail?
A. *Recording our deeds*.
B. *Bringing rain*.
C. *Blowing the trumpet*.
D. *Taking souls from human beings*.
75. Who among the following was the king during the reign of prophet Ibrahim (a.s)?
A. *Jalut*.
B. *Namrud*.
C. *Firaun*.
D. *Najash*.

76. What was the name of the wife of prophet Adam (a.s)?
 A. Ruqaya.
 B. Maryam.
 C. Hawa.
 D. Amina.
77. How many rakaat are said during swalatul-maghrib?
 A. Four.
 B. One.
 C. Two.
 D. Three.
78. What should a Muslim say after completing a task?
 A. Alhamdulillah.
 B. Subhanallah.
 C. Maashallah.
 D. Bismillah.
79. Maryam found her mother with her friends in the house after school. What should she do?
 A. Ask the mother what the visitors are doing.
 B. Greet the visitors with respect.
 C. Ask the visitors to leave.
 D. Remain outside and play.
80. The best way of helping orphans is by
 A. taking them to an orphanage.
 B. employing them.
 C. taking them to school.
 D. giving them some money.
81. The Suhuf were revealed to prophet
 A. Adam.
 B. Musa.
 C. Daud.
 D. Ibrahim.
82. The best wedding according to the traditions of the prophet is the one done in the
 A. playground.
 B. school hall.
 C. mosque.
 D. home.
83. Who among the following was the first wife of prophet Mohammad (S.A.W)?
 A. Aisha.
 B. Zainab.
 C. Sauda.
 D. Khadijah.
84. Which one of the following terms means extravagance?
 A. Israaf.
 B. Ghush.
 C. Ihtikar.
 D. Usury.
85. The prophet (S.A.W) was born on
 A. 10th Dhul-hijjah.
 B. 12th Rabiul-Awwal.
 C. 27th Rajab.
 D. 1st Shawwal.
86. Where did the prophet (SAW) used to meet the Muslims during the earlier period of Islam?
 A. In cave Hirah.
 B. In cave Thaur.
 C. In the house of Nadwa.
 D. In the house of Arqam.
87. Which of the following battle was Hamza martyred?
 A. Badr.
 B. Khandaq.
 C. Uhud.
 D. Hunain.
88. Who among the following was the first woman to accept Islam?
 A. Maryam.
 B. Hawa.
 C. Sumayya.
 D. Khadijah.
89. Who helped prophet Suleiman during the construction of Masjidul-Aqsa?
 A. Other prophets.
 B. Angels.
 C. Jinns.
 D. Mysterious animals.
90. How long did the treaty of Hudaibiya last?
 A. 10 years
 B. 2 years
 C. 8 years
 D. 11 years

Umepewa dakika 40 kuandika insha yako.

Andika insha isiyopungua ukurasa mmoja na nusu ukifuata maagizo uliyopewa: Andika insha itakayomalizika kwa maneno haya:

.....Niliamini kuwa akufaaye kwa dhiki ndiye rafiki.

You have 40 minutes to write your composition.

The following is the beginning of a composition. Complete it in your own words making it as interesting as possible.

I could see clouds of thick black smoke rising from a distance as I was busy playing with my friends. I



TARGETETER
004

YEAR 2016

MARKING SCHEME

MATHS	ENGLISH	KISWAHILI	SCIENCE	S/STUDIES/R.E	
1. B	1. C	1. B	1. D	1. B	51. A
2. C	2. B	2. C	2. D	2. D	52. C
3. D	3. D	3. A	3. D	3. C	53. D
4. A	4. A	4. C	4. C	4. A	54. A
5. C	5. B	5. B	5. C	5. B	55. B
6. D	6. C	6. D	6. B	6. A	56. D
7. A	7. D	7. A	7. C	7. D	57. A
8. B	8. A	8. C	8. B	8. B	58. A
9. C	9. B	9. A	9. B	9. C	59. D
10. A	10. C	10. D	10. C	10. A	60. C
11. B	11. D	11. B	11. D	11. D	
12. A	12. A	12. C	12. C	12. A	<u>C.R.E</u>
13. A	13. A	13. A	13. B	13. C	70. C
14. D	14. D	14. D	14. C	14. B	71. D
15. C	15. B	15. C	15. B	15. A	72. C
16. D	16. A	16. D	16. D	16. A	73. A
17. D	17. B	17. C	17. C	17. D	74. D
18. B	18. A	18. B	18. C	18. D	75. B
19. C	19. D	19. C	19. D	19. A	76. C
20. B	20. C	20. D	20. A	20. B	77. D
21. D	21. D	21. A	21. B	21. C	78. A
22. A	22. D	22. C	22. C	22. A	79. B
23. B	23. A	23. D	23. D	23. C	80. B
24. D	24. A	24. C	24. C	24. D	81. D
25. B	25. D	25. D	25. B	25. C	82. C
26. B	26. A	26. A	26. C	26. B	83. D
27. C	27. A	27. B	27. A	27. A	84. A
28. A	28. D	28. D	28. D	27. A	85. B
29. A	29. C	29. C	29. B	28. D	86. D
30. D	30. D	30. B	30. D	29. C	87. C
31. B	31. A	31. B	31. D	30. A	88. D
32. C	32. B	32. C	32. D	31. B	89. C
33. B	33. C	33. D	33. C	32. D	90. B
34. C	34. D	34. A	34. B	33. C	
35. C	35. C	35. B	35. D	34. B	
36. D	36. A	36. A	36. C	35. C	
37. D	37. C	37. B	37. C	36. D	
38. C	38. D	38. C	38. B	37. A	
39. B	39. C	39. D	39. C	38. B	
40. A	40. D	40. C	40. C	39. D	
41. B	41. B	41. D	41. A	40. B	
42. A	42. D	42. A	42. D	41. C	
43. B	43. B	43. B	43. B	42. A	
44. D	44. A	44. C	44. B	43. B	
45. B	45. B	45. B	45. A	44. C	
46. C	46. D	46. A	46. C	45. D	
47. D	47. C	47. C	47. C	46. B	
48. B	48. B	48. B	48. D	47. A	
49. D	49. D	49. A	49. D	48. C	
50. C	50. C	50. B	50. D	49. B	
				50. D	

Book for the next code 005, Email: info@targeteterpublishers.co.ke Nairobi

N.B: Please, teachers are requested to scrutinize this marking scheme before use. It is worth.