



# HIGH PERFORMANCE EXAM SERIES

## STANDARD THREE

### YEAR 2016

# [3]

# ENGLISH

NAME: \_\_\_\_\_ SCHOOL: \_\_\_\_\_ DATE: \_\_\_\_\_

### Fill in the gaps with the correct word

We need trees to 1. They are good for many things. When it is day time, they make our land look 2. When it is 3, we sit under a tree. Trees give us shade. At night, trees clean the 4 we breathe 5. Trees hold the soil in place. They make the 6 fall from the 7. 8 make their homes on trees and 9 sweet songs in them. Animals can live in trees 10.

{live, green, air, hot, rain, in, Birds, sky, too, sing}

### Complete the comparison

- 11. Big, bigger, \_\_\_\_\_
- 12. Fast, faster, \_\_\_\_\_
- 13. Strong, stronger, \_\_\_\_\_
- 14. Thin, thinner, \_\_\_\_\_

### Write the past tense

- 15. Sleep - \_\_\_\_\_
- 16. Carry - \_\_\_\_\_

- 17. Cry - \_\_\_\_\_
- 18. Sit - \_\_\_\_\_
- 19. Laugh - \_\_\_\_\_
- 20. Smile - \_\_\_\_\_

### Name the pictures below

21.

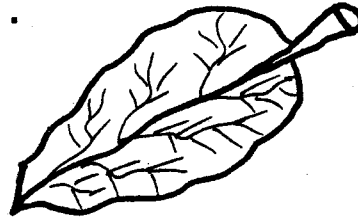

\_\_\_\_\_

22.



\_\_\_\_\_

23.

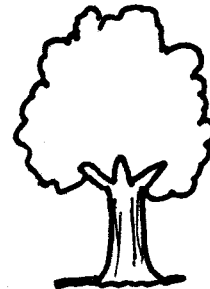

\_\_\_\_\_

**Write the young ones of the following animals**

- 24. Elephant - \_\_\_\_\_
- 25. Lion - \_\_\_\_\_
- 26. Goat - \_\_\_\_\_
- 27. Cow - \_\_\_\_\_
- 28. Dog - \_\_\_\_\_

(calf, puppy, kid, calf, cub)

**Use "are", "am" or "is"**

- 29. They \_\_\_\_\_ boys.
- 30. They \_\_\_\_\_ playing.
- 31. He \_\_\_\_\_ a boy.
- 32. I \_\_\_\_\_ walking.
- 33. That \_\_\_\_\_ a tree.

**Add '-ing'**

- 34. Laugh - \_\_\_\_\_
- 35. Carry - \_\_\_\_\_
- 36. Sleep - \_\_\_\_\_
- 37. Read - \_\_\_\_\_
- 38. Sit - \_\_\_\_\_
- 39. Write - \_\_\_\_\_

**Find the missing end word to make one word**

- 40. Wheel - \_\_\_\_\_
- 41. Head - \_\_\_\_\_
- 42. Black - \_\_\_\_\_
- 43. Class - \_\_\_\_\_
- 44. Cup - \_\_\_\_\_
- 45. Shop - \_\_\_\_\_

(master, keeper, board, room, borrow, board)

**Read the passage below and answer questions 46 - 50**

John and Jerry swim in the lake. They are having fun but then the rain falls. Drop, drop, drop, drop. Mother does not let them swim in the rain. They must go home. They start to run fast. John slips and falls. He hurts his foot.

He gets on his knees and cries, "Wait for me. A nail has pricked my foot."

"Where are your shoes?" Jerry asked. "I don't have any," John says. Jerry holds him. They walk home slowly.

- 46. What was the names of the two boys? \_\_\_\_\_
- 47. John and Jerry like \_\_\_\_\_
- 48. What pricked John's leg? \_\_\_\_\_
- 49. Who helped John? \_\_\_\_\_
- 50. The two boys walk home \_\_\_\_\_



# HIGH PERFORMANCE EXAM SERIES

## STANDARD THREE

YEAR 2016

[3]

### READING & KUSOMA

NAME: \_\_\_\_\_

SCHOOL: \_\_\_\_\_

DATE: \_\_\_\_\_

## READING

### Read these words

- |                  |             |              |               |
|------------------|-------------|--------------|---------------|
| 1. Town          | 6. Firewood | 11. Seedling | 16. Beautiful |
| 2. Carpenter     | 7. Announce | 12. Text     | 17. Accident  |
| 3. Duster        | 8. Humble   | 13. Circle   | 18. Traffic   |
| 4. Entertainment | 9. Ladder   | 14. Stamp    | 19. Envelope  |
| 5. Calculate     | 10. Typist  | 15. Bowl     | 20. Engine    |

### Read these sentences

21. He is a rude boy.
22. It was a horrific accident.
23. Do not kill the giraffe.
24. Tom and Mary are tourists.
25. We didn't know he was a thief.

## KUSOMA

### Soma majina haya

- |             |              |             |              |
|-------------|--------------|-------------|--------------|
| 1. Lugha    | 6. Popote    | 11. Kombe   | 16. Sonara   |
| 2. Uwezo    | 7. Ufafanuzi | 12. Mfano   | 17. Kisigino |
| 3. Malkia   | 8. Hongera   | 13. Nidhamu | 18. Mieleka  |
| 4. Soksi    | 9. Sakafu    | 14. Ng'ambo | 19. Bawabu   |
| 5. Tetemeko | 10. Asante   | 15. Ukurasa | 20. Shikamoo |

### Soma sentensi hizi

21. Nilipata mwaliko wako.
22. Bwana Ouma ni mvuvi wa samaki.
23. Kazi hii ni ngumu lakini yapendeza.
24. Si vizuri kunywa mvinyo ovyo ovyo.
25. Gurudumu la gari limeibwa.



# HIGH PERFORMANCE EXAM SERIES

## DARASA LA TATU

### MWAKA 2016

**[3]**  
**KISWAHILI**

JINA \_\_\_\_\_

SHULE: \_\_\_\_\_

TAREHE: \_\_\_\_\_

**Andika sehemu za mnyama huyu**

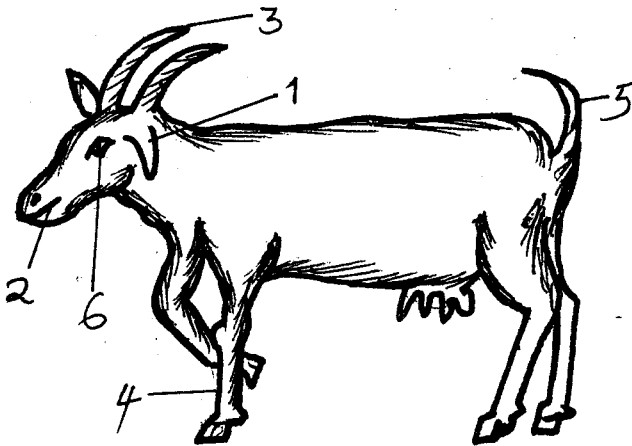

1. \_\_\_\_\_
2. \_\_\_\_\_
3. \_\_\_\_\_
4. \_\_\_\_\_
5. \_\_\_\_\_
6. \_\_\_\_\_

(Mkia, Jicho, Mguu, Mdomo, Pembe, Sikio)

**Andika kwa wingi**

7. Karatasi - \_\_\_\_\_
8. Choo - \_\_\_\_\_
9. Ukuta - \_\_\_\_\_
10. Kitabu - \_\_\_\_\_

**Jaza pengo ukitumia "mbele ya", "kati ya", "nyuma ya" au "ndani ya"**

11. Si vizuri kusimama \_\_\_\_\_ ya gari.
12. Mwalimu mkuu husimama \_\_\_\_\_ darasa anapofundisha.
13. Maji yako \_\_\_\_\_ chupa,
14. Shilingi imeanguka \_\_\_\_\_ shimo

**Andika majina ya maumbo haya**

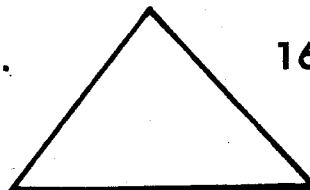
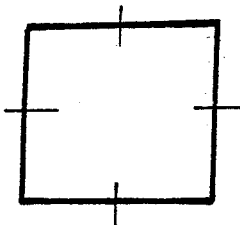
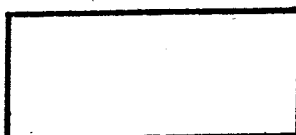
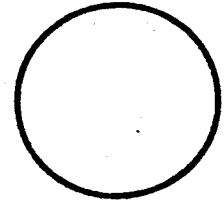
15.  \_\_\_\_\_
16.  \_\_\_\_\_
17.  \_\_\_\_\_
18.  \_\_\_\_\_

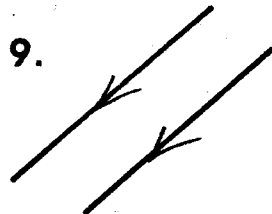
19.  \_\_\_\_\_

(Pembe tatu, Mistari sambamba, Mstatili, mviringo, Mraba)

**Andika kinyume**

20. Jioni - \_\_\_\_\_

21. Lala - \_\_\_\_\_

**Andika majina haya vizuri**

22. rasada - \_\_\_\_\_

23. wakinja - \_\_\_\_\_

**Chagua neno lisilofaa kwenye kikundi**

24. Chungwa, ndizi, meza, embe  
\_\_\_\_\_

25. Kitabu, mbolea, mimea, udongo  
\_\_\_\_\_

**Andika tarakimu kwa maneno**

26. 70 \_\_\_\_\_

27. 30 \_\_\_\_\_

28. 16 \_\_\_\_\_

29. 93 \_\_\_\_\_

30. 40 \_\_\_\_\_

**Kamilisha methali**

31. Mkono mtupu \_\_\_\_\_

32. Mkono mmoja hauchinji \_\_\_\_\_

(ng'ombe, haulambwi)

**Tumia silabi hizi kuunda maneno**

**Mfano: Ka - Kaka**

33. ba - \_\_\_\_\_

34. ko - \_\_\_\_\_

35. cha - \_\_\_\_\_

36. gha - \_\_\_\_\_

37. fa - \_\_\_\_\_

**Kanusha**

38. Anapika - \_\_\_\_\_

39. Soma - \_\_\_\_\_

40. Cheza - \_\_\_\_\_

**Kamilisha sentensi zifuatazo**

41. \_\_\_\_\_ hutaga mayai.

42. Nyanya analima kwa kutumia  
\_\_\_\_\_

43. Mamba huishi wapi? \_\_\_\_\_

44. Ng'ombe hutupa \_\_\_\_\_

45. Chakula hupikiwa \_\_\_\_\_

(Jikoni, majini, nyama, jembe, kuku)

**Soma kifungu kifuatacho kisha ujibu maswali 46 - 50**

Ajali nyingi hutokea barabarani. Hii ni kwa sababu barabara zetu ni mbovu mno kiasi cha kuwashinda dereva wetu kuendesha vizuri. Dereva wengine si watu waangalifu wanapoendesha magari ya abiria. Wengine hata huwa walevi

46. Ajali hutokea wapi? \_\_\_\_\_

47. Barabara zetu huwa \_\_\_\_\_  
(mbovu, bofu)

48. Nani huendesha magari?  
\_\_\_\_\_

49. Mtu mlevi huwa amekunywa nini? \_\_\_\_\_

50. Kifungu hiki kinazungumza juu ya nini? \_\_\_\_\_



# HIGH PERFORMANCE EXAM SERIES

## STANDARD THREE

### YEAR 2016

# [3]

# SCIENCE

NAME: \_\_\_\_\_



SCHOOL: \_\_\_\_\_

DATE: \_\_\_\_\_

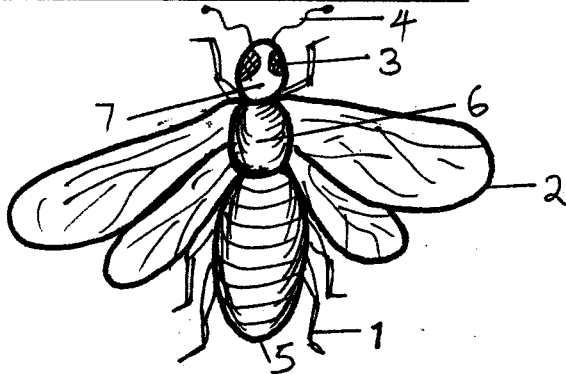
### Name the parts of the insect

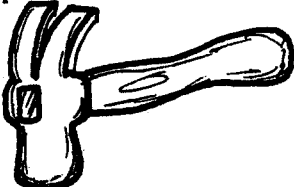

1. \_\_\_\_\_
2. \_\_\_\_\_
3. \_\_\_\_\_
4. \_\_\_\_\_
5. \_\_\_\_\_
6. \_\_\_\_\_
7. \_\_\_\_\_
8. Weather can be recorded using \_\_\_\_\_ (letters, symbols, charts)
9. Which insect spreads Malaria? \_\_\_\_\_ (Spider, Housefly, Mosquito)
10. Heavy rainfall causes \_\_\_\_\_ (famine, thirst, floods)
11. Cactus plant grows in \_\_\_\_\_ areas (dry, wet, cool)
12. We have \_\_\_\_\_ senses. (four, three, five)
13. A doctor who treats sick animals is called \_\_\_\_\_ (an optician, a veterinary, a nurse)

14. The best soil for farming is \_\_\_\_\_ (loam, sand, clay)
15. Mangoes, apples and oranges are examples of \_\_\_\_\_ (fruits, seeds, vegetables)
16.  This is a \_\_\_\_\_ (panga, jembe, hammer)
17.  This is a \_\_\_\_\_ leaf (maize, bean, wheat)
18. A \_\_\_\_\_ has no legs. (snake, bat, hen)
19. Reflected sound is called \_\_\_\_\_ (light, echo, energy)
20. A \_\_\_\_\_ changes its colour. (chameleon, cockroach, snake)
21. The main source of light is \_\_\_\_\_ (stars, moon, sun)
22. People with eyes problem wear \_\_\_\_\_ (clothes, bandages, spectacles)
23. We plant crops during \_\_\_\_\_ season. (rainy, sunny, windy)
24. Handkerchiefs are used to clean our \_\_\_\_\_ (noses, mouth, legs)
25. Ripe tomatoes are \_\_\_\_\_ in colour. (green, red, black)

26. Rubbish should be kept in a \_\_\_\_\_  
(latrine, dish, dust bin)

27.  This balloon is filled with \_\_\_\_\_  
(water, soil, air)

28. We should wash our hands \_\_\_\_\_  
visiting the toilet.  
(before, after, during)

Name the parts of a fish

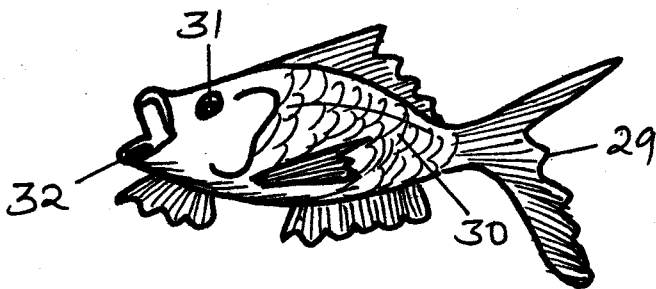

29. \_\_\_\_\_

30. \_\_\_\_\_

31. \_\_\_\_\_

32. \_\_\_\_\_

33.  This plant is called \_\_\_\_\_  
(tree, cactus, sisal)

Name the parts of a bird

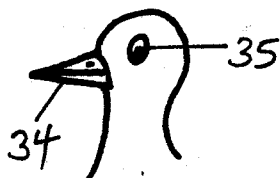

34. \_\_\_\_\_

35. \_\_\_\_\_

36. When things vibrate they produce \_\_\_\_\_  
(light, noise, sound)

37. When we look at the mirror, we see our \_\_\_\_\_  
(picture, image, shadow)

38. \_\_\_\_\_ helps us to chew food.  
(Tongue, Teeth, Nose)

39.  This is a \_\_\_\_\_  
(comb, funnel, jug)

40. Trees give us \_\_\_\_\_  
(shade, diseases, metal)

41. All living things need \_\_\_\_\_ to grow.  
(light, food, air)

42. We can use a \_\_\_\_\_ to carry goods.  
(donkey, dog, cat)

43. \_\_\_\_\_ can be eaten raw.  
(Pumpkins, Maize, Carrots)

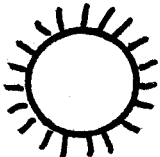
44.  The weather is \_\_\_\_\_

45. A \_\_\_\_\_ treats our teeth.  
(nurse, veterinary, dentist)

46.  This pot is made using \_\_\_\_\_ soil.  
(sand, clay, loam)

47. People who can't talk are called \_\_\_\_\_  
(deaf, dumb, blind)

48. The body of a snake is covered with \_\_\_\_\_  
(scales, feathers, skin)

49. A mango fruit has \_\_\_\_\_ seeds  
(two, one, many)

50. A \_\_\_\_\_ feeds on grass only.  
(cat, lion, zebra)



# HIGH PERFORMANCE EXAM SERIES

## STANDARD THREE

YEAR 2016

[3]

### SOCIAL STUDIES & C.R.E

NAME: \_\_\_\_\_

SCHOOL: \_\_\_\_\_

DATE: \_\_\_\_\_

#### NZURI AREA

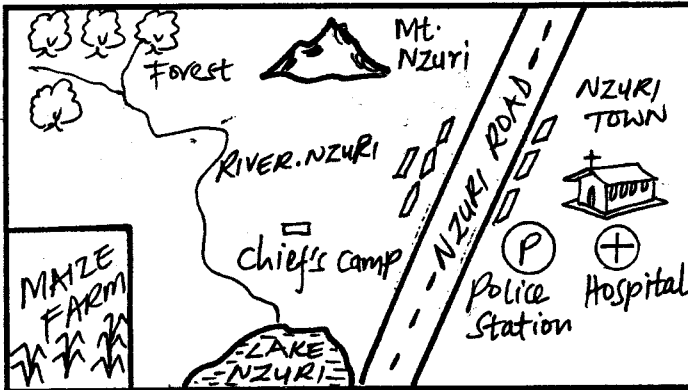

1. The main crop grown in Nzuri area is \_\_\_\_\_ (maize, beans, tea)
2. Name the mountain in Nzuri area \_\_\_\_\_
3. People in Nzuri area are \_\_\_\_\_ (Christians, Muslims, Pagans)
4. Name the river in Nzuri area \_\_\_\_\_
5. The lake in Nzuri area is called \_\_\_\_\_
6. Who arrests law breakers in Nzuri area? \_\_\_\_\_
7. River Nzuri starts from the \_\_\_\_\_ (mountain, town, forest)
8. The basic needs are food, shelter and \_\_\_\_\_ (clothing, car, TV)
9. Rivers which flow during the rainy season only are called \_\_\_\_\_ rivers. (permanent, seasonal, rain)
10. Among the following, which is the most expensive method of transport? \_\_\_\_\_ (Air, Roads, Water)

11. Which one is the main source of water in your area? \_\_\_\_\_

12. The head of the family is \_\_\_\_\_ (father, mother, uncle)

#### Name three cash crops

13. \_\_\_\_\_

14. \_\_\_\_\_

15. \_\_\_\_\_

16.  This type of house is called \_\_\_\_\_ (hut, manyatta, cave)

17. The sun sets in which direction? \_\_\_\_\_ (East, North, West)

18. Among the following communities, which one keeps a large herd of cattle? \_\_\_\_\_ (Maasai, Agikuyu, Luo)

19. People living near lakes and oceans practice \_\_\_\_\_ (farming, mining, fishing)

#### Use the diagram below to answer questions 20 - 22



20. This animal is called \_\_\_\_\_ (sheep, cow, goat)



21. The animal above gives us \_\_\_\_\_ and \_\_\_\_\_

22. \_\_\_\_\_

Name the following physical features

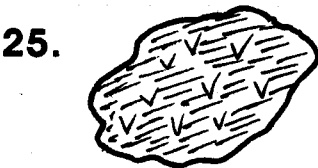

\_\_\_\_\_ (swamp, river, hill)

26. The capital city of Kenya is \_\_\_\_\_ (Kisumu, Nairobi, Mombasa)

27. Who is the President of Kenya? \_\_\_\_\_ (Daniel Moi, William Ruto, Uhuru Kenyatta)

Name the following means of communication

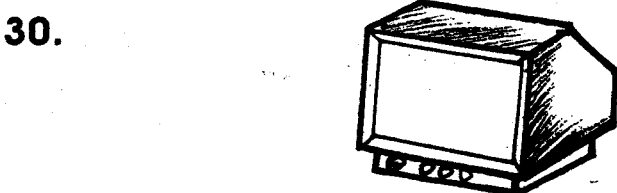
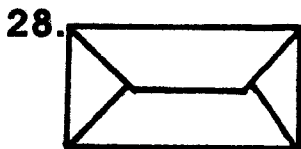

\_\_\_\_\_ (Television, Mobile phone, Letters)

C.R.E

31. Jesus had \_\_\_\_\_ disciples. (10, 12, 6)

32. Jacob had \_\_\_\_\_ sons. (2, 4, 12)

33. \_\_\_\_\_ was the wife of Isaac. (Rachel, Leah, Rebecca)

34. God rested on the \_\_\_\_\_ day. (sixth, seventh, fourth)

Name three disciples of Jesus

35. \_\_\_\_\_

36. \_\_\_\_\_

37. \_\_\_\_\_

38. The father of Jesus was a \_\_\_\_\_ (carpenter, mason, priest)

39. Jesus was born in \_\_\_\_\_ (Bethlehem, Golgotha, Eden)

40. We should \_\_\_\_\_ our enemies (love, kill, sell)

41. Christians should \_\_\_\_\_ God. (hate, obey, ignore)

42. Jesus was crucified with \_\_\_\_\_ thieves. (two, three, four)

43. King Ahab killed \_\_\_\_\_ (Naboth, David, Saul)

44. \_\_\_\_\_ was David's loyal friend. (Saul, Solomon, Jonathan)

45. \_\_\_\_\_ betrayed Jesus. (Peter, Judas, Pilate)

46. Lazarus' sisters were Mary and \_\_\_\_\_ (Jane, Martha, Ruth)

47. Jesus was buried in a \_\_\_\_\_ (cross, tomb, cave)

48. Abraham's son was called \_\_\_\_\_ (David, Isaac, Jacob)

49. \_\_\_\_\_ was sold by his brothers in Egypt. (John, Joseph)

50. \_\_\_\_\_ works in the temple. (Plumbers, Carpenters, Priests)



# HIGH PERFORMANCE EXAM SERIES

## STANDARD THREE

### YEAR 2016

# [3]

## MATHEMATICS

NAME: \_\_\_\_\_

SCHOOL: \_\_\_\_\_

DATE: \_\_\_\_\_

1.  $100 + 92 + 32 =$  \_\_\_\_\_

2.  $99 + 23 + 2 =$  \_\_\_\_\_

3. 
$$\begin{array}{r} 220 \\ - 92 \\ \hline \end{array}$$

4. 
$$\begin{array}{r} 236 \\ - 31 \\ \hline \end{array}$$

5. 
$$\begin{array}{r} 329 \\ + 321 \\ \hline \end{array}$$

**Add**

6.  $\frac{1}{2} + \frac{1}{2} =$  \_\_\_\_\_

7.  $\frac{1}{4} + \frac{1}{4} =$  \_\_\_\_\_

8.  $\frac{1}{8} + \frac{2}{8} =$  \_\_\_\_\_

9.  $\frac{2}{6} + \frac{1}{6} =$  \_\_\_\_\_

10.  $42 \div 6 =$  \_\_\_\_\_

11.  $48 \div 8 =$  \_\_\_\_\_

12.  $36 \div 4 =$  \_\_\_\_\_

13.  $3 \times 13 =$  \_\_\_\_\_

14. \_\_\_\_\_  $\div 5 = 4$

15.  $5 \times$  \_\_\_\_\_  $= 30$

16. Sh. 10 = \_\_\_\_\_ 50 cts coins

17.  $604 =$  \_\_\_\_\_ hundreds \_\_\_\_\_ tens  
\_\_\_\_\_ ones

**Write in numbers or words**

18.  $49 =$  \_\_\_\_\_

19.  $26 =$  \_\_\_\_\_

20. Three hundred and four = \_\_\_\_\_

21. 1 week = \_\_\_\_\_ days.

22. 1 month = \_\_\_\_\_ weeks

23. 1 year = \_\_\_\_\_ months

24. 1 day = \_\_\_\_\_ hours

25. Arrange the numbers from the smallest to the largest.

110, 106, 112, 101, 192, 102, 182,

\_\_\_\_\_

26. What is  $\frac{1}{9}$  of 18? \_\_\_\_\_

27.  $\frac{1}{10}$  of 20 = \_\_\_\_\_

28.  $\frac{1}{2}$  of 2 = \_\_\_\_\_

29. 
$$\begin{array}{r} \text{Sh.} \quad \text{cts} \\ 20 \quad 10 \\ + 22 \quad 16 \\ \hline \end{array}$$

30. 
$$\begin{array}{r} \text{Sh.} \\ 22 \\ -16 \\ \hline \end{array} \quad \begin{array}{r} \text{cts} \\ 10 \\ 05 \\ \hline \end{array}$$

31. 
$$\begin{array}{r} \text{m} \\ 5 \\ +16 \\ \hline \end{array} \quad \begin{array}{r} \text{cm} \\ 8 \\ 10 \\ \hline \end{array}$$

32. 
$$\begin{array}{r} \text{m} \\ 29 \\ +19 \\ \hline \end{array} \quad \begin{array}{r} \text{cm} \\ 30 \\ 10 \\ \hline \end{array}$$

**What fraction is unshaded**

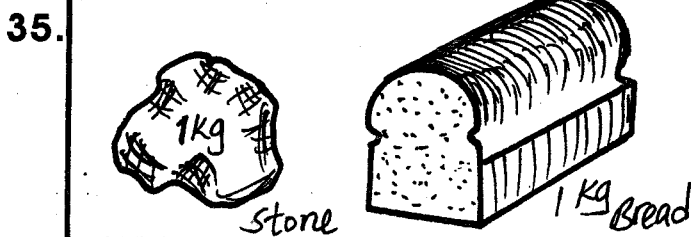
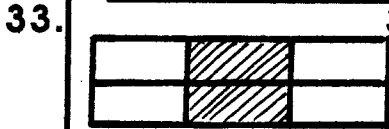

Which one is heavier? \_\_\_\_\_

36. How many days are there in the months of March and April? \_\_\_\_\_

37.  $1783 - 546 =$  \_\_\_\_\_

38. How many days are there in 3 weeks? \_\_\_\_\_

39. How many weeks are there in 5 months? \_\_\_\_\_

**Use the shopping list below to answer questions 40 - 42**

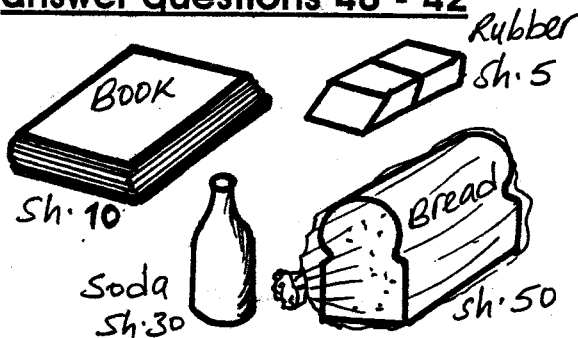

40. Ali bought a book, a rubber and soda. How much did he pay?  
\_\_\_\_\_

41. I bought a loaf of bread and 2 sodas. How much did I pay?  
\_\_\_\_\_

42. My sister bought a book and a rubber. How much did she pay?  
\_\_\_\_\_

**Name the shapes**

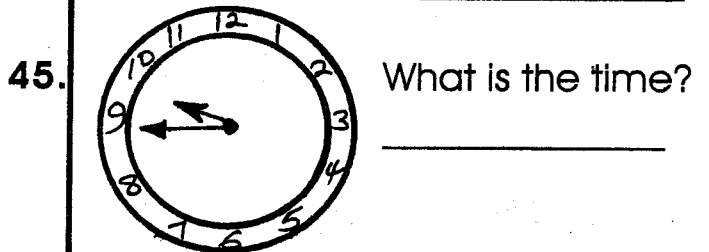
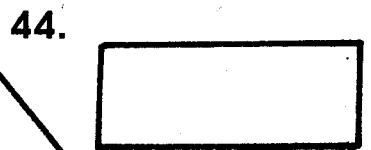
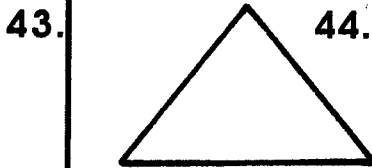

**Use the diagram below to answer questions 46 - 48**

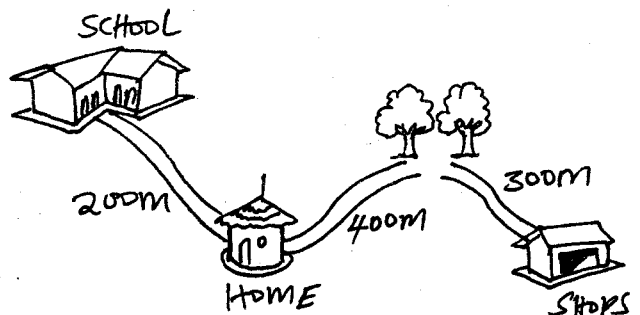

46. Tom walked from school to the shops. What distance did he cover? \_\_\_\_\_

47. What is the distance from the forest to the school? \_\_\_\_\_

48. What is the distance from the forest to home? \_\_\_\_\_

49. What is the number after 99? \_\_\_\_\_

50. How many triangles can you see?  
\_\_\_\_\_