

STEGA SERIES

STANDARD EIGHT 2015

SOCIAL STUDIES

Time: 2 hours :15 Min

Study the map of Fedha area and answer questions 1 - 7

FEDHA AREA

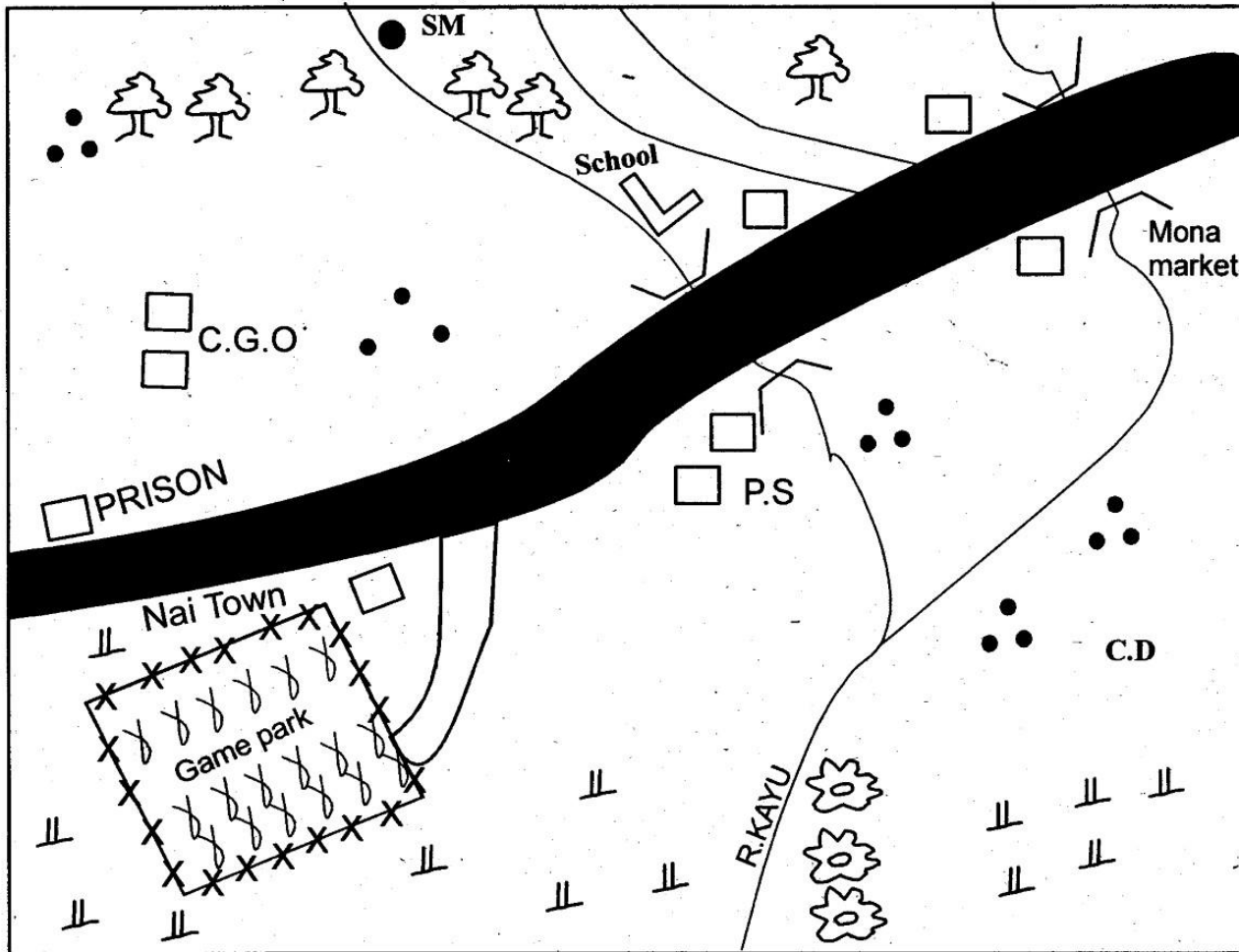

Scale

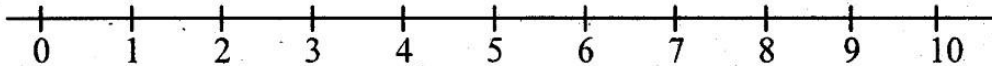

KEY

- | | | | |
|-------------------|--|--------------------------|-------|
| Tarmac road | | Grass | |
| Murram road | | Sand pits | |
| Electric fence | | Saw mill | SM |
| Build-up areas | | Cattle dip | C.D |
| Human settlements | | Police station | P.S |
| Planted trees | | County Government office | C.G.O |

- Market?
- A. North East B. South East
C. North West D. South West
2. Mona Market is located where it is mainly due to the presence of a _____
A. river B. road junction
C. high population D. fertile land
3. The settlement in Fedha area can be described as _____
A. Linear B. Clustered
C. Sparse D. Dense
4. The land in fedha area generally slopes from _____
A. North B. West
C. East D. South
5. All the following are economic activities in Fedha area except _____
A. Mining B. Pastoralism
C. Lumbering D. Fishing
6. The chief administrator in Fedha area is likely to be _____
A. Governor B. Senator
C. President D. Judge
7. A thief is caught stealing in Nai Town. He should first be taken to _____
A. Governor's office B. Prison
C. Police station D. Game park wardens
8. The main duty of the Kenya Police is to _____
A. prosecute law breakers.
B. maintain law and order.
C. investigate crime.
D. protect public properties.
9. A river that ends in many streams at the mouth forms a _____
A. seasonal river B. delta
C. Estuary D. confluence
10. After their migration Bantus settled at Shungwaya. They then left Shungwaya because they were attacked by _____
A. Diseases B. Galla
C. Dorobo D. Arabs
11. The secretary of the school committee is _____
A. chairperson B. Headteacher
C. Deputy headteacher D. prefect

air mainly because _____

- A. It is most expensive
B. It is the most comfortable way
C. It is very fast
D. There is no traffic jam.
13. Which one of the following reasons led to the fall of the Old Ghana kingdom?
A. poor weapons
B. because of the trade
C. Attack by the enemies
D. Lack of unity
14. Three of the following instruments are kept in Stevenson's screen except _____
A. Thermometer B. Barometer
C. Anemometer D. Hygrometer
15. Jinja and Thika towns have one thing in common. This is;
A. both are counties
B. both are industrial centres
C. both are agricultural centres
D. both have many vehicles
16. The main mineral exported from Nigeria is likely to be _____
A. Petroleum B. copper
C. Gold D. Limestone
17. The main problem facing tourism in Kenya is _____
A. poaching
B. Insecurity
C. High taxes
D. Lack of accomodation facilities

Use the map below to answer questions 18-21

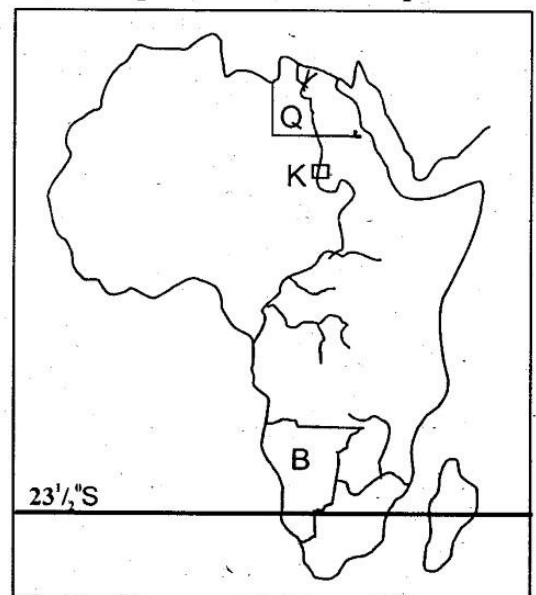

18. The main reason for the establishment of the River project marked **K** is _____
 A. water for irrigation
 B. production of H.E.P
 C. to control flood
 D. provide water for fishing
19. The country marked **Q** attained independence in the year _____
 A. 1963
 B. 1946
 C. 1922
 D. 1979
20. The country marked **B** was colonized by _____
 A. British
 B. Germany
 C. Italians
 D. Spanish
21. The sun is overhead the latitude $23\frac{1}{2}^{\circ}\text{S}$ in the month of _____
 A. June
 B. September
 C. March
 D. December
22. Human beings endanger lives of living things in water when they _____
 A. Release harmful chemicals into water sources.
 B. Release smoke into the atmosphere.
 C. Are located near rivers.
 D. Use water to process products.
23. The main problem facing settlement in Lambwe Valley in Kenya is _____
 A. frequent flooding
 B. lack of rainfall
 C. presence of Tsetse flies
 D. insecurity
24. The main factor to consider when locating a bakery factory is availability of: _____
 A. Raw materials
 B. Market
 C. Source of power
 D. other industries
25. Who among the following people led the Nandi to resist the British colonial rule?
 A. Masaku
 B. Mekatilili wa Menza
 C. Koitalel Arap Samoei
 D. Leibon Lenana
26. The main crop grown in Kakira Irrigation Scheme is _____
 A. sugarcane
 B. rice
 C. sisal
 D. cotton

27. Below are factors about a certain town.
 (i) Main industrial centre in Tanzania.
 (ii) Largest trading centre.
 (iii) Major tourist centre.
 (iv) Residential centre.

The town described above is _____

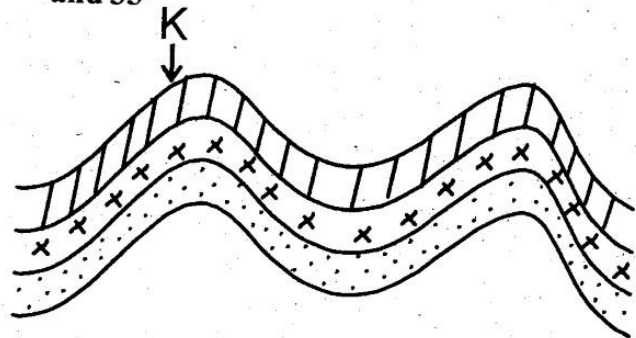
- A. Dar-es-salaam
 B. Dodoma
 C. Arusha
 D. Mologolo
28. Growing of trees together with crops is known as _____
 A. Defforestation
 B. Agro-forestry
 C. Reafforestation
 D. Agro-chemical
29. Which one of the following communities was among the long distance traders?
 A. Baganda
 B. Agikuyu
 C. Nyamwezi
 D. Abawanga
30. The major problem affecting pastoralism in Kenya is _____
 A. Insecurity
 B. cattle theft
 C. prolonged drought
 D. pests and diseases
31. Which of the following is the odd one out?
 A. Ruwenzoris
 B. Pare
 C. Kilimanjaro
 D. Usambara
32. Customary marriages are conducted by _____
 A. elders
 B. civil servants
 C. parents
 D. clerics
33. Providing social amenities to family members is the responsibility of _____
 A. All family members
 B. parents
 C. children
 D. servants
- Use the diagram below to answer questions 34 and 35
- 
34. Which one of the following features was formed through the process shown above?
 A. Mt. Kenya
 B. Mt. Dankil Alps
 C. The Cape ranges
 D. The Rift valley
35. The area marked **K** are known as _____
 A. Anticlines
 B. Escarpment
 C. Synclines
 D. Faults

36. Which one of the following is not the responsibility of the Deputy headteacher?
 A. The secretary to the staff.
 B. The Head of the disciplinary panel in school.
 C. Chairs the school committee meetings.
 D. Prepares the school block Timetable.
37. Camphor, Meru-oak, Mvule and Mahogany are all examples of _____
 A. Hardwood trees
 B. Softwood trees
 C. Evergreen trees
 D. Planted trees only
38. Falasha are Semites speakers in which Eastern African country?
 A. Somalia
 B. Ethiopia
 C. Eritrea
 D. Sudan
39. The main tourist attraction in Egypt is _____
 A. Gedi ruins
 B. Koobi Fora
 C. Pyramids
 D. Robben's island
40. Great Ustu Forests in African are found in _____
 A. Gabon
 B. D.R.C
 C. Zimbabwe
 D. Swaziland
41. A clan is made up of people related by _____
 A. marriage
 B. language
 C. blood
 D. colour
42. The person who is elected to represent the county in the house of National Assembly is _____
 A. Woman representative
 B. MPs
 C. Governors
 D. Senators
43. The early visitor who discovered the source of River Nile in Uganda was _____
 A. John Speke
 B. Ronald Mcdonald
 C. David Livingstone
 D. Edward Johns
44. Marble, a mineral mined at Kerio valley is mined through _____
 A. scooping
 B. open cast
 C. Drilling
 D. Dredging
45. An example of an ox bow lake in Eastern Africa is lake _____
 A. Kanyaboli
 B. Masinga
 C. Paradise
 D. Tana
46. The capital city of cape verde is _____
 A. Moroni
 B. Praia

C. Bamako
 D. Luada

47. The main function of Njuri Ncheke among the Ameru is _____
 A. Teaching the youths
 B. Leading the community in war.
 C. Solving disputes among the people.
 D. leading in trading activities
48. The most convinient method of sending information to many people within a very short time is by _
 A. phone
 B. radio
 C. Television
 D. Fax
49. Soda ash is mainly transported through railway for exportation because _____
 A. It is the fastest means
 B. It is easy to access
 C. Soda ash is bulky
 D. It is an order from the government.

Use the diagram below to answer questions 50 and 51

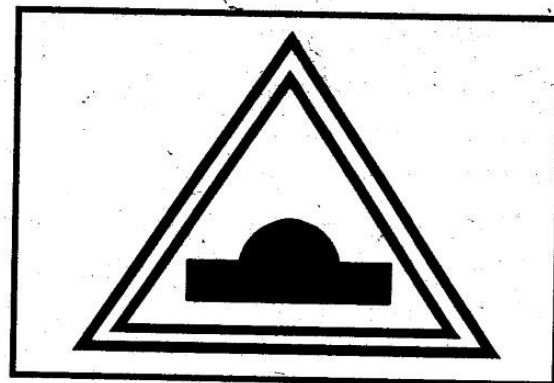

50. The road sign shown above informs motorists that they are approaching _____
 A. Road bumps
 B. a bridge
 C. a sharp corner
 D. a school
51. This road sign can most likely be found in areas where the road _____
 A. Is narrow
 B. Is not tarmacked
 C. Has potholes
 D. Road passes a crowded area.
52. Who among the following was the greatest African poet?
 A. Jomo Kenyatta
 B. Julius Nyerere
 C. Sedar Senghar
 D. Kamzu Banda
53. A school motto is written to enable pupils mainly to _____

- A. achieve the aims of a school
 B. pass their school tests
 C. win inter-school competition
 D. Respect their teachers.
54. In Kenya, a person is allowed to vote after attaining the age of _____
 A. 21 years B. 35 years
 C. 18 years D. 30 years
55. The paper manufacturing industry in Kenya is located at _____
 A. Kisumu B. Webuye
 C. Nakuru D. Homabay
56. Who among the following is not a member of cabinet in Kenya?
 A. President B. Cabinet Secretary
 C. Speaker D. Attorney General
57. Which one of the following is a non-food processing industry?
 A. leather industry B. bread making
 C. tea packing D. pineapple canning
58. Which one of the following is the ruling party in Tanzania?
 A. TANU B. UTP
 C. CCM D. TPP
59. Parliamentary proceedings are recorded in _____
 A. Mace B. Standing orders
 C. Hansard D. Manifesto
60. The county governor is elected by the _____
 A. County Assembly members
 B. The senators
 C. Voters in the county
 D. Members of the county Executive

C.R.E

61. When God created the universe the earth was _____
 A. full of light
 B. full of God's creation
 C. organised and formless
 D. formless and desolate
62. What did God create during the 3rd day?
 A. sea and dry land B. sky
 C. heavenly bodies D. fish and birds
63. Elijah challenged the Baal prophets at Mount _____
 A. Horeb B. Moriah
 C. Carmel D. Sinai
64. God appeared to Moses when he was grazing the

- flock at _____
 A. Egypt B. Midian
 C. Horeb D. Shiloh
65. Israelites complained of bitter water at _____
 A. Massah B. Marrah
 C. Gilboa D. Moab
66. Who among the following was the first murderer in the Bible?
 A. Saul B. Moses
 C. Samuel D. Cain
67. Who was the only woman judge in Israel?
 A. Deborah B. Rahab
 C. Lyddia D. Mary
68. Both Jesus and Elisha performed a miracle of _____
 A. multiplying oil and flour
 B. raising sons of widows
 C. healing lepers
 D. walking on water
69. Who among the following kings of Israel brought the ark of covenant in the temple?
 A. David B. Solomon
 C. Ahab D. Saul
70. Which is the only prophetic book in the New testament?
 A. Luke B. Acts
 C. Jude D. Revelation
71. Who prophesied the birth place of Jesus?
 A. Jeremiah B. Micah
 C. Isaiah D. Hosea
72. Who among the following kings wanted to kill Jesus?
 A. Herod B. Pilate
 C. Caiphas D. Anas
73. Which one of the following parables teaches about the value of the kingdom of God?
 A. mustard seed B. pearl
 C. lost coin D. lost son
74. The Ethiopian Eunuch was reading a verse from the book of _____
 A. Ezekiel B. Acts
 C. Joel D. Isaiah
75. "Happy are the merciful"
 A. They will obtain mercy.
 B. They will see God
 C. They will be comforted
 D. They will be satisfied fully
76. Jesus was circumcised and given the name Jesus

- when he was _____ old.
- A. 40 days B. 12years
C. 8 days D. 8 years
77. Which one of the following miracles is found in the four gospel books?
A. cursing the fig tree
B. raising of Lazarus
C. feeding 4,000 people
D. feeding 5,000 people
78. Who among the following gave a tomb for Jesus to be buried? _____
A. Simon the Zealot
B. Joseph of Arimathea
C. Simon of Cyrene
D. Cleophas and his friends
79. Who was chosen and blessed by all the apostles to help them distribute food and money to the widows?
A. Deacons B. priests
C. clergy D. laity
80. When the disciples received the holy spirit, who gave a speech and many people became christians?
A. Paul B. Peter
C. John D. Jesus
81. Baptism in christianity is compared to _____ in African traditional society.
A. polygamy B. miscarriage
C. initiation D. Pouring libation
82. In African traditional society, youths after initiation were required to be very _____.
A. brave B. smart
C. obedient D. responsible
83. In christianity people marry mainly _____.
A. to become elders
B. to become wealthy
C. to get children
D. for companionship
84. In African traditional society people reconciled with God mainly through _____.
A. pouring libation
B. offering animal sacrifices
C. naming children after the ancestors
D. calling out their names
85. Three of the following are forms of sexual misuse EXCEPT: _____
- A. Hugging B. Incest
C. Fornication D. Bestiality
86. Erick a standard 7 boy is found in a group of smokers. As a christian what is the best thing for you to do?
A. Join them and continue smoking
B. Call the police immediately
C. Report him to his mother
C. Tell him the dangers of smoking
87. Mr. Mwangi a farm manager employed people of his own tribe. This vice is called _____.
A. Nepotism B. Greed
C. Racism D. Tribalism
88. Jane a standard 8 girl is pregnant. As a christian what can you advise Jane to do?
A. Give birth and continue with education
B. Ask her how she feels to be pregnant
C. Carry out abortion
D. Run away from home and get married.
89. Which one of the following is the best way a christian can use leisure?
A. Reading christian novels
B. Watching christian novels
C. Cleaning the compound
D. Visiting a home of the elderly.
90. The main reason that led missionaries to come to Kenya was to _____.
A. Build mission schools
B. Teach Africans on how to read and write
C. Preach the gospel.
D. Stop slave trade.

STEGA SERIES

DARASA LA NANE 2015

KISWAHILI

MUDA: 1: DAKIKA 40

Jaza mianya kwa kuchagua jibu sahihi

_____ 1 _____ za Kiafrika ni _____ 2 _____ na zinafaa _____ 3 _____ . Nyingi _____ 4 _____
maadili heshima na umoja wa _____ 5 _____ . _____ 6 _____ elimu vitabu imeendelea kuzua changamoto
_____ 7 _____ zinatishia kuziangamiza kabisa. _____ 8 _____ jambo la kawaida _____ 9 _____ watu kuziona mila
na desturi zao _____ 10 _____ mambo zamani.

- | | | | | | |
|-----|----------------|-----------------|---------------|---|------------------|
| 1. | A. Tamaduni | B. utamaduni | C. hali | S | D. mambo |
| 2. | A. mzuri | B. dhahimu | C. kali | | D. bora |
| 3. | A. Kundunishwa | B. Kuandimishwa | C. kudumishwa | | D. kuachwa |
| 4. | A. hutimiza | B. huhimiza | C. huongeza | | D. hukaribisha |
| 5. | A. jamaa | B. utaifa | C. jamii | | D. makundi |
| 6. | A. Hivyo basi | B. Hata hivyo | C. Vilevile | | D. Halikadhalika |
| 7. | A. ambo | B. ambayo | C. ambacho | | D. ambazo |
| 8. | A. Limekuwa | B. imekuwa | C. Umekuwa | | D. Wamekuwa |
| 9. | A. ha | B. katika | C. baina | | D. kwa |
| 10. | A. zilikuwa | B. zikiwa | C. zikawa | | D. ikakuwa |

Watu wengi pia _____ 11 _____ tamaduni hizi kama _____ 12 _____ wa maendeleo. _____ 13 _____ kwamba
inawezekana mtu kupata elimu na vilevile kudumisha mila na maadili yetu. Wazazi _____ 14 _____ hawawafunzi
watoto wao lugha _____ 15 _____ mama, huwafunza kiingereza tu.

- | | | | | | |
|-----|---------------|------------------|---------------|--|----------------|
| 11. | A. wanachukua | B. zinachukuliwa | C. huchukulia | | D. huchukuliwa |
| 12. | A. kukosa | B. ukosefu | C. kukosana | | D. kukosea |
| 13. | A. Hawakujua | B. Walielewa | C. Hawatajua | | D. Hawajui |
| 14. | A. wengi | B. kwingi | C. mingi | | D. wote |
| 15. | A. ya | B. wa | C. cha | | D. za |

Chagua jibu sahihi kulingana na maagizo

16. Kitezi kutokana na nomino sanaa ni _____
A. sana B. sanifu
C. usanii D. usanifu
17. Mingapi itakatwa kesho? Neno lililopigwa kistari ni mfano wa _____
A. kivumishi kiulizi B. kiwakilishi kiulizi
C. kielezi idadi D. kiwakilishi sifa
18. Chagua sentensi iliyo katika kauli ya kutendea.
A. mzee amejawa na usingizi
B. kisu hakishikiki vyema
C. mtoto amemkimbilia baba yake
D. nilikuita ukanyamaza
19. Kamilisha kwa kutumia kiunganishi sahihi.
_____ niliondoka mapema nilichelewa kufika shuleni kwa wakati.
A. isipokuwa B. ijapokuwa
C. mradi D. kwa maana
20. Eleza maana ya : Ngingekuona ningekuita.
A. Sikukuona na kwa hivyo sikukuita
B. Sikukuona lakini nilikuita
C. Nilikuona lakini sikukuita
D. Nilikuita ukanyamaza
21. Mweke ni rafiki _____ dhati.
A. yangu wa B. wangu ya
C. wangu wa D. yangu ya
22. Yakinisha sentensi hii. Usipomshika sikio hatanyooka.
A. Ulimshika sikio akanyooka
B. Utakapomshika sikio atanyooka
C. Umshike sikio anyooke
D. Ukimshika sikio atanyooka
23. Taja matumizi ya kwa katika sentensi hii.
Walikuja kwa harusi.
A. Uhusiano wa watu wa mahali

- B. kielezi
C. madhumuni
D. kuonyesha sehemu
24. Bainisha 'ji' katika sentensi hii. Uogeleaji wake ulivutia
A. utendaji B. ukubwa
C. mtendaji D. nafsi
25. Methali ipi inayohimiza uvumilivu.
A. Jifya moja haliinjiki chungu
B. Yote yang' aayo si dhahabu
C. Cha kuzama hakina ruhani
D. Umemla ng'ombe mzima usishindwe na mkia
26. Jaza mapengo vilivyo, Mwuzaji huyu alilipa _____
Kwa mkopo alioutumia kama _____ kuanzisha biashara yake.
A. Fidi/mtaji B. Ridhaa/fidia
C. Riba/tijari D. Riba/duhuli
27. Udogo wa wingi. 'Mlima huu si mrefu' ni _____
A. lima hili si refu
B. vilima hivi si virefu
C. milima hii si mirefu
D. vilima hivi ni virefu
28. Ni sentensi ipi sahihi?
A. Mwanafunzi mwenye anasoma ana bidii
B. Mwanafunzi mwenye anayesoma ana bidii
C. Mwanafunzi ambaye anayesoma ana bidii
D. Mwanafunzi ambaye anasoma ana bidii.
29. Orodha ipi inaonyesha viingizi pekee?
A. Abe!, Lahaula!, Kumbe!, Lo!
B. Lo!, Ihali!, Kumbe!, Lahaula!
C. Kumbe!, Lau!, Aka!, Po!
D. Aka!, Lo!, Hario!, Ebo!
30. Ni upi ufupisho wa 'mwana wetu?'
A. mwanetu B. mwanaetu
C. mwanayetu D. mwanawetu

Soma kifungu kifuatacho kisha ujibu maswali 31-40

Matukio yaliyofuata baada ya Wakenya wapatao 100 kufariki kwa kunywa pombe iliyokuwa na sumu kali, yanatoa mafunzo mengi kwa wazalendo wa nchi hii. Hata hivyo, inasikitisha kwamba wakenya ni wepesi wa kurushiana lawama badala ya kuzingatia wanayojifunza kutokana na mikasa na hii huibua shaka ikiwa kuna wazalendo dhati katika nchi hii.

Inasikitisha kuona kwamba mtu anaweza kutengeneza pombe iliyo na sumu kali na kuisambaza maeneo kadhaa nchini akiwa na lengo la kuua watu wasio na hatia. Hiki bila shaka ni kitendo cha kikatili kinachonyesha kwamba hakuna wazalendo wa kweli katika nchi hii. Haya yalidhihirika baada ya uchunguzi kuonyesha kwamba pombe iliyoua watu katika kaunti kadhaa ilikuwa na kiwango kikumbwa cha sumu aina ya 'Methanol' iliyofanya walionusurika kuwa vipofu.

Pombe hiyo haikutengenezwa maeneo iliyoua watu, bali iliuzwa na wafanyabiashara waliokuwa na leseni na ilikuwa na nembo ya kuonyesha kwamba iliidhinishwa na idara zinazohusika. Ingawa simtetei yeyote, ninaamini kwamba Wakenya wote tunastahili lawama.

Kwa maoni yangu Waziri wa usalama wa ndani hakufaa kuwasimamisha kazi maafisa 52 wa utawala wa mkoa na usalama kwa kushindwa kuzuia pombe hiyo kuuzwa katika maeneo hayo.

Alichopasa kufanya ni kuwaandama waliotengeneza pombe hiyo na kuchukulia hatua haswa maafisa waliotengeneza pombe hiyo na kuwachukulia hatua haswa maafisa walioshindwa katika kazi yao ya kuhakisha ubora wa pombe hiyo. Lakini kama ilivyo kawaida ya Wakenya, watu waliotaka kujiondolea lawama, walimshauri waziri kuwasimamisha kazi maafisa ambao hawakuweza kufanya lolote kuzuia wafanyabiashara kuuza pombe.

Sio mara ya kwanza kwa mkasa kama huu kutokea na hatua ya kwanza inapaswa kuwa uchunguzi wa kina, bila pupa ilikupata chanzo cha tatizo hili ndipo liweze kutatuliwa kikamilifu. Kwa kuchukua hatua za haraka ili kujiondolea lawama kama ilivyoshuhudiwa katika maafisi na idara tofauti zinazohusika, hakutaweza kusuluhisha tatizo hili bali ni kufungua milango kwa wahalifu waliohusika kuficha vitendo vyao.

31. Baada ya watu mia kuangamizwa na pombe haramu
 A. Taifa limekomesha ulevi.
 B. Hapana tena ugemaji wa pombe.
 C. Wengi wamejifunza mengi kote nchini.
 D. Ulevi umezidi hata baada ya maafa.
32. Kulingana na aya ya pili
 A. Wakenya hukubali makosa yao
 B. Wakenya daima huwalaumu wenzao
 C. Baadhi ya wakenya ni waadili
 D. Wakenya tangu wakati hujilaumu
33. Mwandishi anashuku kama kuna wazalendo wa dhati katika nchi hii kwa sababu ya _____
 A. Kuweko kwa mikasa inayoletwa na wakenya
 B. Wakenya kutokubali makosa yao
 C. Wakenya kuwalaumu wenzao
 D. Wakenya kuwalaumu serikali
34. Lengo hasa la uuzaji wa pombe yenye sumu ni _____
 A. kuwauwa watu
 B. kujipatia pesa
 C. kusababisha vurugu nchini
 D. kuwataja wazalendo
35. Ni kweli kusema _____
 A. wagemaji pombe haramu wana viwanda kote nchini.
 B. msemaji pombe huwa mmoja, na husambaza bidhaa yake.
 C. viwanda vya 'Methanol' vimejaa kote.
 D. pombe zote huwa na methanol ila kwa kiwango cha chini.
36. Kabla bidhaa haijauzwa, ni lazima
 A. itengenezewe katika sehemu fulani
 B. kikubalike na wakenya wote wazalendo
 C. ipewe leseni na idara zote za serikali
 D. ipewe leseni na idara husika
37. Kutokana na vifo hivi
 A. Maafisa wa usalama walimwaga unga
 B. waziri alisimamishwa kazi
 C. Biashara zote zilifungwa
 D. maafisa kadhaa wa usalama walisimamishwa kazi.
38. Ili kumaliza visa kama hivi ni muhimu
 A. kwa maafisa wa utawala kuwajibika
 B. Raia kuacha kutumia pombe zenye sumu
 C. kuwaatia mbaroni wanaozitengeneza pombe hizi
 D. kuwanyima leseni za ufanyibiashara wagemaji wote
39. Uchunguzi wa kina ni
 A. utafiti maalum kuhusu pombe hizi
 B. utafiti wa pombe hizi
 C. utafiti wa muda mrefu
 D. utafiti unaofanywa katika maabara
40. Kulingana na aya ya mwisho
 A. Tatizo hilo lilitatuliwa
 B. suluhisho la kudumu halikufikiwa
 C. wahalifu waliacha uhalifu wao
 D. idara husika ziliacha kulaumiana

Soma ufahamu kisha ujibu maswali 41-50.

Siku chache zimepita tangu Wakenya washuhudie onyesho la kipekee lililosimamiwa na Raisi Uhuru Kenyatta katika kaunti ya Mombasa. Onyesho hilo ililohusisha kulipuliwa kwa meli kwenye Bahari Hindi lilikuwa la kipekee kwani wengi hawajawahi kushuhudia tukio kama hilo. Ingawa hatua ile ilinuiwa kuwasilisha ujumbe kwa vigogo wa ulanguzi wa mihadarati, lazima serikali ikumbushwe kuwa hiyo haitoshi

Ulanguzi wa dawa za kulevya umekuwa donda sugu humu nchini kwa miaka mingi. Eneo la Pwani ambapo meli ililipuliwa pamoja na dawa zilizo naswa limekuwa likiongoza orodha ya maneno yanayoathiriwa zaidi na mihadarati humu nchini. Familia zimepoteza wapendwa wao kwa mkosi huu na wana wa watu wakavurugiwa maisha yao kutokana na matumizi ya vileo hivyo.

Wakati Gavana wa Mombasa alipoingia mamlakani mwaka jana, tulishudia akiongoza juhudi nyingi zilizosemekana zililenga kukabiliana na ulanguzi wa dawa za kulevya katika eneo hilo.

Jitihada hizo hatujui ziliishia wapi, kwani ilifika wakati ambapo haikuonekana kama chochote kilikuwa kinafanywa kuziendeleza zaidi. Hali hiyo iliendelea hadi wiki iliyopita ambapo Rais aliwasili Pwani akiwa na ujumbe sawa na ule uliotolewa na Gavana alipoingia mamlakani.

Vita dhidi ya mihadarati haviwezi kufanikishwa bila kutia nguvuni wahusika wakubwa walio kwenye biashara hiyo Ripoti mbalimbali za upelelezi kutoka mataifa ya magharibi huwa zimehusisha wanasiasa na wafanyabiashara wakubwa nchini na uovu huo. Haieleweki kwa nini serikali haijawahi kujizatiti kuchunguza watu wanaotajwa mara kwa mara kwenye ripoti hizo na kuwachukulia hatua za kisheria ipasavyo

Hatua zinazochukuliwa za kubomoa malicho ya watumizi wa mihadarati na kulipua meli zinazopatikana zikisafirisha dawa hizo zitakuwa sawa na mchezo wa tisha toto hadi itafikia wakati toto halitaitishika tena na litazidisha utundu wake Ukitaka kuangamiza magugu ni sharti ungo e mizizi yake, la sivyo yatazidi kukua.

Hii ni sawa na vita dhidi ya mihadarati, ambapo hakuna kitakachofanikiwa bila kukabili mabwanyenye wanaohusika na wanoaofaidi kutokana na uozo huu. Mmiliki wa meli huenda akawa si mlanguzi kibinafsi, na kuna uwezekano hata hakufahamu kilichokuwa kikisafirishwa kwenye meli yake. Lakini anafaa kutafutwa ili asaidie kwenye uchunguzi wa kubaini waliokodisha meli hiyo, kama ilikodishwa na washiriki wao waliotakiwa kupokea mzigo huo nchini.

Watakaopatikana kuhusika kwa njia yoyote ile waadhibiwe ipasavyo bila kujali ikiwa wana mamlaka makubwa serikalini au kiwango cha ushuru wanachochangia kwenye kapu la uchumi wa taifa. Kwa sasa, ni wazi kuwa hasara ya kibiashara na walanguzi hao. Watachukua hatua kwa njia wanayofahamu wenyewe na kuadhibu waliodhani walilegea kazini na kupelekea kifurushi chao kukamatwa. Hatimaye, biashara itaendelea kama kawaida na kama wafanyabiashara, wataweka mikakati kuhakikisha pengo lililoachwa na hasara iliyopatikana limejazwa haraka iwezekanavyo. Hii ni ikiwa hatua ya serikali ilikamilika tu kwa vitisho vya wiki jana.

- | | |
|--|--|
| <p>41. Wakenya walishuhudia tukio lisilo la kawaida kwani</p> <p>A. Lilikuwa baharini
B. meli ilikuwa imebeba mihadarati
C. lilihudhuriwa na raisi
D. halijawahi kutokea kama hilo</p> <p>42. Tukio hilo lilikuwa na kusudi gani?</p> <p>A. kumaliza biashara ya mihadarati
B. serikali haina huruma na walanguzi
C. meli yaweza kulipuliwa na kuzamishwa
D. mihadarati yote itazamishwa</p> <p>43. Serikali inatakiwa kufanya nini ili kudhibiti hali hii?</p> <p>A. kuwatia mbaroni walanguzi wenyewe
B. kutunga sheria kali kuhusu walanguzi
C. kuzamisha mihadarati pindi inapopatikana
D. polisi kulinda bandari yetu</p> <p>44. Ni kweli kusema kwamba</p> <p>A. eneo la Pwani ndilo la pekee lenye tatizo la mihadarati
B. mihadarati imeathiri sehemu yingi ingawa Pwani iko mstari wa mbele
C. mihadarati yote nchini hutoka eneo hii la Pwani
D. wakazi wote wa eneo hili ni walevi</p> <p>45. Juhudi za gavana wa eneo hili</p> <p>A. zilifua dafu kukabili tatizo hilo
B. zingali zinaendelea kupambana na mihadarati
C. zimekula mwande hadi sasa
D. zinakabiliwa na hitilafu</p> | <p>46. Ni nani wanaiendeleza biashara hili?</p> <p>A. viongozi wa kisiasa pekee
B. viongozi serikalini
C. wafanyibiashara wakubwa
D. wasafiri kutoka ng'ambo</p> <p>47. Je, wale wanaoshukiwa kuuza mihadarati wanajulikana?</p> <p>A. La
B. ndio
C. hawezi kujulikana
D. wasafiri kutoka ng'ambo</p> <p>48. Ni juhudi zipi za kukabiliana na mihadarati hazijafanywa?</p> <p>A. kuiharibu inapopatikana
B. kupeleleza wahusika wakuu
C. kubomoa maficho ya watumizi
D. kuwashtaki wahusika wakuu</p> <p>49. Mmiliki wa meli anawezaje kuisaida serikali?</p> <p>A. kuiielekeza kwa mwenye mizigo
B. kujua zilikokuwa zikielekeza bidhaa
C. kutoa habari kila chombo chake kinaposafirisha mihadarati
D. Kufidia hasara ya mizigo mingine katika meli</p> <p>50. Mwandishi anaelezea kuwa _____</p> <p>A. tukio hilo litakuwa na manufaa makubwa
B. tukio hilo halitazua biashara hii kuendelea
C. tukio hilo ni pigo kubwa sana kwa walanguzi wote
D. wafanyibiashara hii hawatakuwa na mbinu nyingine za kuiendeleza biashara yao.</p> |
|--|--|

STEGA SERIES

STANDARD EIGHT 2015

MATHEMATICS

Time: 2 hours

1. Which of the following numbers is one hundred and one million one hundred and one thousand and one.

- A. 101101001 B. 101100101
C. 1000100101 D. 10110010

2. What is the number 9.962 rounded off to one decimal place?

- A. 9.96 B. 10,000
C. 9,960 D. 10.0

3. What is the square of $4\frac{3}{5}$?

- A. $2\frac{3}{5}$ B. $16\frac{9}{25}$
C. $21\frac{4}{25}$ D. $8\frac{3}{5}$

4. What is the value of $7 + (1\frac{1}{2} - \frac{3}{4})$?

- A. $8\frac{1}{4}$ B. $7\frac{3}{4}$
C. $21\frac{4}{5}$ D. $9\frac{1}{2}$

5. What is the sum of the total value of digit 3 and 4 in the number 14369?

- A. 430 B. 3400
C. 4300 D. 34

6. What is the next number in the sequence? 1, 3, 6, 10

- A. 15 B. 21
C. 13 D. 16

7. What is the capacity of a container which measures 2.0 m by 1.5m by 0.5 m?

- A. 1.5 L B. 150 L
C. 1500 L D. 1500 L

8. Construct triangle ABC such that AB= 5 cm, BC= 6.5 cm and angle ABC = 50° . What is the measure of line AC?

- A. 6 cm B. 6.5
C. 7cm D. 5 cm

9. The table below shows the number of children born between 2000 and 2004

Year	2000	2001	2002	2003	2004
No of children	10002	21000	18003	24009	26001

In which year did the number of children least increase?

- A. 2000-2001 B. 2003-2004
C. 2001-2002 D. 2002-2003

10. In the figure below, AB, is parallel to CD while angle ECD = 55°

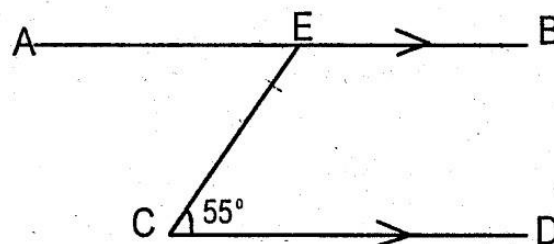

What is the size of angle CEB?

- A. 55° B. 180°
C. 25° D. 125°

11. A shopkeeper had the following amount of money in her cash box

Number of coins/notes	2	4	7	9	1
Value in shillings	20	40	50	100	1000

How much money did she have altogether?

- A. sh 2210 B. sh 2450
C. 1233 D. sh 19000

12. Simplify $\frac{5}{7}(7+14t) + \frac{2}{5}(5-15t)$

- A. $10t-6t-7$ B. $4t+7$
C. $4t+10$ D. $7-4t$

13. A newspaper vendor sold a total of 2000 copies at sh 40 each. If the vendor received a 10% commission, how much money did he receive from the sale?

- A. sh 8000 B. sh 7200
C. sh 80000 D. sh 72000

14. Construct triangle EFG such that angle EFG = 90° and EF = 4 cm and FG = 3 cm. Draw a circle that passes through the vertices EFG. What is the radius of the circle?
- A. 2.2 cm B. 3 cm
C. 2.5 cm D. 4 cm
15. Wanjiru spent sh 400 to buy 200 mangoes and then sold them making a profit of 25%. For how much did she sell the mangoes?
- A. sh 2.50 B. sh 2.00
C. sh 25.00 D. sh 14.00
16. In a trapezium, the two parallel sides are 24 cm and 16 cm long. The perpendicular distance between the parallel sides is 13 cm. What is the area of the trapezium?
- A. 520 cm^2 B. 260 cm^2
C. 130 cm^2 D. 60 cm^2
17. What is the value of $\frac{7.2 \times 0.35}{1.2}$?
- A. 21 B. 210
C. 2.1 D. 0.21
18. The scale 1:50000 can be written as _____
- A. 1 cm rep 500 km
B. 1 cm rep 500 m
C. 1 cm rep 50 km
D. 1 cm rep 50 m
19. In a meeting, $\frac{1}{4}$ of the attendants were boys while $\frac{1}{5}$ were girls. The rest were women. What fraction of the total attendants were women?
- A. $\frac{2}{9}$ B. $\frac{3}{9}$
C. $\frac{9}{20}$ D. $\frac{11}{20}$
20. Peter, Paul and Patrick shared sh 240. Patrick got a quarter while Paul got twice as much as Peter. How much money did Peter get?
- A. sh 60 B. sh 180
C. 120 D. sh 90
21. Wambui borrowed sh 300,000 from a bank that charged simple interest at the rate of 12% pa. How much should she pay the bank at the end of 6 months?
- A. sh 318000 B. sh 18000
C. sh 216000 D. sh 516000

22. What is the value of $\frac{4c}{c-d} + \frac{2a+b}{a-d}$?

If $a = 4$ $b = 0$ $c = 3$ $d = \frac{1}{2}a$

- A. 12 B. 16
C. 4 D. 8

23. An open cylindrical tin has a radius of 7 cm and a height of 15 cm. What is the surface area of the tin?

- A. 154 cm^2 B. 660 cm^2
C. 968 cm^2 D. 814 cm^2

24. The graph below shows how a cyclist travelled from town A to B. What was his average speed in km/hr

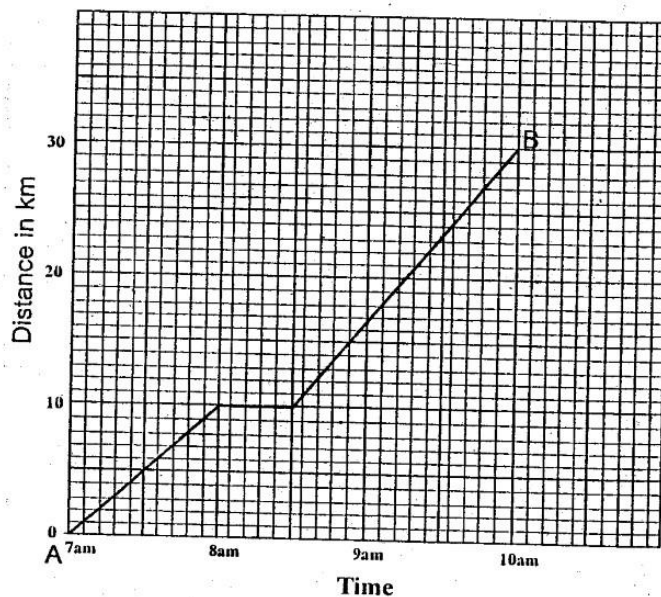

- A. 30 km/h B. 10 km/h
C. 300 km/hr D. 100 km/h

25. How many faces (F), Vertices (V) and edges (E) does a closed cube have

	F	V	E
A.	6	12	8
B	6	8	12
C	12	6	8
D	8	6	12

26. Mutiso left home at 10.45 and took 1 hr 30 min to travel to the market. He stayed in the market for 55 minutes and then travelled back home taking another $1\frac{1}{2}$ hr. At what time did he reach home?

- A. 2.40 pm B. 2.10 pm
C. 1.10 pm D. 1.45 pm

27. The mean height of six boys in a family is 151 cm. When their father's height is included, the mean height goes up by 2cm. What is the height of the father?

- A. 133cm B. 165cm
C. 153cm D. 175cm

28. Increase 60 by 20%

- A. 80 B. 48
C. 40 D. 72

29. In the figure below, $BE=EA=CE$. Angle $DBC=50^\circ$

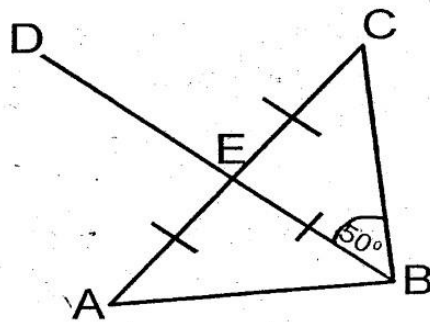

What is the measure of angle DEA?

- A. 50° B. 90°
C. 80° D. 100°

30. A rectangular plot was fenced with three strands of wire. If the plot measured 100 m by 50 m. What was the length of the wire used?

- A. 150m B. 600m
C. 300m D. 900m

31. Njogu gave 0.5 of his land to his daughter and 0.25 to his son. If he had 20 hectares of land, how many hectares was he left with?

- A. 20 B. 5
C. 10 D. 15

32. A husband is 12 years older than his wife. Their daughter is a quarter as old as the mother. If the daughter is x years old. What is the sum of their ages?

- A. $12 + 9x$ B. $12 + 5x$
C. $12 - 9x$ D. $12 - 5x$

33. The area of a right angled triangular plot is 2 ares. If one of the shorter sides is 40m, What is the length of the other shorter side?

- A. 10 m B. 100m
C. 20m D. 50m

34. Ali bought a vest from a shop which allowed a 15% discount on the marked price. If he paid sh 323, what was the marked price of the vest?

- A. sh 323 B. sh 437
C. sh 338 D. sh 380

35. March 1st 2009 was on a Sunday. What day of the week was the 1st February the same year?

- A. Saturday B. Sunday
C. Friday D. Monday

36. In the figure below, find the area of the shaded part ($\pi = \frac{22}{7}$)

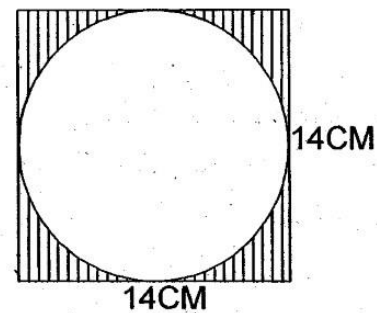

- A. 154 cm^2 B. 44 cm^2
C. 196 cm^2 D. 42 cm^2

37. What is the value of $\frac{5}{8} + \frac{1}{8} \div \frac{2}{3} - \frac{3}{8}$?

- A. $\frac{3}{4}$ B. $\frac{7}{16}$
C. $\frac{1}{3}$ D. $\frac{13}{56}$

38. Three hundred square tiles cover the floor of a room measuring 12m long and 9m wide. What is the length of each tile in centimetres?

- A. 3600 B. 192
C. 120 D. 60

39. A wooden box has a mass of 5kg When empty and 125 kg when packed with 60 books. What is the mass of the wooden box when packed with 40 such books?

- A. 87kg B. 80 kg
C. 85kg D. 180 kg

40. The length of a rectangle is $(3 + 2x)$ cm and its breadth is $(2 + x)$ cm. If the perimeter of the rectangle is 34cm, what is the area of the rectangle?

- A. 66 cm^2 B. 15 cm^2
 C. 70 cm^2 D. 72 cm^2

41. The temperature of ice was -15°C . It was warmed until the temperature became 75°C .

What was the rise in temperature?

- A. 60°C B. 90°C
 C. 100°C D. 190°C

42. What is the square root of 0.9216?

- A. 0.86 B. 0.96
 C. 9.6 D. 0.76

43. Six men can weed a piece of land in 10 days.

How many more men are needed if the work is to be completed in 4 days

- A. 15 B. 11
 C. 9 D. 5

44. A tank is $\frac{3}{5}$ full of water. After 330 litres of water are drawn out, it becomes $\frac{2}{7}$ full. What is the capacity of the tank in litres?

- A. 880 L B. 705L
 C. 1050L D. 550L

45. Which fraction among the following has the smallest value?

- A. $\frac{5}{8}$ B. $\frac{3}{8}$
 C. $\frac{7}{9}$ D. $\frac{9}{11}$

46. The circumference of a circle is 264cm. What is the radius of the circle?

- A. 44cm B. 88cm
 C. 84cm D. 42cm

47. Calculate the area of the quadrilateral drawn below

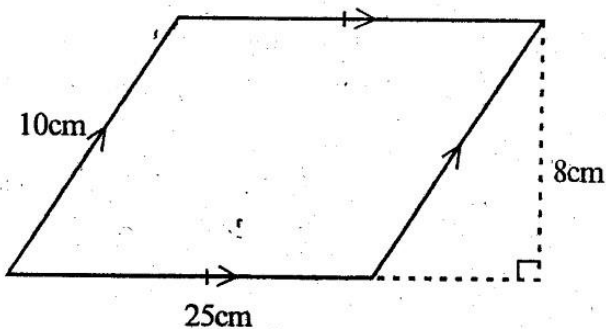

- A. 200 cm^2 B. 140 cm^2
 C. 250 cm^2 D. 100 cm^2

48. The table below shows fares between different towns

A					
40	B				
50	35	C			
60	45	30	D		
70	50	35	25	E	
90	65	40	30	20	F

A student travelled from town F to town

A via C. How much did he pay?

- A. sh 100 B. sh 40
 C. sh 90 D. sh 50

49. Increase 350 in the ratio 7:5

- A. 490 B. 600
 C. 250 D. 554

50. What is the value of x in the equation

$$\frac{y+4}{15} + \frac{2y-5}{5} = \frac{2}{5} ?$$

- A. $3\frac{2}{7}$ B. $3\frac{4}{7}$
 C. $2\frac{3}{7}$ D. 3

STEGA SERIES

STANDARD EIGHT 2015

SCIENCE

Time: 1 hour 40 min

- Which one of the following pests attack the leaves of plants?
A. cutworm B. stalkborer
C. aphids D. weaver bird
- A piece of wood weighing 100g floats on water while an iron pin weighing 1g sinks in the same water. This is due to the indifference in _____
A. mass B. material
C. shape D. weight
- Class five pupils made the weather instrument below.

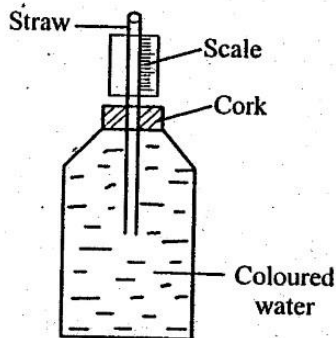

To be able to make accurate measurements, the pupils are supposed to use _____

- a narrow straw
 - bottle without a cork
 - clear water
 - scale numbered from top to bottom.
- The following are characteristics of clouds.
(i) white in colour
(ii) low in the sky
(iii) look like bundles of cotton wool
(iv) dark grey in colour
Which characteristics are for cumulus clouds?
A. i, ii, iii B. ii, iii, iv
C. i, iii, iv D. i, iii, iv
 - Which deficiency disease is caused by lack of adequate mineral salts in the diet?
A. Kwashiorkor B. Marasmus
C. Rickets D. Typhoid
 - Which one of the following is not necessary when investigating the rise of water in soil?
A. Tubes B. Funnel
C. Dry soils D. Water

7.

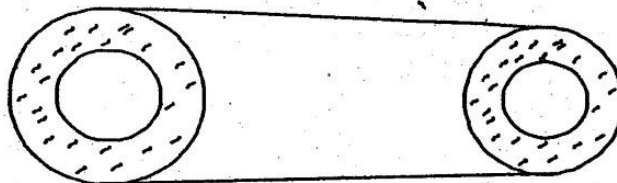

The diagram above shows a blood vessel; Which one of the following is **NOT** true about the blood vessel above?

- blood flows in it in pulses
 - it has valves
 - blood flows under low pressure
 - they carry blood to the heart
- Which is the last step in separating a mixture of sand, iron filings and salt where both salt and iron filings are to be recovered?
A. dissolving B. using a magnet
C. decanting D. evaporation
 - Which one of the substances expands the most when heated?
A. rock B. oxygen
C. water D. ice
 - Which one of the following is **TRUE** about HIV/AIDS? HIV and AIDS may be spread by _____
A. hugging infected persons
B. transfusion of screened blood
C. mother to foetus during pregnancy
D. sharing unsterilized razor blades
 - Which of the following organs in the female reproductive system does ovulation take place?
A. oviduct B. ovary
C. uterus D. vagina
 - Class five pupils dipped a young seedling in a container with coloured water overnight. They then cut the stem. Which function of the stem were they investigating?
A. transport B. absorption
C. support D. food storage

13. The diagram below shows a set up used to demonstrate a certain process.

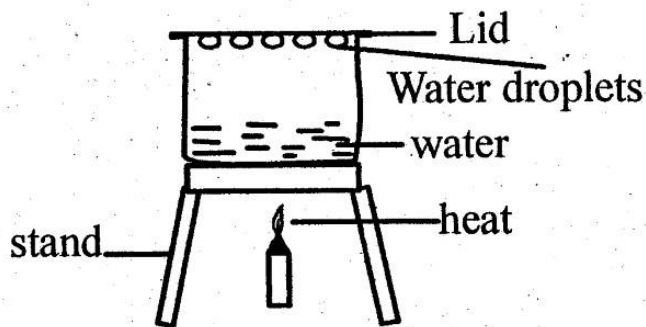

The process investigated is _____

- A. condensation B. evaporation
C. melting D. freezing
14. Which one of the following pairs of diseases are infants immunized against at birth?
A. Polio and Tuberculosis
B. Polio and Diptheria
C. Tetanus and whooping cough
D. Measles and Yellow fever
15. Which one of the following will not help one to have strong and healthy teeth?
A. excersing teeth by eating carrots
B. visiting a dentist regularly
C. using dental floss to remove food between the teeth
D. eating biscuits ocssionally
16. Which of the following is **LIKELY** to release nutrients to the soil immediately?
A. compound fertilizer
B. organic mulches
C. farmyard manure
D. compost manure
17. Which of the following components of blood is involved in clotting of blood after an injury?
A. Red blood cells B. platelets
C. White blood cells D. plasma
18. Which one of the following pairs of animals have scales on their bodies?
A. frog and snake
B. tortoise and toad
C. crocodile and shark
D. platypus and lizard
19. Which of the following is the cheapest method of preserving food?
A. cannig B. salting
C. refrigeration D. drying
20. When constructing a beam balance, the hole should

- be _____
A. too wide
B. at the balancing point
C. at the middle
D. at the end

21. A man was seen using round sticks when pushing a heavy carton along a flat surface. What was the work of the round sticks?
A. to reduce the force that opposes motion
B. to make the load lighter
C. to make the carton last longer
D. to increase friction.
22. The chart below shows classification of plants.

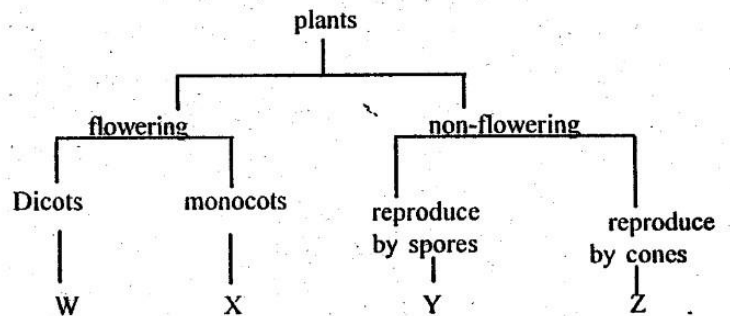

Which plant would fit in part W, X, Y and Z respectively?

- A. beans, millet, cypress, mucor
B. peas, sorghum, cedar, moss
C. moss, cedar, cypress, sorghum
D. peas, maize, fern, cypress
23. Which one of the following diseases is prevented by maintaining proper hygiene?
A. malaria B. Bilharzia
C. chancroid D. Rickets
24. Which one of the following is a function of the amniotic fluid?
A. keeps the foetus moist
B. allow passage of food
C. allows passage of oxygen
D. helps to remove waste
25. Which one of the following statements is **NOT** true about commercial feeds of animals?
A. They depend on the type of animals
B. They are given depending on age of the animal.
C. They are given to animals under zero grazing only
D. Some are given as the only feed.
26. The substance put in the body of a healthy person to protect him from a particular disease are known as _____
A. supplements B. antibodies
C. vaccines D. dosage

27. The diagram below shows changes of state of matter
 .solid \xleftarrow{x} liquid \xrightarrow{y} gases
 Name the process marked X and Y respectively
 A. melting and evaporation
 B. freezing and evaporation
 C. freezing and condensation
 D. melting and condensation
28. Which of the following machines has the position of the fulcrum between the load and the effort when in use?
 A. crowbar B. spade
 C. wheelbarrow D. claw hammer
29. The following are sources of electricity EXCEPT?
 A. solar panels B. car batteries
 C. dry cells D. dam
30. The diagram below shows an experiment carried out by class five pupils.

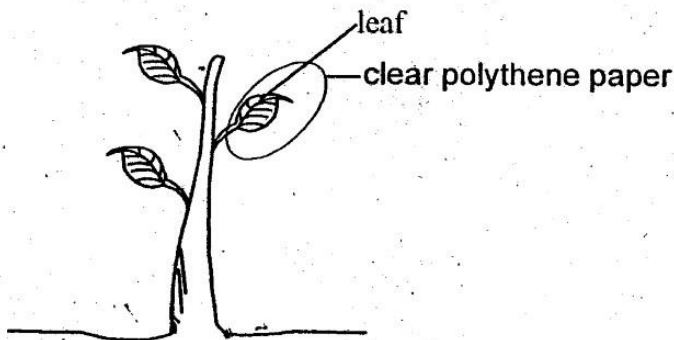

- Which observation did the pupils make after some hours?
 A. transpiration
 B. water droplets inside the paper
 C. leaf turned brown
 D. photosynthesis
31. Which one of the following groups comprises of materials that allow some light to pass through them but one cannot see through them?
 A. oiled paper, tinted glass, dirty water
 B. air, clean water, clear glass
 C. milk, mirror, wood
 D. dirty water, clear glass, air
32. The following are stages during birth process. Which one shows the correct order in which they take place
 A. birth → cervix dilates → tying of cord → removal of after birth
 B. removal of after birth → birth → cervix dilates → cutting of the cord → tying
 C. cervix dilates → birth → tying of cord → cutting of the cord → removal of after birth

- D. cervix dilates → birth → cutting of cord → tying of cord → removal of after birth
33. The following are characteristics of all animals EXCEPT?
 A. they breathe B. they walk
 C. they feed D. they excrete
34. Plants depend on other plants for _____
 A. pollination B. medicine
 C. decomposition D. shade
35. The following are importance of water which one is LEAST?
 A. making blood
 B. cooling the body
 C. preventing constipation
 D. remove waste from the body
36. Kimani, a class six boy had knocked up knees and weak bones. Which one of the following comprises of food that should be included in his diet?
 A. meat, fish, eggs, oranges
 B. fish, liver, green vegetables, milk
 C. fish, meat, beans, peas
 D. ugali, rice, chapati, arrowroots
37. People working in noisy factories protect their eardrums using _____
 A. ear muffs
 B. ear phones
 C. loudspeakers
 D. microphones
38. Which one of the following is CORRECTLY matched with its product?
 A. cow - wool
 B. sheep - milk
 C. broilers - eggs
 D. goat - mohair
39. The diagram below shows an experiment carried out by class five pupils.

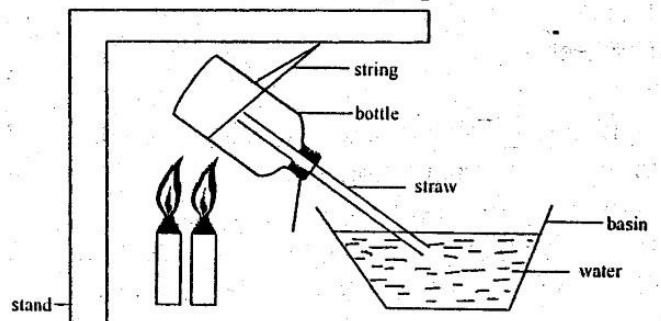

- It is used to demonstrate that _____
 A. air occupies space
 B. air expands on heating
 C. metals expand on heating
 D. water expands on heating

40. Which one of the following is NOT a myth about HIV/AIDS?
 A. AIDS is a curse
 B. AIDS is a disease of immoral people
 C. AIDS has no cure
 D. people with AIDS are thin
41. Class six pupils collected the following materials.
 (i) ruler
 (ii) water
 (iii) basin
 Which aspect of light were they investigating?
 A. bending of light
 B. reflection
 C. dispersion
 D. splitting
42. The following are effects of drugs.
 (i) rape
 (ii) withdrawal
 (iii) lack of concentration
 (iv) truancy
 (v) fight
 Which group comprises of social effects only?
 A. i, iii, iv
 B. i, iv, v
 C. i, ii, v
 D. i, iii, v
43. Which one of the following is NOT a sexually transmitted infection?
 A. Chancroid
 B. Gonorrhoea
 C. Bilharzia
 D. Syphilis
44. Which type of soil erosion can be demonstrated by pouring water using a can that has holes at the bottom
 A. Gully
 B. Rill
 C. Sheet
 D. Splash
45. Which one of the following methods cannot be used to control waterborne diseases?
 A. sleeping in well ventilated rooms
 B. draining stagnant water
 C. wearing protective clothes
 D. washing fruits with clean water
46. The following materials are allowed in and out of the placenta except _____
 A. oxygen
 B. food
 C. mother's blood
 D. carbon dioxide
47. The following are ways of conserving water.
 (i) collecting water in dams
 (ii) using water more than once
 (iii) repairing leaking taps and pipes

- (iv) using drip irrigation
 (v) mulching
 (vi) closing taps when not in use.

Which one of the above comprises only the ways of using water sparingly?

- A. i, ii, iii
 B. iii, iv, vi
 C. ii, iii, iv
 D. iii, iv, v

48. Study the diagram below.

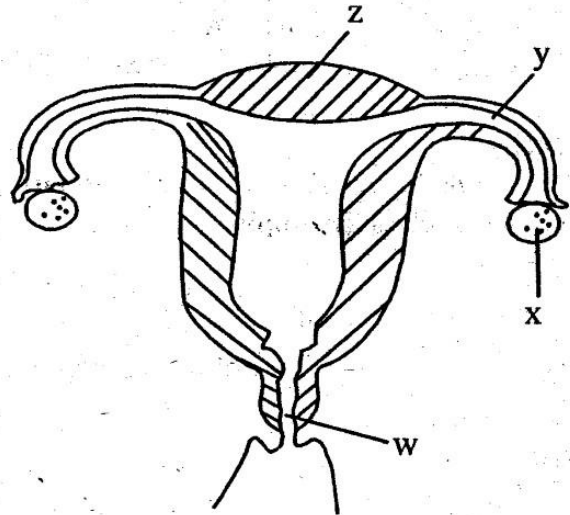

In which part marked X, Y, Z and W does implantation take place?

- A. Y
 B. X
 C. W
 D. Z

49. Which one of the following is an illegal drug?
 A. Bhang
 B. Tobacco
 C. alcohol
 D. Khat
50. When modelling the solar system, which of the following is the fourth step?
 A. model sun and planets using paper match.
 B. draw the orbits
 C. fix the planets on each orbit and the sun using thorns
 D. fix the manilla on the soft board.

STEGA SERIES

STANDARD EIGHT 2015

ENGLISH

Time: 1 hour 40 minutes

Read the passage below and choose the best alternative for blank spaces numbered 1-15

The war had been _____ 1 _____ about for a long time. Our leader had been told to _____ 2 _____ gracefully _____ 3 _____ he was stubborn. He _____ 4 _____ more arrogant _____ 5 _____ adamant. He had believed _____ 6 _____ much _____ 7 _____ himself and his army that he forgot that the enemy was _____ 8 _____ powerful. He did not take _____ 9 _____ account the _____ 10 _____ his citizens _____ 11 _____ have to suffer. _____ 12 _____ when two bulls fight it is the _____ 13 _____ that suffers. I _____ 14 _____ whether he was _____ 15 _____ of this old adage.

- | | | | | |
|-----|--------------|-------------|-----------------|-----------------|
| 1. | A. discussed | B. said | C. talked | D. focussed |
| 2. | A. give in | B. give up | C. give out | D. give off |
| 3. | A. or | B. rather | C. and | D. but |
| 4. | A. was | B. became | C. got | D. grew |
| 5. | A. and | B. though | C. but | D. or |
| 6. | A. too | B. very | C. so | D. quite |
| 7. | A. with | B. at | C. in | D. on |
| 8. | A. much more | B. much | C. more | D. most |
| 9. | A. with | B. into | C. by | D. onto |
| 10. | A. danger | B. wrath | C. results | D. consequences |
| 11. | A. should | B. will | C. would | D. could |
| 12. | A. After all | B. However | C. Nevertheless | D. Certainly |
| 13. | A. bulls | B. grass | C. horns | D. heads |
| 14. | A. wonder | B. wondered | C. wonder | D. wandered |
| 15. | A. knowing | B. learnt | C. heard | D. aware |

For questions 16-18 replace the underlined with a suitable word.

16. The baby is heavy-eyed.
A. awake B. crying
C. drowsy D. very small
17. He made a clean breast of the whole issue.
A. confessed B. explained
C. discussed D. deceived
18. The knives, forks and spoons were well washed.
A. crockery B. cutlery
C. utensils D. crockeries

Choose the opposite of the underlined.

19. The decision was very rational.
A. unrational B. irrational
C. ilrational D. disrational
20. The mark cannot be erased. It is _____.
A. unrabbable B. fixed
C. indelible D. permanent

In questions 21-23 add question tags

21. They had their lunch early.
A. had they? B. did they?
C. hadn't they? D. didn't they?
22. Sheila never comes late.
A. doesn't she? B. did she?
C. does she? D. didn't she?
23. Come here!
A. will you? B. won't you?
C. shall you? D. shan't you?

Complete

24. The hunter carried a full _____ of arrows.
A. box B. quiver
C. bow D. sack
25. The hotel has beautiful _____ of rooms.
A. soot B. suit
C. suite D. suite

Read the following passage carefully and then answer questions 26-40

Magerio was a proud, rich ruler. Before he became married, he said that whoever became his wife had to have her first children as twins. If she did not, she would have to go. Magerio loved his first wife Wamere dearly but she did not start with twins. She got a handsome baby boy called Mbeko. Magerio was very sad. What was he to do? He had spoken, he said and he had to keep his word. He said that rulers are not expected to change their minds even when they make bad decisions.

One morning, he told Wamere to take Mbeko with her and leave. "What have we done to deserve this?" she asked. "You did not give me twins. I swore that a wife who did not give me twins would go. Go now."

She did not go at once. Wamere knew it was not going to be easy to fight this kind of a fight. She had not done anything wrong yet her husband was making her suffer for something she had no power over. She reported the matter to his assistants. The local medicineman Meme got to know about the unkind action from Magerio's friends.

You must call Wamere and Mbeko back at once. If you fail to do so, many misfortunes will befall our ridge and others. There will be swarms of locusts followed by a long famine. Although Magerio was at first shocked by Meme's words, he soon forgot and boasted that only weak men changed their minds. Meme was just a medicineman, one of his simple people. Besides, he, Magerio was not a weather cock to change direction with every puff of the wind.

Two days later, the locusts came and ate everything except the cassava. Mothers and fathers waited as they saw food crops eaten up. Plague began killing people including Magerio's mother and three brothers of his father. Smallpox killed those spared by the plague. Magerio himself became very ill until he called his wife and son back. He recovered and the plagues stopped.

Unfortunately, he still felt it was wrong to change his mind and so sent his family away again. He told his wife not to tell anybody. As nothing can be hidden from the gods, the diseases came back. This time Magerio became blind. His assistants who ruled the country for him did it badly and the people were unhappy. Magerio was growing thin and it was clear he would die.

When he sent for Meme, he told him that this time he would recall his wife and son for good, but in a weeks time he sent them away again saying that rulers never changed their minds. He then got so sick. His body would stink. He was dying. Meme refused to come. He asked the king's servants to go and look for Gege the medicine woman as she was better in healing.

Magerio kept chasing his wife and son till misfortunes came in large numbers. There were aches in every joint, headaches, bolts, general weakness, colds, toothaches and coughs on top of the plague, small pox and the famine. Magerio groaned, trembled and cried madly. He was dying.

At the graveside, Meme and Gege asked Magerio whether he would keep his family as he had the last chance. He said he had repented his sins and asked for forgiveness. He was taken back to work. He lived well and his homestead became a happy home.

26. When did Magerio declare his wish?
 A. when he was a young boy
 B. when in bachelorhood
 C. after he got married
 D. after marrying and failing to get twins
27. Failure to meet the rulers wishes _____
 A. would lead to chasing away the wife
 B. had no impact
 C. would receive a curse from the ruler
 D. meant he would marry
28. Why was Magerio sad after the birth of Mbeko?
 A. Mbeko was very handsome
 B. The wife did not start with twins
 C. He hated the son
 D. The son wasn't pleasant according to the ruler.
29. Why do you think the ruler was foolish?
 A. he made the wrong decision and stuck to it
 B. he had bad leadership qualities
 C. he was not fair to his wife
 D. he hated the son
30. According to Wamere _____
 A. they were being treated unfairly and didn't deserve it
 B. it was her mistake not to get twins
 C. the ruler was right
 D. the fight was quite easy
31. It's true to say that _____
 A. Wamere had power to produce twins
 B. Magerio did well to chase the wife
 C. Wamere had no power on whether to get twins or not
 D. Wamere had wronged her husband
32. Meme warned of _____ to befall Magerio and others.
 A. blessings
 B. curses
 C. misfortunes
 D. witchcraft
33. Complete, Swarm is to locusts as brood is to chicks. This is called _____
 A. collective nouns
 B. analogy
34. The word ridge can be replaced by _____
 A. valley
 B. island
 C. plain
 D. mountain
35. What would befall Magerio if he did not recall his wife and son?
 A. calamities of butterflies
 B. locusts and a long famine
 C. drought and swarms of locusts
 D. swarm of locusts and flies
36. According to the ruler _____
 A. weak men changed their thinking
 B. strong men changed their minds
 C. only men who weren't strong changed their minds
 D. both strong and weak men should change their minds
37. All the following were consequences of Magerio's stubbornness except?
 A. small pox killed people who had escaped the plague
 B. The ruler's mother and three brothers died
 C. Magerio became very unwell
 D. He recovered before calling his wife and son
38. After the wife was sent back a second time, she was _____
 A. meant to keep it in the dark
 B. was supposed to tell the chiefs
 C. supposed to hide it from the gods
 D. to let the cat out of the bag
39. What made Magerio repent and ask for forgiveness?
 A. he realized he had done wrong
 B. Gege the medicine-woman
 C. he was very ill and was dying
 D. he decided to change his mind
40. What is the best title for this passage?
 A. Magerio the proud ruler
 B. The ruler's family
 C. Magerio repents
 D. poor Mbeko and Wamere

Read the following passage carefully and then use it to answer questions 41-50

Recently the minister for Roads and Public works was put to task to explain why death rates were on the increase in relation to the transport network. In part of his reply, he said that bad roads, unroadworthy vehicles and careless drivers have often been the cases of majority accidents in the country. He added that "If we take these factors at the face value, then we shall not be looking at the root problem of road carnage. For instance, when one talks about bad roads, the question that we should immediately spring into one's mind is why bad roads. Did someone pocket a few thousands or million shillings to approve the roads while it did not meet the required standards?"

Kenya has many bad roads. How many times have you approached road bumps that do not have the white strips only to brake suddenly at your peril and that of your passengers and the vehicles following you. We've heard of many cases of drivers jailed for obstruction, the question we should ask ourselves is why such drivers leave their vehicles on the road instead of the roadside.

Take for instance, the Nakuru-Nairobi road, the answers to why drivers leave their vehicles on the road becomes clear. Recently, some legislators criticised the construction of the road saying that it should not have such steep edges because when a car breaks down on the route, it becomes impossible to push it aside.

Potholes on the roads contribute greatly to accidents. Is it possible to get a permanent solution to this problem? Maybe our roads are not made to the required standards. This might be the reason why potholes form on them after a little while.

Our engineers and government consultants should be firm so that companies do not mint millions out of substandard roads which they delight in constant repairing.

When we talk about roads we cannot do so without mentioning pedestrians. It seems that our planners have never taken seriously the safety of the pedestrians and cyclists. What safety is there for our cyclists? They have to squeeze along the edges of the narrow roads competing with tankers, trucks, buses etc.

It's important that we have paths specifically for pedestrians and cyclists. In this way, we can ease the congestion that is observed on roads such as Jogoo Road and make lives of pedestrians, cyclists and motorists much safer. Many of the vehicles plying our roads are in very bad condition. Maybe the best that can be done is to see how much they can be attended to so that they reach near perfect situation. The jua kali industry is encouraged to help us on this sphere as it is cheaper for the motorist.

A change of attitude and more responsibility in public office is one step towards road safety. Otherwise corruption and other irregularities will persist

41. The minister was put to task this means he _____
A. was asked many questions
B. was held responsible and accountable
C. was told to explain
D. was ordered to write a report
42. Which of the following least causes road accidents according to the passage?
A. overspeeding B. unroadworthy vehicles
C. bad roads D. careless driving
43. The question about bad roads raises concerns about _____
A. how roads were made
B. the number of vehicles using roads
C. the type of vehicles plying on the roads
D. whether somebody misused money meant for roads
44. The word peril can be replaced with _____
A. disadvantage B. demerit
C. danger D. risk
45. According to the passage, some bumps _____
A. are very high
B. are without the white strips
C. are poorly made
D. are ill placed on the roads.
46. When a driver brakes suddenly, he endangers all the following except _____
A. passengers B. he himself
C. oncoming vehicles D. road bumps
47. When drivers leave their cars on the road, this is called _____
A. indiscipline B. obstruction
C. overlapping D. overtaking
48. Its likely that potholes are as a result of _____
A. frequent repairs
B. too much rain
C. substandard construction of roads
D. loose tarmac
49. To ease congestion on the roads _____
A. all motocyclists should drive fast
B. cyclist should use the roads well
C. people should use the main road not paths
D. there should be paths for pedestrians and cyclists
50. The best title for the passage is _____
A. Roads in Kenya
B. Road safety
C. Road accidents
D. Curbing road accidents

JINA LAKO	
NAMBARI YAKO	
JINA LA SHULE YAKO	



STEGA SERIES

KISWAHILI SEHEMU YA PILI: INSHA

DARASA LA NANE 2015

MUDA : DAK 40

SOMA MAAGIZO HAYA KWA MAKINI

1. Kwenye nafasi zilizoachwa hapo juu andika Jina lako, Nambari yako kamili ya mtihani na jina la Shule yako.
2. Sasa fungua karatasi hii, soma kichwa cha insha kwa makini na uandike insha yako kwenye nafasi uliyoachiwa.

YOUR NAME	
INDEX NUMBER	
NAME OF YOUR SCHOOL	

STEGA
SERIES
01

STEGA SERIES
ENGLISH SECTION B: COMPOSITION
STANDARD EIGHT 2015

TIME: 40 MIN

READ THESE INSTRUCTIONS CAREFULLY

- 1. In the spaces provided above write Your Name, Full Index Number and the Name of Your School.**
- 2. Now open this paper, read the Composition subject carefully and write your composition on the lines provided.**

<u>ENGLISH</u>		<u>KISWAHILI</u>		<u>MATHS</u>		<u>SCIENCE</u>		<u>SOCIAL STUDIES</u>		
1. C	31. C	1. A	31. C	1. A	31. B	1. C	31. A	1. D	31. C	61. D
2. A	32. C	2. D	32. B	2. D	32. A	2. B	32. C	2. B	32. A	62. A
3. D	33. B	3. C	33. A	3. C	33. B	3. A	33. B	3. C	33. B	63. C
4. B	34. D	4. B	34. B	4. B	34. D	4. D	34. D	4. A	34. C	64. B
5. A	35. B	5. C	35. B	5. C	35. D	5. C	35. C	5. D	35. A	65. B
6. C	36. C	6. B	36. D	6. A	36. D	6. B	36. B	6. A	36. C	66. D
7. C	37. D	7. D	37. D	7. C	37. B	7. A	37. A	7. C	37. A	67. A
8. A	38. A	8. A	38. C	8. D	38. D	8. D	38. D	8. B	38. B	68. C
9. B	39. C	9. D	39. A	9. B	39. C	9. B	39. B	9. B	39. C	69. B
10. D	40. A	10. B	40. B	10. D	40. A	10. D	40. C	10. B	40. D	70. D
11. C	41. B	11. C	41. D	11. B	41. B	11. A	41. A	11. B	41. C	71. B
12. A	42. A	12. B	42. B	12. B	42. B	12. A	42. C	12. C	42. A	72. A
13. B	43. D	13. D	43. A	13. A	43. C	13. A	43. C	13. C	43. A	73. B
14. C	44. C	14. A	44. B	14. C	44. C	14. A	44. D	14. C	44. B	74. D
15. D	45. B	15. D	45. C	15. A	45. B	15. D	45. A	15. B	45. A	75. A
16. C	46. D	16. C	46. C	16. B	46. D	16. A	46. C	16. A	46. B	76. C
17. A	47. B	17. B	47. B	17. C	47. A	17. B	47. B	17. B	47. C	77. D
18. B	48. C	18. C	48. D	18. B	48. C	18. C	48. D	18. A	48. B	78. B
19. C	49. D	19. B	49. A	19. D	49. A	19. D	49. A	19. C	49. C	79. A
20. B	50. B	20. A	50. B	20. A	50. C	20. B	50. C	20. B	50. A	80. B
21. D		21. A		21. A		21. A		21. D	51. D	81. C
22. B		22. D		22. B		22. D		22. A	52. C	82. D
23. A		23. C		23. D		23. B		23. C	53. A	83. D
24. C		24. A		24. B		24. A		24. B	54. C	84. B
25. D		25. D		25. B		25. C		25. C	55. B	85. A
26. B		26. A		26. A		26. C		26. A	56. C	86. C
27. A		27. D		27. B		27. C		27. A	57. A	87. D
28. B		28. D		28. D		28. A		28. B	58. C	88. A
29. A		29. D		29. C		29. D		29. C	59. C	89. D
30. A		30. A		30. D		30. B		30. C	60. C	90. C

A COMPOSITION MARKING SCHEME

MARKING CRITERION

- The composition will be assessed according to the following guidelines.
 - The maximum mark will be 40 and the minimum (mark 01)
 - Does the script show that the candidate can communicate accurately, fluently and imaginatively in English?

Accuracy (8 marks)

- | | |
|--|---|
| a) Correct tenses and agreement of verbs (4 marks) | b) Accurate use of vocabulary (4 marks) |
| (16) c) Following a sequence (4 marks) | d) Correct punctuation (4 marks) |

Fluency (8 marks)

- | | |
|---|--|
| a) Words in the correct order (4 marks) | b) Sentence connection and paragraphs (4 marks) |
| c) Correct spelling (4 marks) | d) Ideas developed in logical sequence (4 marks) |

Imagination (8 marks)

- Unusual but appropriate use of words and phrases (4 marks)
- Variety of structure (4 marks)

NB: Please, teachers are requested to scrutinize this marking scheme before use, it is worth