

# NYERI COUNTY SECOND EXAM

STANDARD EIGHT - 2015



ENGLISH LANGUAGE



Time: 1Hr 40Min

READ THESE INSTRUCTIONS CAREFULLY

1. You have been given this question booklet and a separate answer sheet. The question paper contains 50 questions.
2. Do any necessary rough work in this booklet.
3. When you have chosen your answer, mark it on the ANSWER SHEET, not in this question booklet.

HOW TO USE THE ANSWER SHEET

4. Use an ordinary pencil only.
5. Make sure you have written on the answer sheet.

YOUR INDEX NUMBER

YOUR NAME

NAME OF YOUR SCHOOL

6. By drawing a dark line inside the correct numbered boxes mark your full index number (i.e. School Code Number and the three-figure Candidate's Number) in the grid near the top of the answer sheet.
7. Do not make any marks outside the brackets [ ].
8. Keep the sheet as clean as possible and **DO NOT FOLD IT**.
9. For each of the questions 1-50 four answers are given. The answers are letter A, B, C, D. In each case only **ONE** of the four answers is correct. Choose the correct answer.
10. On the answer sheet the correct answer is to be shown by drawing a dark line inside the box in which the letter you have chosen is written.

**Example:-**

**In the question paper.**

16. Choose the correctly spelt word

- A. woollen
- B. recieve
- C. acqintance
- D. lighteng

The correct answer is A. (woollen).

**On the answer sheet**

**8.** [A] [B] [C] [D]

**16.** [~~A~~] [B] [C] [D]

**18.** [A] [B] [C] [D]

**24.** [A] [B] [C] [D]

In the first set, the box with the letter D printed in it is marked.

11. Your dark line **MUST** be within the bracket.
12. For each question **ONLY ONE** bracket is to be marked in each of four brackets

This Question Paper consist of 7 printed pages.

**Read the passage below. It contains blank space numbered 1 to 15. Read it and select the best alternative for each blank space from the choices given.**

The level of noise 1 increased the 2 we got to the bus station. 3 Musa said pointing at a new colourful matatu. On its roof was a 4 with words 'NAIROBI EXPRESS' boldly written on it. We quickened our pace 5 it. At the booth office was a 6 waiting for their 7. I gave the attendant a 8 note. He checked the note 9 light. Satisfied it was 10 he pointed at us with his biro pen and asked, 11. I nodded a 12. He wrote 13 book, tore out two tickets and handed them 14 to us. At the entrance we found 15 man who I thought was a tout.

- |                                 |                                  |                               |                    |
|---------------------------------|----------------------------------|-------------------------------|--------------------|
| 1. A. immediately               | B. gradually                     | C. also                       | D. finally         |
| 2. A. closer                    | B. close                         | C. closest                    | D. farther         |
| 3. A. "There?"                  | B. "There!"                      | C. "There!"                   | D. There?          |
| 4. A. poster                    | B. billboard                     | C. signboard                  | D. noticeboard     |
| 5. A. besides                   | B. beside                        | C. toward                     | D. towards         |
| 6. A. short queue of travelers  | B. short queue of travellers     |                               |                    |
|                                 | C. shorter queue of travellers   | D. shorter queue of travelers |                    |
| 7. A. luck to get their tickets | B. turn to acquire their tickets |                               |                    |
|                                 | C. time to draw their tickets    | D. time to sell their ticket  |                    |
| 8. A. five hundred shillings    | B. five hundred shilling         |                               |                    |
|                                 | C. five hundreds shilling        | D. five hundreds shillings    |                    |
| 9. A. against                   | B. under                         | C. in                         | D. at              |
| 10. A. genuine                  | B. fake                          | C. original                   | D. duplicate       |
| 11. A. "For you the two?"       | B. "For the two of you?"         |                               |                    |
|                                 | C. "For all of you two?"         | D. For you the two?"          |                    |
| 12. A. amazement                | B. disagreement                  | C. confirmation               | D. satisfaction    |
| 13. A. rapidly on a receipt     | B. quickly on a receipt          |                               |                    |
|                                 | C. faster on a receipt           | D. more rapidly on a receipt  |                    |
| 14. A from                      | B. in                            | C. up                         | D. over            |
| 15. A. a teenage aged           | B. a teen aged                   | C. a ten aged                 | D. a ten year aged |

**For questions 16 and 17, choose the word that best completes the sentence**

16. Mercy is the \_\_\_\_\_ of the twins.  
A. swiftest  
B. swift  
C. swifter  
D. more swifter
17. The bus \_\_\_\_\_ this route before.  
A. have never plied  
B. has never plied  
C. had never ply  
D. has never ply

**For questions 18 to 20, select the alternative that can best complete the sentences given**

18. Many KDF soldiers sustained \_\_\_\_\_ during the war.  
A. bruises  
**B. wounds**  
C. injuries  
D. damages
19. Kazungu used to collect beautiful stamps, \_\_\_\_\_?  
A. didn't he  
B. does he  
C. dont he  
D. did he
20. Let us do Mathematics today, \_\_\_\_\_?  
A. shan't we  
B. do we  
C. don't we  
D. shall we

**For questions 21 to 23, choose the alternative which means the same as the underlined words**

21. The police chased the burglar but he got way  
A. appeared                      B. escaped  
C. surrendered                    D. despaired

22. The classteacher said that she could not put up with that kind of noise.  
A. agree with  
B. accomodate  
C. tolerate  
D. appeal
23. My uncle used to be a heavy smoker but he gave up the habit two years back.  
A. continued                      B. decided  
C. extinguished                    D. stopped

**For questions 24 and 25, choose the correct arrangement of the sentences given to make a sensible paragraph.**

24. (i) After the coffee has been processed, it is transported to Nairobi.  
(ii) They pick the coffee once or twice a week and take it to the pulping mills the same day it is picked  
(iii) The small- scale farmers sell the coffee through co - operative societies  
(iv) The pulping mills are owned and managed by co -operative societies.  
A. iv, i, ii  
B. i, iii, ii, iv  
C. iii, iv, i, ii  
D. iii, ii, iv, i
25. (i) Tourists flock to the park from all over the world  
(ii) Among the attractions are lion, zebra and antelope.  
(iii) Serengeti is one of the biggest game reserves in Eastern Africa  
(iv) However; it is only a very lucky tourist who would spot cheetah  
A. iii, i, ii, iv  
B. iii, ii, i, iv  
C. iii, iv, i, ii  
D. iii, i, iv, ii

**Read the passage below and answer questions 26 -38.**

There it was again. In the deep morning hush was a sound of pain, and repeated over and over. It was a kind of shortened scream as if someone, something had no breath to scream. He came to himself, looked about him and called for the dogs. They did not appear, they had gone off on their own business, and he was alone. Now he was clean sober, all the madness gone. His heart beating fast, business of that frightened screaming, he stepped carefully off the rock and went towards a belt of trees. He was moving cautiously, for not so long ago. he had seen a leopard in just the same spot.

At the edge of the trees he stopped and peered, holding his weapon ready. He advanced, looking steadily about him, his eyes narrowed. Then all at once, in the middle of a step, he faltered and his face was puzzled. He shook his head impatiently, as if he doubted his own sight.

There between two trees, against a background of desolate black rock, was a figure from a dream, a strange beast that was horned and drunken - legged but like something he had never imagined. It seemed to be ragged. It looked like a small buck and had black ragged tufts of fur standing up irregularly all over it, with patches of raw flesh beneath..... but the patches of rawness were disappearing under moving back and came again elsewhere and at the time the creature screamed in small gasping screams and leapt drunkenly from side to side as if it were blind.

Then the boy understood. It was a buck. He ran closer and again stood still stopped by a new fear. Around him the grass was whispering and alive. He looked wildly about and then down. The ground was black with ants, great energetic ants that took no notice of him, but hurried and scurried towards the fighting shape, like glistening black water flowing through the grass.

As he drew in his breath-and pity and terror seized him, the breath fell and the screaming stopped. Now he could hear nothing but one bird singing, and the sound of the rustling, whispering ants. He peered over at the writhing blackness that jerked convulsively with the jerking nerves. It grew quieter. There were small twitches from the mass that still looked vaguely like the shape of a small animal.

It came to his mind that he should shoot it and end its pain and he raised the weapon. Then he lowered it again. The buck could no longer feel; its fighting was a mechanical protest of the nerves. It was not that they made him put down the weapon. It was a feeling of range and misery and protest that expressed itself in the thought, If I had not come, it would have died like this, so why should I interfere? All over the bush, things like this happen. They happen all the time. This is how life goes on by living things dying in anguish. He gripped the weapon between his knees and felt in his own limbs the myriad, swarming pain of the twitching animal that could no longer feel and set his teeth, and said over and over again under his breath. I can't stop it. I can't stop it. There is nothing I can do.

He was glad that the buck was unconscious and had gone past suffering so that he did not have to make a decision to kill it even when he was feeling with his whole body. This is what happens, this is how things work.

26. According to the story, the creature that screamed was \_\_\_\_\_
- a leopard
  - a lion
  - a dog
  - a buck
27. Why was the buck "like a figure from a dream" to the boy?
- He saw it in his dream
  - He was clean sober
  - It was stranger than his wildest imagination.
  - It screamed and slept drunkenly from side to side
28. What were the black ragged tufts of fur standing up irregularly all over the animal?
- Flesh
  - Wounds
  - Ants
  - Soil
29. Why was the creature leaping drunken from side to side?
- It had been shot
  - It was nervous
  - It was blind
  - It had been attacked by ants
30. Why did the hunter stop running towards the buck?
- He noticed something puzzling
  - He looked like a small animal
  - He had seen a leopard
  - He feared the sound of the ants
31. What made the hunter change his mind about shooting the buck?
- It was writhing convulsively.
  - He felt pity for the animal.
  - The creature was as good as dead
  - He feared the creature
32. The boy's heart was beating fast because
- he had heard the frightening scream
  - he was very excited
  - he felt there was danger
  - he had a narrow escape from death
33. The boy moved cautiously towards the belt of trees because
- he saw a strange beast in the plains
  - he had spotted a leopard there earlier
  - he felt some instincts warning him
  - he was not certain about the direction of the scream
34. "..... but the patches of rawness were disappearing under moving back and came again elsewhere. This means that
- the ants bit the skin of the buck and then moved over it
  - the dark areas of black turned into a raw flesh again and again
  - the ants covered the raw flesh, and more areas became raw as they moved over it
  - the-ants attacked the buck until it was a mass of black
35. According to the passage, it is true to say that the ants
- bit the boy as he stepped on them
  - stopped advancing as soon as the buck had fallen
  - streamed towards the buck in a column
  - took no notice of the boy but hurried towards the buck

36. The writer reveals that the boy felt
- A. frightened by the sight of the ants attacking the buck
  - B. horrified that the buck had suffered before it died
  - C. anger at his inability to avert anguished death of wild animals
  - D. rage and misery that he could not kill all the ants

For questions 37 and 38, choose a word or phrase that is closest in meaning to the underlined words from the passage.

37. He faltered and his face was puzzled.
- A. Stumbled
  - B. Hesitated
  - C. Stopped
  - D. Stiffened
38. Jerked convulsively with the jerking nerves
- A. moved suddenly
  - B. ran swiftly
  - C. jumped up
  - D. twisted violently

Read the following passage then answer questions 39 - 50.

Lucy is 14 years old and has changed a lot over the past few months. She is less communicative than before. This confuses her mother as can be seen from own words.

"I have always got along well with my daughter, but now there is a great distance growing between us.

Before, she told me everything she did at school and what she talked about with her friends. Now, days go by without a word said between us. And with her father, well, she only listens. Sometimes she answers his questions in a single word. Her disinterest in conversations with her is disheartening.

However, she seems mature in everything else. I have to admit that she is often right when arguing with her father. I also see that when she is doing something she likes, she is tireless.

The other night she stayed up very late doing some homework in Science, which is a subject which interests her deeply. The next morning, in spite of having slept very little, she was as happy as a lark and very affectionate. I asked her to telephone her aunt because she had an operation. I thought she was going to refuse. But she smiled answering, "Of course mom. That's what families are for, aren't they?" I realise that Lucy has changed and not necessarily in a bad way; but often I don't know how to deal with her."

Girls and boys become different when they reach adolescence. These changes confuse them. Even their parents, as well as other adults find them difficult in spite of the fact that older people know these changes are natural. The adolescence is changing from being a child to an adult. And the responsibilities and privileges are different from one stage to another.

Puberty is the phase immediately before adolescence or it may be considered to be its first step. Its main characteristics are the physiological changes pertaining to this age. The origin of the word, which comes from the Latin word "pubes" confirms the pubis as the place which shows the onset of puberty; the pubic hair announces the changes which accompany this stage.

Depending on individuals and their surroundings, the length of adolescence may vary from a few months to several years.

Adolescence is also accompanied by significant intellectual growth. Adolescents become more and more capable of thinking for themselves, reasoning, identifying inconsistencies and arguing.

In many ways, society prolongs the adolescent phase because of its emphasis on the adolescents getting a job. This causes many parents to become impatient, because they want the adolescent storm to pass quickly, and for the young person to 'settle down'.

Adolescents have a physical and psychological energy which may produce incredible results. They also have a high level of creativity which in most cases tends to disappear or at least moderate itself mostly when adulthood is reached. They are capable of loving intensely or of rejecting something or someone with equal strength.

In short, adolescents are full of resources which may be used to their advantage. If they find understanding among adults, they feel supported to channel their talents into positive, healthy lifestyle.

- |  |   |
|--|---|
| <p>39. According to the first paragraph, it is untrue to say that</p> <ul style="list-style-type: none"><li>A. her mother was unsure about the situation</li><li>B. Lucy has always been quiet girl .</li><li>C. Lucy's mother was not ready for the changes</li><li>D. changes in Lucy started a few months before she was fourteen</li></ul>   | <p>41. The word <u>disheartening</u> means all the following except</p> <ul style="list-style-type: none"><li>A. reassuring</li><li>B. discouraging</li><li>C. frustrating</li><li>D. demoralizing</li></ul>  |
| <p>40. The phrase <u>there is a great distance growing between us</u> as used in the passage implies that</p> <ul style="list-style-type: none"><li>A. Lucy does not like accompanying her mother to distant places</li><li>B. mother and daughter are now living apart</li><li>C. mother and daughter are no longer free to each other as before</li><li>D. Lucy is slowly turning to criminal activities</li></ul> | <p>42. Why do you think Lucy answers her father's questions in a single word?</p> <ul style="list-style-type: none"><li>A. Because of dislike of conversations</li><li>B. Because of her desire not to prolong conversations</li><li>C. Because of dislike of her father</li><li>D. Because of disrespect to the parents</li></ul> <p>43. "That's what families are for" What did Lucy mean in this statement?</p> <ul style="list-style-type: none"><li>A. That families should expect problems</li><li>B. That Lucy loved her aunt than her parents</li><li>C. That family members should care for each other.</li><li>D. That Lucy was a pretender</li></ul> |

44. According to the passage it is true to say that
- A. onset of puberty happens at the same time in all.
  - B. pubic hair announces the end of puberty
  - C. puberty phase comes-after adolescence
  - D. puberty stage does not happen to some people
45. Parents want the adolescents "storm" to pass quickly. This implies that parents
- A. are uncomfortable with this stage of growth in their children
  - B. wish they did not have such children
  - C. would wish the stage to take a very short time
  - D. wish they were adolescents themselves
46. The word incredible as used in the passage can be replaced with three of the following except
- A. obvious
  - B. unimaginable
  - C. fantastic
  - D. unthinkable
47. According to the last but one paragraph, it is false to say that
- A. adolescents can hate something strongly
  - B. adolescents can love someone strongly
  - C. adults are more imaginative than adolescents
  - D. as they grow older, creativity in adolescents diminishes
48. In the last paragraph, we learn that
- A. adolescents will be more useful if adults understand and support them
  - B. adolescents take advantage of other people
  - C. adolescents need to understand their parents
  - D. adolescents are not capable of using their resources
49. The best advice to a parent of an adolescent is to ask him or her to be \_\_\_\_\_
- A. tough
  - B. patient
  - C. unconcerned
  - D. strict
50. Which would be the most appropriate title for this-passage?
- A. The problems of adolescence
  - B. Avoiding adolescence
  - C. Adolescence or puberty?
  - D. Understanding adolescence



# NYERI COUNTY SECOND EXAM



## STANDARD EIGHT - 2015



### SCIENCE

Time: 1Hr 40Mins

#### READ THESE INSTRUCTIONS CAREFULLY

1. You have been given this question booklet and a separate answer sheet. The question paper contains 50 questions.
2. Do any necessary rough work in this booklet.
3. When you have chosen your answer, mark it on the ANSWER SHEET, not in this question booklet.

#### HOW TO USE THE ANSWER SHEET

4. Use an ordinary pencil only.
5. Make sure you have written on the answer sheet.

YOUR INDEX NUMBER

YOUR NAME

NAME OF YOUR SCHOOL

6. By drawing a dark line inside the correct numbered boxes mark your full index number (i.e. School Code Number and the three-figure Candidate's Number) in the grid near the top of the answer sheet.
7. Do not make any marks outside the brackets [ ].
8. Keep the sheet as clean as possible and **DO NOT FOLD IT**.
9. For each of the questions 1-50 four answers are given. The answers are lettered A, B, C, D. In each case only **ONE** of the four answers is correct. Choose the correct answer.
10. On the answer sheet the correct answer is to be shown by drawing a dark line inside the box in which the letter you have chosen is written.

**Example:-**

**In the question paper.**

4. Which one of the following is **NOT** a controlled method of grazing?

- A. Zero grazing
- B. Strip grazing
- C. Herding
- D. Tethering

The correct answer is **C. (herding)**.

**On the answer sheet**

**4.** [A] [B] [] [D]

**14.** [A] [B] [C] [D]

**24.** [A] [B] [C] [D]

**34.** [A] [B] [C] [D]

In the first set, the box with the letter **D** printed in it is marked.

11. Your dark line **MUST** be within the bracket.

12. For each question **ONLY ONE** bracket is to be marked in each of four brackets.

**This Question Paper consist of 8 printed pages.**

- Which one of the following is not a disadvantage at hard water?
  - More energy is used when washing clothes
  - Forms scale and fur on cold water pipes
  - Wastes a lot of soap
  - Forms scum with soap
- Which one of the following ways of controlling air pollution is the least effective?
  - Do not burn tyres and plastic materials
  - Drive vehicles with well maintained engines
  - Avoid burning vegetation cover
  - Avoid use of harmful aerosol sprays

The diagram below represents a simple electric circuit

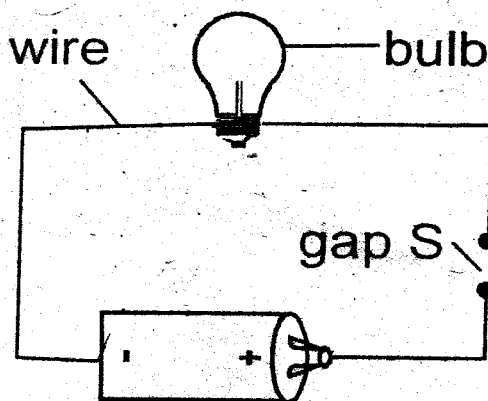

- A strand of thin steel wool wire was put across gaps. The bulb did not light because
  - the circuit wires were wrongly connected
  - the steel wool wire was very thin

- there was a gap
  - there was only one dry cell
- Which one of the following components of air has the least amount?
    - Carbon dioxide
    - Rare gases
    - Nitrogen
    - Oxygen
  - Which one of the following weather measuring instruments measures a different aspect of weather from the others?
    - Windvane
    - Air thermometer
    - Windsock
    - Raingauge
  - Which one of the following statements describes hard water?
    - Water that has not been boiled
    - Water that lathers easily with soap
    - Water that is suitable for drinking
    - Water that saves soap during washing
  - Which of the following is not a method of conserving soil?
    - Avoid excessive use of farm chemicals
    - Avoid dumping kitchen waste on soil
    - Avoid burning vegetation cover
    - Avoid overstocking

8. Which one of the following diagrams represents what happens after a ray of light strikes a flat, smooth, plane surface?

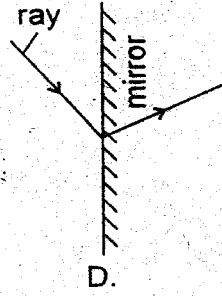
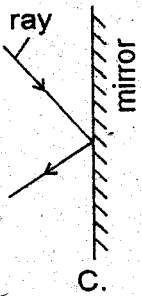
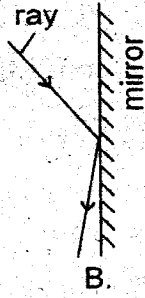
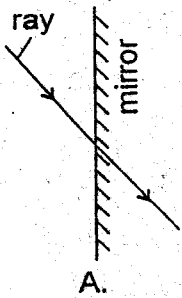

9. The chart below represents a simple classified chart of substances.

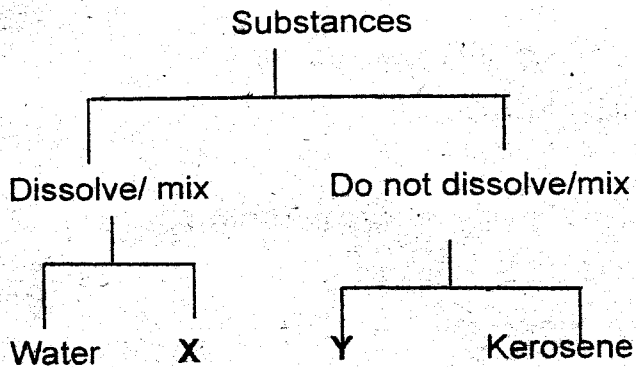

Which substances are represented by X and Y?

- |   |  |
|---|--|
| <p><b>X</b></p> <ul style="list-style-type: none"> <li>A. Cooking oil</li> <li>B. Sand</li> <li>C. Sugar</li> <li>D. Glucose</li> </ul> | <p><b>Y</b></p> <ul style="list-style-type: none"> <li>Petrol</li> <li>Saw dust</li> <li>Methylated spirit</li> <li>Cooking oil</li> </ul> |
|---|--|

10. Which of the following is the seventh and third planets respectively?

- A. Uranus and earth
- B. Mars and Uranus
- C. Earth and Uranus
- D. Saturn and Earth

11. Which of the following methods helps to conserve water the least?

- A. Drip irrigation
- B. Re - using
- C. Mulching
- D. Harvesting

12. Which-one of the following major components of the environment is the largest?

- A. Air
- B. Soil
- C. Plants
- D. Water

13. The diagrams below represent set-ups that were used to demonstrate a certain aspect of heat.

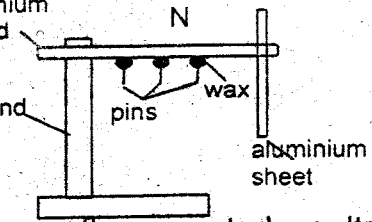
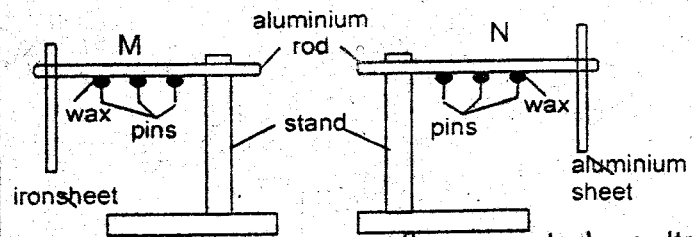
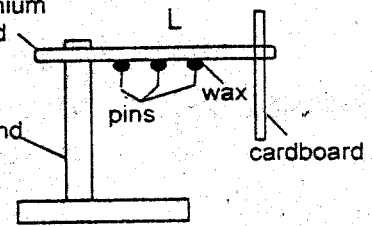
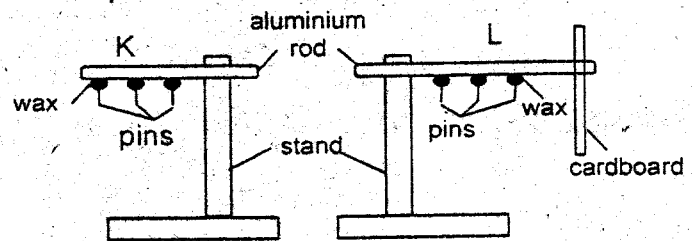

In which set - up were the expected results observed?

- A. K

- B. L
- C. M
- D. N

14. Which one of the following substances expand most when heated?
- A. Aluminium rod
  - B. Water
  - C. Carbon dioxide
  - D. Petrol
15. Which one of the following is not a water - borne disease?
- A. Cholera
  - B. Malaria
  - C. Typhoid
  - D. Bilharzia
16. Which one of the following items of water storage helps to keep drinking water cool and clean?
- A. Pot
  - B. Tank
  - C. Drum
  - D. Bucket
17. The following are excretory organs except
- A. kidney
  - B. liver
  - C. skin
  - D. lungs

18. Blood vessel through which oxygenated blood flows to the heart is \_\_\_\_\_
- A. aorta
  - B. pulmonary artery
  - C. vena cava
  - D. pulmonary vein
19. Which of the vaccines is administered to infants at birth, 6 weeks and at 14 weeks?
- A. Polio
  - B. BCG
  - C. Anti -Measles
  - D. D.P.T
20. HIV / AIDS can be spread through the following ways except
- A. sexual intercourse
  - B. seminal fluids
  - C. through mosquito bites
  - D. blood transfusion
21. The ability of the body to fight against diseases is called \_\_\_\_\_
- A. syndrome
  - B. deficiency
  - C. immunity
  - D. acquire
22. A boy took an expired medicine. Which among the following should not be done to him?
- A. Put him in a recovery position
  - B. Clear his mouth using any material
  - C. Take the victim to hospital
  - D. Try to make him vomit

23. The following are signs of unhealthy crops except

- A. reduced harvest
- B. stunted growth
- C. curled leaves
- D. spots and streaks on leaves

Use the diagram to answer the question below.

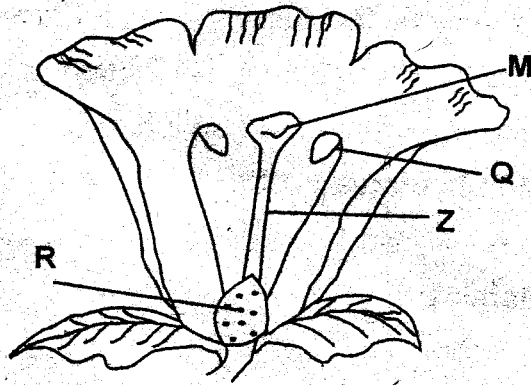

24. In the above diagram, where does fertilization take place?

- A. M
- B. R
- C. Q
- D. Z

25. Which plant is wrongly classified in the classification below?

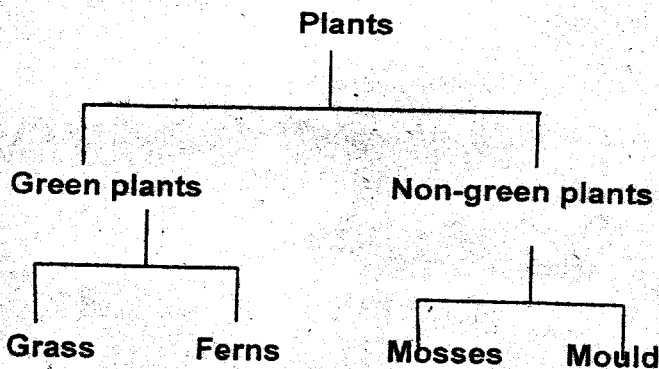

- A. Mosses
- B. Grass
- C. Mould
- D. Fern

26. The following characteristics refer to a particular weed.

- Stem grow along the ground
- Grows near water or under the shade
- Produces blue flowers.
- It has a flexible stem.

Which among the following can fit the description above?

- A. Pig weed
- B. Mexican marigold
- C. Wandering Jew
- D. Oxalis

27. Which one of the following signs and symptoms refer to syphilis?

- (i) Painful sore called chancre on genitals
- (ii) Painful regular sores with red border (bubo)
- (iii) Hard lumps on the skin
- (iv) Pain when passing out urine

- A. i, iv
- B. i, iii
- C. iii, iv
- D. ii, iii

28. Below is a description of a certain drug

- (i) It is a scrub plant
- (ii) Its leaves appear sleepless
- (iii) Its leaves are chewed

Which drug is described above?

- A. Bhang

- B. Cocaine
- C. Khat
- D. Mandrax

29. The following are parts of the female reproductive system except

- A. urethra
- B. uterus
- C. fallopian tube
- D. oviduct

30. What happens during inhaling?

- A. Ribs move out-wards and upwards
- B. Diaphragm becomes c-shaped
- C. Lungs contract and expand
- D. Ribs contracts

31. The description below refers to a human tooth.

- (i) *Has one root*
- (ii) *Chisel shaped*
- (iii) *Used for biting and cutting*
- (iv) *They are four in the upper jaw*

Which teeth is described above?

- A. Premolars
- B. Molars
- C. Canine
- D. Incisors

32. The following are some characteristics of certain animals.

- (i) *Body covered with scales*
- (ii) *Lay eggs.*
- (iii) *Body temperature varies with the surroundings*
- (iv) *Breath through lungs.*

Which one of the following pairs of animals has all the characteristics listed?

- A. Turtle and shark
- B. Lizard and tortoise
- C. Tilapia and frog
- D. Crocodile and platypus

33. Which one of the following is the main constituent of a balanced diet obtained by animals when they feed on lucerne?

- A. Carbohydrates
- B. Proteins
- C. Vitamins
- D. Minerals

34. Which one of the following pairs consists of only animals that have webbed feet?

- A. Turkey and crocodile
- B. Kingfisher and flamingo
- C. Hippopotamus and toad
- D. Frog and duck

35. Which one of the following livestock parasites cannot be controlled by spraying animals?

- A. Mites
- B. Tsetse flies
- C. Fleas
- D. Ticks

36. Which one of the following is true about the use of salt in food preservation? It \_\_\_
- keeps out air and bacteria from reaching food
  - preserves food by absorbing water
  - preserves food by cooling
  - keeps away pests like ants and weevils from food
37. The main reason why a baby needs to be breastfed by the mother is that the milk produced
- helps to build the baby's immunity
  - helps the baby to grow fast
  - helps the baby's bones to be strong
  - is easily digested
38. Maize grains were stored in a granary whose roof was leaking during the rainy season. Which one of the following is likely to be the result of eating the maize?
- Food poisoning
  - Kwashiorkor
  - Fainting
  - High blood pressure
39. Kihenia has been eating food that lacks an important component of a balanced diet. As a result, his bones have become weak and he has become bow - legged. Which of the following foods can help to treat his condition?
- Milk products
  - Sea food
  - Fruits
  - Carrots
40. Which one of the following groups consists of only foodstuffs that are used for-body building and repair?
- Rice, oranges, meat
  - Wheat, fish, maize
  - Beans, potatoes, groundnuts
  - Eggs, peas, milk
41. Which one of the following activities can be used to demonstrate rill erosion?
- Pour water at different positions of a slanting soil
  - Pour water in channels of soil on a slanting surface
  - Pour water on a flat surface of soil
  - Pour water on a flat surface using a tin with many holes
42. Which characteristic is common to all birds and mammals?
- Laying eggs
  - Giving birth
  - Constant body temperature
  - Body covered with fur
43. Class seven pupils set up an experiment as shown below and left the set -up for four minutes.

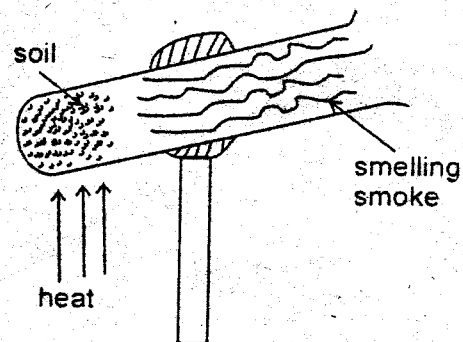

Which one of the following soil components were they investigating?

- A. Air
- B. Water
- C. Humus
- D. Living organisms

44. The below diagram shows preparation of compost manure. What is the reason for adding layer X in the compost heap?

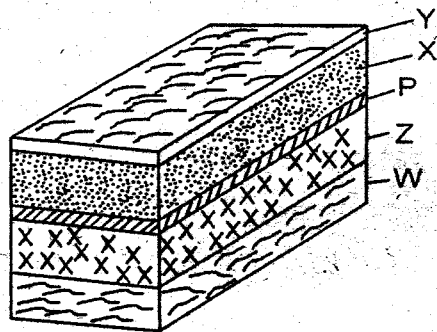

- A. To introduce bacteria to the compost
  - B. To add nutrients
  - C. To feed bacteria
  - D. To prevent evaporation of water
45. Which one of the following ways of improving soil fertility will take the longest time for plants to get nutrients? When using
- A. compost manure
  - B. compound fertilizer
  - C. farmyard manure
  - D. green manure

46. A certain machine when in use can work with load, effort and fulcrum at different positions as shown below in diagrams I and II.

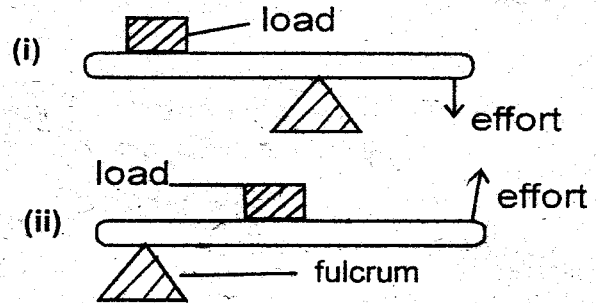

The machine is a \_\_\_\_\_

- A. wheelbarrow
  - B. crowbar
  - C. spade
  - D. claw hammer
47. Newton is a unit for measuring \_\_\_\_\_
- A. mass
  - B. force
  - C. pressure
  - D. volume
48. A beam balance is used to measure \_\_\_\_\_
- A. mass
  - B. density
  - C. volume
  - D. area
49. Friction can be reduced by the following **except**
- A. smoothing
  - B. lubricating
  - C. using rollers
  - D. creating teeth on wheels
50. Which one of the following simple machines is an inclined plane?
- A. Screw jack
  - B. Wheelbarrow
  - C. Hammer
  - D. Pulley



# NYERI COUNTY SECOND EXAM

002

STANDARD EIGHT - 2015

8

Time: 2Hrs 15 Min

## SOCIAL STUDIES & RELIGIOUS EDUCATION

### READ THESE INSTRUCTIONS CAREFULLY

1. You have been given this question booklet and a separate answer sheet. The question paper contains 90 questions.
2. Do any necessary rough work in this booklet.
3. When you have chosen your answer, mark it on the ANSWER SHEET, not in this question booklet.

### HOW TO USE THE ANSWER SHEET

4. Use an ordinary pencil only.
5. Make sure you have written on the answer sheet.

YOUR INDEX NUMBER

YOUR NAME

NAME OF YOUR SCHOOL

6. By drawing a dark line inside the correct numbered boxes mark your full index number (i.e. School Code Number and the three-figure Candidate's Number) in the grid near the top of the answer sheet.
7. Do not make any marks outside the brackets [ ].
8. Keep the sheet as clean as possible and **DO NOT FOLD IT**.
9. For each of the questions 1-50 four answers are given. The answers are lettered A,B,C,D. In each case only **ONE** of the four answers is correct. Choose the correct answer.
10. On the answer sheet the correct answer is to be shown by drawing a dark line inside the box in which the letter you have chosen is written.

#### Example:-

In the question paper.

31. Three of the following are ways of resolving disputes in Kenya today **EXCEPT** through \_\_\_\_\_

- A. mediating
- B. negotiation
- C. reconciliation
- D. revenging

The correct answer is **D. (revenging)**.

On the answer sheet

**16** [A] [B] [C] [D]    **21** [A] [B] [C] [D]    **31** [A] [B] [C] ~~[D]~~    **41** [A] [B] [C] [D]

In the first set, the box with the letter **D** printed in it is marked.

11. Your dark line **MUST** be within the bracket.
12. For each question **ONLY ONE** bracket is to be marked in each of four brackets.

This Question Paper consist of 8 printed pages.

*SOCIAL STUDIES & RELIGIOUS EDUCATION*

## RUNGIRI AREA

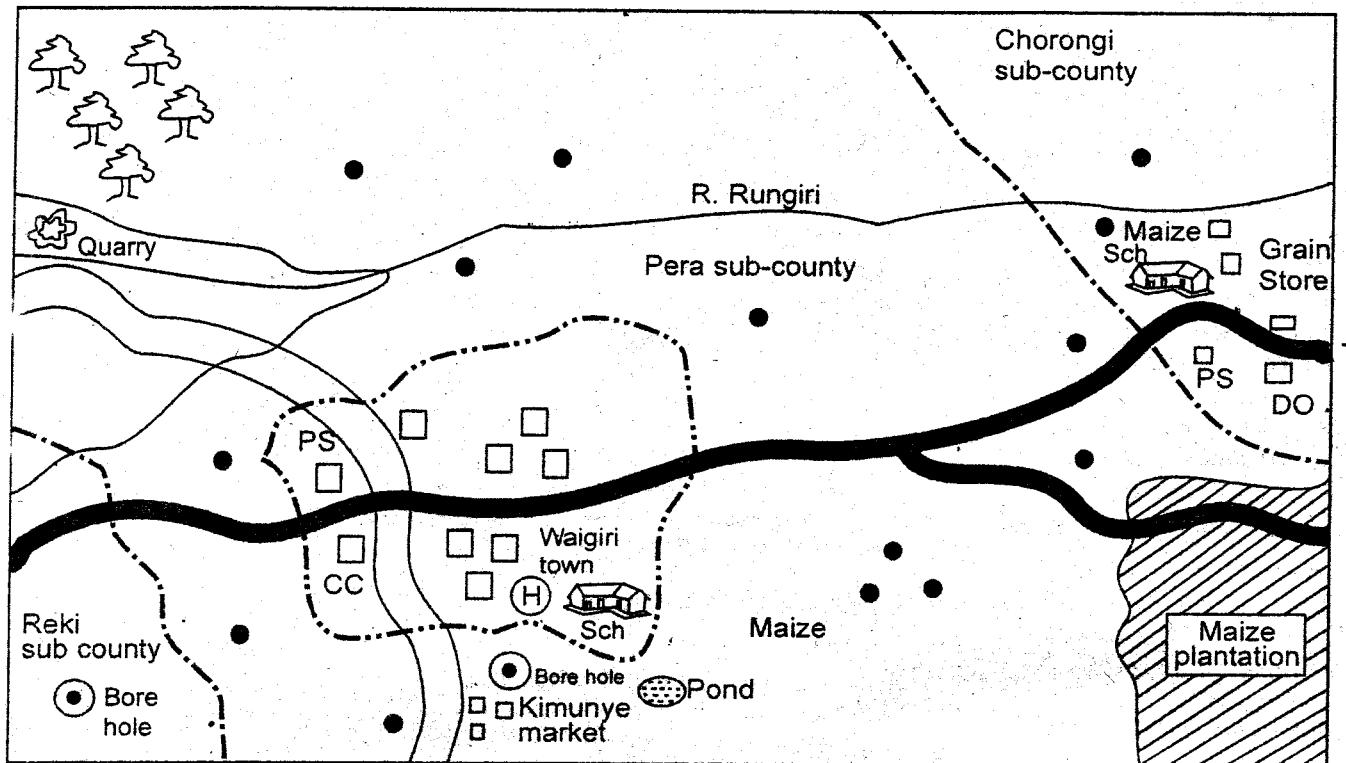

Scale

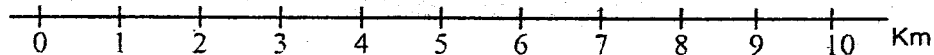

### KEYS

● Settlement	⋯ Town boundary	Sch School	PS Police station
□ Permanent buildings	— Tarmac road	(H) Hospital	CC County commissioner office
- - - Sub-county boundary	~ River	DO District office	
		PO Post office	

### Study the map of Rungiri area and answer questions 1- 7

- The land in Rungiri are slopes from \_  
 A. West to North East  
 B. South East to North West  
 C. North East to South West  
 D. South West to North West
- What is the length of the tarmac road passing through the maize plantation up to the junction?  
 A. 7 km  
 B. 5.5 km  
 C. 8km  
 D. 9km
- Three of the following are social amenities found in Rungiri area. Which one is not?  
 A. Administrative office  
 B. School  
 C. Health centre  
 D. Recreational centre
- The settlement in Rungiri area can be described as \_\_\_\_\_  
 A. dense  
 B. linear  
 C. sparse  
 D. nuclear
- Which one of the following statements correctly describes the climate of Rungiri area?  
 A. It is cool and dry  
 B. It is cool and wet  
 C. It is hot and wet  
 D. It is hot and dry
- The main source of water for the residents of Waigiri town is .  
 A. the swamp  
 B. the bore hole  
 C. the pond  
 D. the river

7. What evidence shows that the town is an administrative centre?  
 A. Permanent buildings  
 B. School  
 C. Hospital  
 D. County commissioner's office
8. The following are effects of European settler farming in Kenya. Which one was a negative effect?  
 A. Setting up of industries  
 B. Introduction of exotic breeds  
 C. Exploitation of Africans  
 D. Formation of agricultural co-operatives
9. The following are methods of irrigation practiced in Kenya. Which one is used in Perkerra irrigation scheme?  
 A. Canal method  
 B. Furrow method  
 C. Drip method  
 D. Over head method
10. Below are roles played by political parties in a democracy. Which one is not?  
 A. Offering people freedom of choice.  
 B. Informing citizens about important issues  
 C. Ensuring that the ruling party does not abuse its power  
 D. Promoting disunity among the citizens
11. The following are responsibilities of children in the family except .  
 A. taking care of family property  
 B. helping their parents in doing some work at home  
 C. going to school to get education  
 D. provide security and protection for the family
12. Which one of the following is **not** a role of a Class prefect?  
 A. Ensures traditions and standards of the school are maintained  
 B. Act as a link between the pupils and the teachers.  
 C. Ensure school rules are obeyed  
 D. Inform the teachers of any problems the pupils may be having
13. Which one of the following types of migration occurs when pastoral communities migrate seasonally in search of water and pasture?  
 A. Emmigration  
 B. Urban - rural migration  
 C. Rural - rural migration  
 D. Urban - urban migration
14. Which one of the following is **not** a way of interaction of Kenyan communities today?  
 A. Trade  
 B. War  
 C. The media  
 D. Games and sports
15. Which one of these groups does not fit the Nilotic communities in Kenya?  
 A. Kipsigis, Pokot, Tugen  
 B. Maasai, Mijikenda, Pokomo  
 C. Marakwet, Njemps, Samburu  
 D. Iteso, Luo, Keiyo
16. Below are reasons for the migration of a certain community in Kenya from their homeland.  
 (i) **They wanted fertile farming land**  
 (ii) **Drought and famine**  
 (iii) **Need for pasture and water for their (livestock) animals**  
 (iv) **Spirit of adventure**  
 Which one of the combinations does not all belong to the Bantu?  
 A. i, ii  
 B. i, ii, iv  
 C. ii, iii, iv  
 D. i only
17. Which one of the following is **not** true on how HIV/ AIDS affects population growth in Kenya?  
 A. HIV/AIDS spreads faster among the youth  
 B. Mothers infected with HIV / AIDS are likely to infect their babies during birth  
 C. HIV /AIDS can be cured if treated early  
 D. Infected people are able to reproduce in a healthy manner
18. Three of the following methods of fishing are used in deep seas. Which one is not?  
 A. Net drifting  
 B. Long lining  
 C. Line fishing  
 D. Trawling
19. Which one of the following was not a reason for establishing settlement schemes in Kenya after independence?  
 A. To increase settlers farming land  
 B. Settle the landless  
 C. To reduce population pressure on land  
 D. To increase food production

20. Below are some conditions necessary for the growing a crop
- (i) *Deep and well- drained soils*
  - (ii) *High temperatures of between 24° and 28°*
  - (iii) *Shelter from strong winds*
  - (iv) *Annual rainfall of between 1500mm and 2000m*
  - (v) *Low altitudes of up to 750metres above sea level*
- The crop that grows under the conditions listed above is \_\_\_\_\_
- A. coffee
  - B. cocoa
  - C. tea
  - D. wheat
21. Who among the following explorers was sent by the Royal Geographical society to look for Dr. David Livingstone?
- A. John Speke
  - B. Vasco da Gama
  - C. Richard Burton
  - D. Henry M. Stanley
22. Three of the following were reasons of the coming of the Arabs to the East African Coast. Which one is **not**?
- A. To trade with the Coastal people
  - B. To spread Islam
  - C. To establish Swahili culture
  - D. To look for markets for their goods
23. Which one of the following is not an effect of revolution of the earth?
- A. change in the position of the mid-day sun
  - B. Occurrence of day and night
  - C. Occurrence of different seasons
  - D. Length of day and night
24. The following are characteristics of a type of traditional farming in Kenya .
- (i) *Land is cleared by burning the vegetation*
  - (ii) *Land is cultivated from season to season until decline of harvest*
  - (iii) *A farmer moves to another piece of land and cultivate*
  - (iv) *The farmer returns to the first one after two to three years*
- The characteristics listed above describe a traditional type of farming known as
- A. mixed farming
  - B. shift farming
  - C. fallowing
  - D. bush fallowing
25. Which one of the following is **not** a contribution of banana to the economy of Uganda?
- A. Source of food for many communities
  - B Facilitates rural-urban migration
  - C. Provides employment opportunities
  - D. Farmers earn income from the sale of bananas
26. Below are statements about a mineral in Kenya.
- (i) *It is mined at Kerio valley*
  - (ii) *Used in production of sulphuric acid*
  - (iii) *Manufacture of non- stick cooking pans*
  - (iv) *Manufacture of toothpaste*
- The mineral described above is \_\_\_\_\_
- A. limestone
  - B. flourspar
  - C. diatomite
  - D. gemstone
27. Which one of the following is **not** a role of a citizen in the electoral process?
- A. Electing responsible leaders
  - B. Promoting free and fair elections
  - C. Ensuring that leaders misuse their powers
  - D. Participating in elections once they attain the age of 18 years and above
28. Below are some reasons why a member of parliament may lose a parliamentary seat **except**
- A. if he or she is of sound mind
  - B. if it is proved that he/she is not a Kenyan
  - C. if imprisoned for six months or more
  - D. If declared bankrupt by a court of law
29. Which one of the following is **not** the work of administration police?
- A. Provide security for government offices
  - B. Make regular patrols in towns and residential areas to ensure security for citizens
  - C. Guide, direct and maintain order among people seeking services in government offices
  - D. They guard government buildings and property

Use the diagram below to answer question 30.

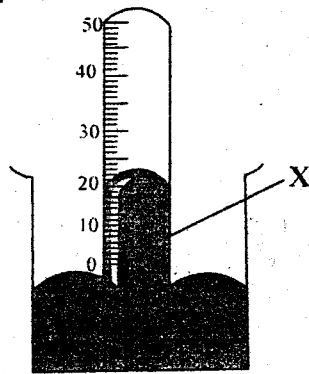

30. Which one of the following is found in the part marked X ?

- A. Mercury                      B. Air pressure  
C. Vacuum                      D. Alcohol

31. Which one of the following is **not** a social use of soil?

- A. Growing crops  
B. Decorating bodies  
C. Burying the dead  
D. Making the initiates numb

32. Which one of the following **does not** describe negotiation as a way of resolving conflicts?

- A. Selected person officially settles a disagreement  
B. There is a direct discussion between the parties involved  
C. At times the third party may be involved  
D. It helps the involved parties settle their differences

33. In which way of resolving conflict is a commission or an international body sought as a third party to help resolve the dispute?

- A. Enquiry                      B. Mediation  
C. Arbitration                      D. Conciliation

Use the diagram below to answer question 34.

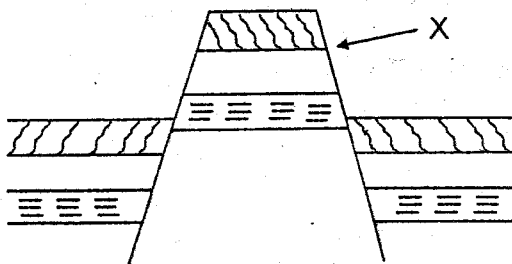

34. Which one of the following explains the process that has acted on the part labelled X?

- A. It has been pushed towards the centre by forces from both sides  
B. It has been pushed upwards by underground forces  
C. It has been pulled apart by tensional forces  
D. It has been formed as a result of Lava flow

35. Three of the following statements describe the social organization of the Khoikhoi. Which one does **not**?

- A. They painted pictures of their animals  
B. They were organized in clans  
C. They believed in a supreme being  
D. They celebrated festivals of the new moon

36. Which one of the following statements is **not** true about fishing in both Kenya and Japan?

- A. Kenya rears Tilapia, trout and mudfish  
B. Japan has a large fish market  
C. Both Kenya and Japan rely heavily on scientific farming  
D. Japan rears oysters, prawns, eels and trout

37. Which one of the following industries is correctly matched with the raw material it uses?

<u>Industry</u>	<u>Raw material</u>
A. Leather tanning	- Cotton
B. Vehicle assembly	- Scrap metals
C. Paper	- Stones
D. Cement	- Limestone

38. Below are reasons for establishing Jua Kali industries. Which one is **not**?

- A. To increase rural - urban migration  
B. To fulfil the government's policy  
C. To help Kenyans become self-employed  
D. To encourage the development of industries

39. Below are tourist attractions in Africa.

- (i) Valley of Kings  
(ii) Gedi ruins  
(iii) Nile cruises  
(iv) Table mountains  
(v) Berber villages

Which one of the following combinations is made up of tourist attractions in Egypt?

- A. ii and v                      B. i and iii  
C. iv and v                      D. iii and iv

40. Std 8 girls were discussing the qualities of a good citizen. Who among them gave a wrong answer? A good citizen \_\_\_\_\_

**Kingo:** Promotes patriotism

**Njoki:** Takes part in general elections

**Wahu:** Promotes Nepotism

**Mweru:** Is loyal to his / her country

- A. Mweru                      B. Wahu  
C. Kingo                      D. Njoki

41. Which one of the following terms does not describe the values of African socialism?

- A. Caring for one another  
B. Selfless  
C. Generosity  
D. Favouritism

42. Which one of the following is an economic reason that made the Europeans scramble for Africa?

- A. To protect the missionaries  
B. To settle surplus population  
C. To abolish slave trade  
D. To get markets for their goods

43. Who among the following was advised by chief Khama of the Ngwato?

- A. Samori Toure  
B. Lewanika  
C. Kabaka Mwanga  
D. Chief Mkwawa

44. Below are characteristics of a climatic region in Africa.

*(i) The annual range of temperature is high*

*(ii) Dust storms are common*

*(iii) Summers are dry*

The climatic region described above is\_

- A. Deserts                      B. Savanna  
C. Equatorial                  D. Mediterranean

Use the map of Africa below to answer questions 45-48

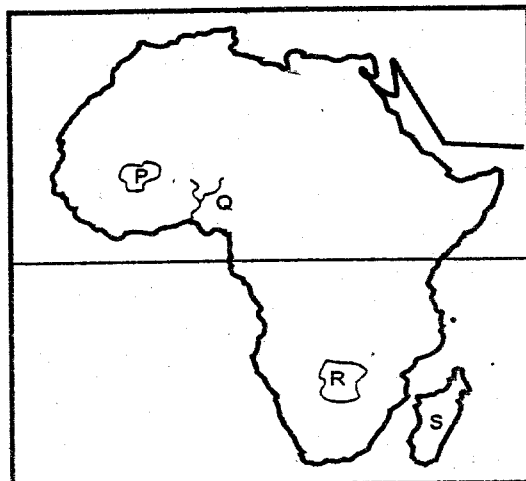

45. The physical feature marked P is

- A. El Djouf basin  
B. Adamawa highlands  
C. Bie Plateau  
D. Fouta Djallon plateau

46. The river project marked Q helped in the extraction of which one of the following minerals?

- A. Bauxite                      B. Petroleum  
C. Copper                      D. Gold

47. The town marked R is \_\_\_\_\_

- A. Pretoria                      B. Lusaka  
C. Gaborone                      D. Windhoek

48. The country Island marked S was colonized by the \_\_\_\_\_

- A. British                      B. Germans  
C. Portuguese                  D. French

49. The following are benefits of democracy in Kenya. Which one is not?

- A. People are treated unequally before the law  
B. Promotion of freedom  
C. Gives people the right to own property  
D. People have light to make decisions

50. Among the following are benefits of trade to Kenya's economy except

- A. source of foreign exchange  
B. creation of employment opportunities  
C. promotion of economic growth  
D. encourages people to move to urban centres

51. Three of the following are challenges facing tourism in Africa. Which one is not?

- A. Poaching  
B. Human - wildlife conflicts  
C. Good marketing of destinations  
D. Stiff competition from other tourist destinations

52. The average weather-condition of a place for a long period of time is

- A. humidity  
B. atmospheric pressure  
C. air pressure  
D. climate

53. The cause of soil erosion in North Eastern part of Kenya is \_\_\_\_\_

- A. deforestation  
B. overstocking  
C. monocropping  
D. up the slope cultivation

54. Which one of the following led the Hehe to resist colonization?

- A. Influence of Mkwawa's prophecy  
B. Representation in the legislative council  
C Harsh German rule  
D. Demand for white collar jobs

55. Three of the following are contributions of Julius Nyerere. Which one is **not**?
- He supported African liberation movements
  - He organized non-violent struggle
  - He negotiated for independence from colonialists
  - He built private schools to support education
56. The following are functions of Addis Ababa **except**
- it is an administrative centre
  - it is an industrial centre
  - it is a sea port
  - it is an educational centre
57. Three of the following are problems facing pastoral farming in Africa. Which one is **not**?
- Plenty and quality pasture
  - Harsh climatic conditions ~
  - Political boundaries
  - Diseases
58. Which one of the following climatic conditions favours the rearing of dairy animals?
- Plenty of sunshine
  - Hot and wet conditions**
  - Hot and dry conditions
  - Cool and wet conditions
59. The following contributes to the increase of road accidents. Which one does **not**?
- Unroadworthy vehicles
  - Careful drivers
  - Overspeeding
  - Ignoring traffic rules
60. Three of the following statements are true about the Organization of African Unity (O.A.U). Which one is **not** ?
- It has been transformed into the African Union (AU)
  - It helped liberate African countries
  - Its members were drawn from Independent African states
  - It was formed to help promote racialism
- Section II**  
**Christian Religious Education**
61. The first book of the Bible is also known as
- beginning
  - deliverance
  - messenger
  - poetry
62. Who among the following people helped the Israelites cross river Jordan?
- Moses
  - Noah
  - Jonah
  - Joshua
63. How old was Abraham when he was called by God to move from Haran to Canaan?
- 100 years
  - 75 years
  - 40 years
  - 90 years
64. The Israelites were to celebrate the Passover meal every year
- to mark their entry to the wilderness
  - in order to defeat their enemies
  - to remember God's saving power out of Egypt
  - because they had become God's chosen race
65. When Moses died on Mt. Pisgah, God buried him in the land of:
- Moriah
  - Cush
  - Moab
  - Sinai
66. God rejected the sons of one of the following Judges of Israel. Who was he?
- Gideon
  - Samson
  - Elon
  - Samuel
67. The following achievements refer to one of the Kings of Israel
- He was very courageous and he killed a lion**
  - He fought against the Philistines and Amalekites**
  - United all the 12 tribes of Israel**
- The king described is likely to be \_\_\_\_\_
- David
  - Saul
  - Solomon
  - Rehoboam
68. Which one of the following miracles was performed by prophet Elisha?
- He called for drought which lasted for 3½ years
  - He multiplied 20 loaves of bread and 100 prophets were fed
  - He healed 10 lepers and told them to be examined by the priests
  - He ran faster than a chariot which was carrying King Ahab
69. The prophet who called for "Justice to flow like a stream" was
- Amos
  - Joel
  - Micah
  - Hosea
70. When angel Gabriel appeared to Zachariah in the temple, he was:
- preaching
  - lamenting
  - burning incense
  - doubting the angel's word
71. When Joseph noted that Mary was expectant He decided to
- run away from home
  - inform Mary's parents
  - seek Zachariah's view
  - break the engagement

72. When Jesus started His ministry in Cana of Galilee, He was rejected in Nazareth and went to ( Luke 4: 16 - 30)  
 A. Jerusalem                      B. Jericho  
 C. Nain                                D. Capernaum
73. Which one of the following statements is a teaching of Jesus on revenge?  
 A. Make certain you do not perform religious duties in public to be seen  
 B. If someone takes you to court to sue you for your shirt, let him have your coat too  
 C. And When you pray, do not be like the hypocrites  
 D. Whoever is angry with his brother will be brought to trial
74. Which one of the following parables teaches that good Christians should produce good fruits in order to Inherit the kingdom of God?  
 A. Marriage bouquet  
 B. Barren fig tree  
 C. The sower  
 D. Talents and pounds
75. Before He was arrested, Jesus went to pray in the garden of Gethsemane (Mt. Olives) which is in the town of  
 A. Bethlehem                      B. Jericho  
 C. Bethany                         D. Nazareth
76. After how long did Jesus stay on earth after resurrection?  
 A. 40 days                         B. 60 days  
 C. 10 days                         D. 50days
77. Jesus Christ ascended to heaven at  
 A. Jerusalem                      B. Cana  
 C. Turbo                             D. Bethany
78. "There was a strong wind." The wind broke into tongues of fire," The tongues of fire landed on the disciples' heads. These events happened during the  
 A. baptism of Jesus -  
 B. transfiguration of Jesus  
 C. day of Pentecost  
 D. temptation of Jesus
79. St Paul the Apostle, after his conversion was called by God to preach the word of God to the \_\_\_\_  
 A. Jews                                B. Gentiles  
 C. Canaanites                      D. Nazarites
80. The duty that was given to Stephen during the early church was:  
 A. making tents  
 B. helping widows  
 C. working miracles  
 D. interpreting tongues
81. Who among the following characters had a vision at Joppa where he saw a large sheet being lowered to the earth?  
 A. Paul                                B. Tabitha  
 C. Aeneas                          D. Peter
82. Which one of the following words is not found in the Apostles creed?  
 A. Thy kingdom come  
 B. Belief In God  
 C. Forgiveness of sins  
 D. Belief in the Holy spirit
83. In traditional African communities children were taught their responsibilities mainly by  
 A. brothers                         B. friends  
 C. parents                         D. sisters
84. In some traditional African communities people worship under some trees because it  
 A. provides a good shade  
 B. is a quiet place  
 C. is a God's dwelling place  
 D. avoids inconveniences
85. Which one of the following is a rite of passage in traditional African society?  
 A. Baptism                         B. Initiation  
 C. Pregnancy                      D. Confirmation
86. Which one of the following is the best way for Christians to use their wealth?  
 A. Visiting game parks  
 B. Entertaining friends  
 C. Buying a nice car  
 D. Visiting homes for the orphans
87. Why was marriage highly valued in traditional African communities?  
 A. For procreation  
 B. For companionship  
 C. For recognition  
 D. To give room for divorce
88. When playing in the field James collected one hundred shillings note. John should  
 A. take the money to his parents  
 B. give the money to the game's teacher  
 C. keep the money in the pocket  
 D. give the money to a friend
89. Mwangi your friend is involved in stealing and you are the only witness. What would you do?  
 A. Keep quiet  
 B. Report it to his parents for correction  
 C. Blow a whistle  
 D. Advice him to return what he had stolen
90. Josphat, a std 8 boy finds his younger brother fighting with another boy from his class. What should Josphat do?  
 A. Beat the boy  
 B. Take the other boy to the police  
 C. Separate them  
 D. Beat his brother



# KAUNTI YA NYERI

## DARASA LA NANE - 2015



### KISWAHILI LUGHA

Muda: Saa 1 dakika 40

#### SOMA KWA MAKINI MAAGIZO YAFUATAYO

1. Umpewa kijitabu hiki cha maswali na karatasi ya kujibia. Kijitabu hiki kina maswali 50.
2. Ikiwa utataka kuandika chochote ambacho si jibu andika katika kijitabu hiki.
3. Ukisha chagua jibu lolote lionyeshe katika **KARATASI YA MAJIBU** na wala siyo katika kijitabu hiki cha maswali

#### JINSI YA KUTUMIA KARATASI YA MAJIBU

4. Tumia penseli ya kawaida
5. Hakikisha ya kwamba yafuatayo yameandikwa katika karatasi ya majibu:  
**NAMBAYAKO YAMTIHANI**  
**JINA LAKO**  
**JINA LASHULE YAKO**
6. Kwa kuchora kistari katika visanduku vyenye namba zinazokuhusu, onyesha namba yako kamili ya mtihani (yaani namba ya shule, na zile namba tatu zako wewe mtahiniwa) katika sehemu iliyotengwa mwanzo wa karatasi ya majibu.
7. Usitie alama zozote nje ya visanduku
8. Iweke safi karatasi yako ya majibu na usiikunje
9. Kwa kila swali 1-50 umpewa majibu manne. Majibu hayo yameonyeshwa kwa herufi A, B, C, D. Ni jibu MOJA tu kati ya hayo manne ni sahihi. Chagua jibu hilo
10. Kwenye karatasi ya majibu, jibu sahihi lionyeshe kwa kuchora kistari katika kisanduku chenye herufi uliyochagua kuwa ndilo jibu

#### Mfano

21. Kamilisha methali: Ukiona vyaelea \_\_\_\_\_
- A. vyaenda
  - B. vyaundwa
  - C. vyazima
  - D. vyaisha

Jibu sahihi ni B

Katika karatasi ya majibu

1 [A][B][C][D]  11 [A][B][C][D]  21 [A][B][C][D]  31 [A][B][C][D]  41 [A][B][C][D]

Katika visanduku vinavyoonyesha majibu ya swali 21, kisanduku chenye herufi B ndicho kilichochoywa kistari.

11. Chora kistari chako vizuri. Kistari chako kiwe cheusi na kisijitokeze nje ya kisanduku
  12. Kwa kila swali, chora kistari katika kisanduku kimoja tu kati ya visanduku vinne ulivyopewa
- Karatasi hii ya maswali ina kurasa 7 zilizopigwa chapa

**Soma vifungu vifuatavyo. Vina nafasi 1-15. Chagua jibu lifaalo zaidi kati ya vale uliyopewa kujazia kila pengo.**

Ngano hii 1 inamlenga 2 kutoka jamaa 3 mjini. Amesomeshwa sana 4 katika kabila 5 elimu 6. Anapangiwa 7 na 8 yake ambaye ni mwanamume katili 9 lolote 10 kwa mwanawe.

- |                     |                   |                    |                      |
|---------------------|-------------------|--------------------|----------------------|
| 1. A. zuri          | B. ngeni          | C. baya            | D. jipya             |
| 2. A. barobaro      | B. ghulamu        | C. mvulana         | D. banati            |
| 3. A. inayofahamika | B. inayofahamiana | C. inayofahamishwa | D. inayofahamufahamu |
| 4. A. pindi         | B. endapo         | C. ingawa          | D. lau               |
| 5. A. hii           | B. hili           | C. hizi            | D. hiyo              |
| 6. A. haithaminiwi  | B. haithamani     | C. haidhamini      | D. haiaminiki        |
| 7. A. kuoleshwa     | B. kuoza          | C. kuoleka         | D. kuozwa            |
| 8. A. ajuza         | B. wifi           | C. abu             | D. ahali             |
| 9. A. asiyeona      | B. akimwona       | C. anayeona        | D. atakayeona        |
| 10. A. ngeni        | B. njema          | C. zuri            | D. mbovu             |

Ukabila katika bara 11 nao 12 kila mahali. 13 utapata kuwa 14 kazi ni wale wenye elimu dhaifu au wanaotoa 15.

- |                       |                |                 |                 |
|-----------------------|----------------|-----------------|-----------------|
| 11. A hii             | B. hili        | C. hizi         | D. hivi         |
| 12. A. umekita mizizi | B. umelia ngoa | C. umepiga debe | D. umepiga kite |
| 13. A. Angalau        | B. Ihali       | C. Endapo       | D. Aghalabu     |
| 14. A. anayezipata    | B. wanayepata  | C. wanaozipata  | D. wanayopata   |
| 15. A. kasiraji       | B. kadhongo    | C. karadha      | D. kombozi      |

**Kuanzia swali la 16 mpaka 30. jaza kulingana na maagizo.**

16. Ni neno gani lisilotumika katika tashbihi?  
A. Ja  
B. Mithili ya  
C. Mathaian  
D. Kama
17. Kifawe gani chenye maana ya  
Aina ya panya mkubwa  
Kitabu kilichochapishwa  
A. Buku  
B. Kurasa  
C. Kichapio  
D. Tabu

18. Kitanda cha kukaushia kuni jikoni ni  
A. tanuri  
B. degi  
C. deste  
D. uchaga
19. Chagua vazi lisilo la jinsia zote mbili  
A. kocho  
B. deraya  
C. seruni  
D. jezi

20. Nomino gani isiyoonyesha kundi la watu fulani ?  
A. Mzengwe  
B. Kishazi  
C. Jopo  
D. Kilinge

21. Tumia takriri ifaayo.  
Mtoto huyu amepotoka kabisa. Hata akifanya kosa \_\_\_\_\_  
A. hakiri habari  
B. si hayati si mamati  
C. ni nadra na adimu  
D. ana asili na jadi

22. Kisawe cha ndoto ni \_\_\_\_\_  
A. chete  
B. gonezi  
C. luja  
D. ruiya

23. Rais kwa ikulu ni kama mchwa kwa \_\_\_\_\_  
A. kifukofuko  
D. koto  
C. kishirazi.  
D. pango .

24. Andika katika wingi  
Nyani amemla mkunga aliyevuliwa  
A. Nyani wamewala mkunga waliovuliwa  
B. Manyani wamewala mikunga waliovuliwa  
C. Wakunga waliovuliwa wameliwa na manyani  
D. Nyani wameila mikunga iliyovuliwa

25. Silaha ya kizamani ni  
A. kifaru  
B. nyambizi  
C. manati  
D. manowari

26. Kamilisha methali ifuatayo.  
Kuunguako ndiko  
A. kuteketeako  
B. kusimamako  
C. kuinamako  
D. kuinukako

27. Chagua sentensi yenye kivumishi cha idadi isiyo bayana  
A. Sisi tutayala matunda yote  
B. Sina shilingi kumi mfukoni  
C. Nyumba ya pili ilibomoka juzi  
D. Mkutano ulikuwa na watu kadhaa

28. Arafa, kitenzambali, kirudufu, na kipakatalishi ni katika baadhi ya \_\_\_\_\_  
A. msamiati wa teknolojia  
B. sehemu za rununu  
C. msamiati wa kompyuta  
D. msamiati wa mambo ya kisasa

29. Badilisha sentensi hii hadi wingi wenye O tamati.  
Kalenda ambayo inauzwa ni ya mwaka uliopita  
A. Kalenda iuzwayo ni ya miaka iliyopita  
B. Kalenda wanazouza ni za miaka zilizopita  
C. Kalenda wanazouza ni za miaka iliopita  
D. Kalenda ziuzwazo ni za miaka iliyopita

30. Habari yako?  
A. Mzuri  
B. Njema  
C. Jema  
D. Baya

**Soma taarifa hii kisha ujibu swali 31 - 40.**

Tatizo kubwa ambalo litakuwa katika taifa letu hivi karibuni ni hasara ya matibabu katika miaka michache ijayo. Wananchi wengi hapa nchini watakabiliwa na hali ngumu ya kudhibiti miili yao kutokana na maradhi mbalimbali hasa yale yatakayosababishwa na jinsi tunavyokula na kile tunachokula.

Kando na utapiamlo ambao sana sana huwashambulia walalahoi, walalaheri hasa ndio walio kwenye hatari kubwa ya kuugua maradhi ya moyo, kisukari na msukumo wa damu. Baadhi ya utafiti wa hali ya lishe na afya unaonyesha kuwa kuna uhusiano mkubwa sana wa maradhi na vyakula tunavyokula. Mwelekeo ambao wananchi wengi wa taifa hili wamechukua kuhusu chakula ni mbaya sana .

Sio siri kuwa chakula cha kiasili kama vile pure, muhogo, viazi vitamu, yugwa na mboga za majani hakina nafasi tena nyumbani kwetu. Watoto wetu pia hawataki kuviona vyakula vya aina hii kwani wanaviona kama vya kishamba na vya watu wasioendelea. Badala yake watoto wetu wamegeukia vyakula vyenye sukari, mafuta, na chumvi nyingi. Kwa mfano, leo mtoto wa kawaida tu atajipata akila mandazi, vitumbua, vibanzi, kaurkau, pipi na vingine vyenye mafuta na sukari nyingi. Mtoto hakosi kula mojawapo ya vyakula hivi zaidi ya mara mbili. Hatari iliyoje?

Kile ambacho hatujagundua ni kuwa vyakula hivi vyenye mafuta, sukari na chumvi nyingi ni hatari sana katika miili yetu na ndivyo husababisha maradhi ya moyo, mkimbio wa damu, kisukari, saratani na maradhi mengine mengi. Aidha vyakula vya viwandani ambavyo vimekoboewa ni hatari kwetu kwani husababisha maradhi ya kisukari. Kwa mfano, mchele na unga wa pakiti kutoka viwandani havina faida kwa miili yetu. Ukweli ni kwamba baada ya kula vyakula hivi, hatuli matunda na mboga za majani ambazo husaidia katika kuunda vitamini ambazo hukabiliana na maradhi mwilini.

Aidha matangazo katika vyombo vya habari yameharibu zaidi na kuchochea ulaji mbaya wa vyakula. Matangazo ya kuongezea kemikali kwenye vyakula yanapotosha na serikali yahitaji kuweka maisha ya wananchi wake mbele kuliko pesa. Si ajabu sasa katika taifa hili maradhi yanayowala watu sana yamegeuka kuwa ni saratani, shinikizo la damu, maradhi ya moyo na hata kisukari kimeingilia vijana.

Ni kwa nini sasa serikali isichukue jukumu la kuwaelimisha raia wake kuhusu chakula na afya? Jamani tuleni vizuri ili tuwe na afya na tuishi maisha marefu! Tamutamu na lawalawa ni kujichimbia kaburi la mapema.

31. Miaka isiyo mingi ijayo, nchi yetu itakumbwa na shida gani?  
 A. Ya kuthibiti hospitali nchini  
 B. Ya kukabiliana na uchaguzi  
 C. Ya kuwapa wananchi lishe bora  
 D. Ya kudhibiti hali ya afya nchini
32. Wananchi wengi hawatajiweza kutokana na \_\_\_\_  
 A. hali ya uzee  
 B. mazoea ya ulaji mbaya  
 C. ukosefu wa matibabu  
 D. hali ya njaa nchini
33. Watu walio kwenye hatari kubwa zaidi ya kuugua maradhi yatoakanayo na ulaji mbaya ni  
 A. wale wanaojiweza kifedha  
 B. jale wenye utapiamlo  
 C. wale waliokosa kusoma  
 D. wale masikini hohehahe
34. Ili kuepuka ugonjwa wa saratani tunahitaji kupunguza nini hasa katika lishe yetu?  
 A. Mboga na matunda  
 B. Vyakula vya kiasili  
 C. Vyakula vyenye sukari na chumvi nyingi  
 D. Vyakula vya mboga za majani
35. Ulaji wa vyakula vya viwandani vilivyokobolewa huchangia sana kusababisha ugonjwa wa  
 A. saratani  
 B. kisukari  
 C. utapiamlo  
 D. shinikizo la damu
36. Maradhi ya moyo au shinikizo la damu huenda yakasababishwa na \_\_\_\_  
 A. ukosefu wa vyakula vyenye mafuta  
 B. ulaji wa mboga nyingi za majani  
 C. vyakula vyenye mafuta mengi  
 D. vyakula vya viwandani vilivyokobolewa
37. Matangazo ya kemikali zinazotiwa kwenye chakula  
 A. yahitaji kutazamwa kwa undani na serikali  
 B. yaongezwe kwani huelimisha watu juu ya lishe bora  
 C. huletea serikali pesa nyingi kwa hivyo iendelee  
 D. hayana athari zozote katika mwenendo wetu wa kula
38. Kati ya vyakula hivi, ni kipi hasa cha kiasili?  
 A. Vibanzi  
 B. Nyama ya mkebe  
 C. Soda  
 D. Njugu karanga
39. Jukumu kubwa la serikali sasa ni \_\_\_\_  
 A. kueleemisha wananchi wote kuhusu afya na ulaji bora  
 B. kujenga hospitali nyingi za kukabiliana na wagonjwa  
 C. kupiga marufuku matangazo ya kemikali za kutia vyakula  
 D. kuweka akiba ya dawa za kutibu maradhi ya ulaji mbaya
40. Kichwa kifaacho zaidi taarifa hii ni  
 A. Mwenda pole hajikwai  
 B. Tahadhari kabla ya hatari  
 C. Cha mlevi huliwa na mgema  
 D. Haba na haba hujaza kibaba

**Soma kifungu kifuatacho kisha ujibu maswali 41 - 50.**

Ali alijiona sasa ni kijana barobaro. Akaona ni wakati wa kujichagulia mwenyewe kati ya makuruhu na ahsani. Jambo la mwanzo lililomjia akilini lilikuwa kutafuta njia ya kujitenga na aila yake. Labda siyo kujitenga kiasi cha ardhi na mbingu, lakini alitaka akae peke yake ili aweze kujiamulia atakalo bila ya kubughudhiwa na mja yeyote.

Alichoshwa kabisa na kazi za nyumbani. Mikono yake ilikuwa imeota sagamba kwa kamba ya kisima, na miguu yake sugu kwa kutafuta kuni kutoka mwituni. Tena, kulikuwa na kundi la mbuzi la kupelekwa malishoni na kuwawinga ndege kwenye konde la mpunga. Kilichomfika utosini ni yale matusi ya wavyele wake.

Ali alikuwa amekwisha amua kuondoka. Tatizo lilikuwa aelekee wapi? Ni katika hali hiyo ndipo ureda na shamrashamra za mjini zilipomjia. Alikumbuka kinagaubaga hali ilivyokuwa mjini wakati alipowahi kuuzuru.

Kila kitu cha mjini kilianisi. Alikumbuka kuwaona waliovalia mavazi ya kuanisi wakiwa kwenye magari ya kuvutia. Nyuso zao zilijaa bashasha na hapakuwa na shaka kuwa kwao neno "shida" lilikuwa ni msamiati ambao labda wangehitaji kamusi ili kubaini maana yake.

Mabustani ya starehe yalikuwa kila mahali. Muziki mwanana uliotoka huko ungeweza kuwatoa nyoka wote kutoka mapangoni mwao. Licha ya yote hayo kulikuwa pia na majumba ya ghorofa na ya fahari yaliothibitisha ukwasi.

Ali alipogutuka kutoka katika njozi yake alibaini jambo la kufanya mara moja. Angeifunga safari yake moja kwa moja hadi kwa sahibu yake.

Msafiri ni aliye bandarini. Ali alikuwa tayari kabisa kwani alikuwa amekwisha wauza mbuzi wake wawili na kupata nauli ya kumfikisha mjini.

Siku iliyofuata alifunga virago vyake tayari kwa safari ya kuelekea mjini. Mara alipofika kituo cha mabasi, alijipakia kwenye basi moja tayari kung'oa nanga. Roho yake ilianza kumdunda mara ilipoonekana wazi kuwa baada ya kusafiri kwa muda, atakuwa mjini.

Alivuta kumbukizi. Baada ya kutoka kituo cha mabasi palipaswa kuwa na kituo cha afya halafu angefuata njia kubwa iliyokuwa mkono wa kushoto. Kisha soko la samaki wakavu, halafu kitu kipi? Je, angepotea? Ukweli wa mambo ni kwamba, alianza kuwa na wahaka. Hata hivyo, alipiga moyo konde. Ukiyavulia maji nguo huna budi kuyaogea.

Wakati alipofika mjini hali ilikuwa kinyume cha matarajio. Alitafuta kituo cha afya. Hakukiona. Akiwa bado yuko katika hali ya kuhamanika alijikuta amepigwa kumbo na mtu asiyemjua. Alishikwa na jekejeke. Kila upande aliotazama aliwaona watu wamefurika furifuri, "Ah watu hawa wote wanaelekea wapi?" Alishangaa! Hakujua kabisa la kufanya. Lakini kitu kimoja alichokuwa na hakika nacho ni kwamba hakuweza kukiona kituo cha afya alichokuwa akikitafuta.

20. Nomino gani isiyoonyesha kundi la watu fulani ?  
A. Mzengwe  
B. Kishazi  
C. Jopo  
D. Kilinge

21. **Tumia takriri ifaayo.**

Mtoto huyu amepotoka kabisa. Hata akifanya kosa \_\_\_\_\_

- A. hakiri habari  
B. si hayati si mamati  
C. ni nadra na adimu  
D. ana asili na jadi

22. Kisawe cha ndoto ni \_\_\_\_\_

- A. chete  
B. gonezi  
C. luja  
D. ruiya

23. Rais kwa ikulu ni kama mchwa kwa \_\_\_\_\_

- A. kifukofuko  
D. koto  
C. kishirazi.  
D. pango .

24. **Andika katika wingi**

Nyani amemla mkunga aliyevuliwa

- A. Nyani wamewala mkunga waliovuliwa  
B. Manyani wamewala mikunga waliovuliwa  
C. Wakunga waliovuliwa wameliwa na manyani  
D. Nyani wameila mikunga iliyovuliwa

25. Silaha ya kizamani ni

- A. kifaru  
B. nyambizi  
C. manati  
D. manowari

26. **Kamilisha methali ifuatayo.**

Kuunguako ndiko

- A. kuteketeako  
B. kusimamako  
C. kuinamako  
D. kuinukako

27. Chagua sentensi yenye kivumishi cha idadi isiyo bayana

- A. Sisi tutayala matunda yote  
B. Sina shilingi kumi mfukoni  
C. Nyumba ya pili ilibomoka juzi  
D. Mkutano ulikuwa na watu kadhaa

28. Arafa, kitenzambali, kirudufu, na kipakatalishi ni katika baadhi ya \_\_\_\_\_

- A. msamiati wa teknolojia  
B. sehemu za rununu  
C. msamiati wa kompyuta  
D. msamiati wa mambo ya kisasa

29. **Badilisha sentensi hii hadi wingi wenye O tamati.**

Kalenda ambayo inauzwa ni ya mwaka uliopita

- A. Kalenda iuzwayo ni ya miaka iliyopita  
B. Kalenda wanazouza ni za miaka zilizopita  
C. Kalenda wanazouza ni za miaka iliopita  
D. Kalenda ziuzwazo ni za miaka iliyopita

30. Habari yako?

- A. Mzuri  
B. Njema  
C. Jema  
D. Baya

### **Soma taarifa hii kisha ujibu swali 31 - 40.**

Tatizo kubwa ambalo litakuwa katika taifa letu hivi karibuni ni hasara ya matibabu katika miaka michache ijayo. Wananchi wengi hapa nchini watakabiliwa na hali ngumu ya kudhibiti miili yao kutokana na maradhi mbalimbali hasa yale yatakayosababishwa na jinsi tunavyokula na kile tunachokula.

Kando na utapiamlo ambao sana sana huwashambulia walalahoi, walalaheri hasa ndio wao kwenye hatari kubwa ya kuugua maradhi ya moyo, kisukari na msukumo wa damu. Baadhi ya utafiti wa hali ya lishe na afya unaonyesha kuwa kuna uhusiano mkubwa sana wa maradhi na vyakula tunavyokula. Mwelekeo ambao wananchi wengi wa taifa hili wamechukua kuhusu chakula ni mbaya sana .

Sio siri kuwa chakula cha kiasili kama vile pure, muhogo, viazi vitamu, yugwa na mboga za majani hakina nafasi tena nyumbani kwetu. Watoto wetu pia hawataki kuviona vyakula vya aina hii kwani wanaviona kama vya kishamba na vya watu wasioendelea. Badala yake watoto wetu wamegeukia vyakula vyenye sukari, mafuta, na chumvi nyingi. Kwa mfano, leo mtoto wa kawaida tu atajipata akila mandazi, vitumbua, vibanzi, kaurkau, pipi na vingine vyenye mafuta na sukari nyingi. Mtoto hakosi kula mojawapo ya vyakula hivi zaidi ya mara mbili. Hatari iliyoje?

Kile ambacho hatujagundua ni kuwa vyakula hivi vyenye mafuta, sukari na chumvi nyingi ni hatari sana katika miili yetu na ndivyo husababisha maradhi ya moyo, mkimbio wa damu, kisukari, saratani na maradhi mengine mengi. Aidha vyakula vya viwandani ambavyo vimekoblewa ni hatari kwetu kwani husababisha maradhi ya kisukari. Kwa mfano, mchele na unga wa pakiti kutoka viwandani havina faida kwa miili yetu. Ukweli ni kwamba baada ya kula vyakula hivi, hatuli matunda na mboga za majani ambazo husaidia katika kuunda vitamini ambazo hukabiliana na maradhi mwilini.

Aidha matangazo katika vyombo vya habari yameharibu zaidi na kuchochea ulaji mbaya wa vyakula. Matangazo ya kuongezea kemikali kwenye vyakula yanapotosha na serikali yahitaji kuweka maisha ya wananchi wake mbele kuliko pesa. Si ajabu sasa katika taifa hili maradhi yanayowala watu sana yamegeuka kuwa ni saratani, shinikizo la damu, maradhi ya moyo na hata kisukari kimeingilia vijana.

Ni kwa nini sasa serikali isichukue jukumu la kuwaelimisha raia wake kuhusu chakula na afya? Jamani tuleni vizuri ili tuwe na afya na tuishi maisha marefu! Tamutamu na lawalawa ni kujichimbia kaburi la mapema.



41. Kujichagulia makuruhu na ahsani kulingana na muktadha ni
- kutochagua bichi na bivu.
  - kuchagua wema na ubaya
  - kuchagua kati ya uhai na kifo
  - kuchagua mambo yasiyokera
42. Neno kumbukizi katika muktadha wa kisa hiki ni
- mawazo yaliyompita akilini kama ndoto
  - vitu murua vya wakati wowote
  - fikra zinazopita akilini mwa kiumbe
  - mambo ya kidhahania au ya kweli
43. Msafiri ni aliye bandarini ina maana \_\_\_\_
- msafiri ni aliye melini
  - ni vizuri kujitayarisha mapema kwa lolote tufanyalo
  - msafiri akisafiri huenda bandarini
  - msafiri na bandari ni sawa
44. Kufika utosini kwa muktadha wa kifungu ni:
- mambo yalikuwa yamemzonga
  - mambo hayakuwa yamefika mwisho
  - mambo hayakuwa na mwelekeo
  - mambo yalimfika kichwa .
45. Ali alitarajia maisha ya aina gani mjini?
- Maisha yasiyo na kelele yoyote
  - Maisha yasiyo na buraha na anasa
  - Maisha ya kujikwatua kwa sifa
  - Maisha yenye buraha si kuduchu
46. Mikono ya Ali iliota sagamba kwa sababu
- ya kuchota maji kwa kata kisimani
  - ya kuburuta maji
  - ya kuvuta maji kutoka kisimani
  - ya kubeba maji kutoka kisimani
47. Kwa nini alipata hali ya mjini ni tofauti?
- Matarajio yalitumbukia nyongo
  - Mabustani yalikuwa mengi
  - Watu furifuri walikuweco
  - Alipigwa kumbo na mtu asiyemjua
48. Mafunzo yanayotokana na kifungu ni
- Tuishi maisha yasiyokuwa ya ndoto
  - Mjini kuna shida kama mashambani
  - Ali ni kijana asiye na dosari
  - Kumbukumbu ni wazo bora
49. Maana ya neno kumbo ni
- mkusanyiko wa watu wengi
  - mkusanyiko wa fikra
  - msukumo wa ghafla
  - msukumano wa watu wengi
50. Mada mwafaka inayofaa kifungu hiki ni
- Masaibu ya Ali
  - Masahibu ya Ali
  - Wahaka wa Ali
  - Ziara ya Ali

# NYERI COUNTY SECOND EXAM



## STANDARD EIGHT - 2015



Time: 2hrs

### MATHEMATICS

#### READ THESE INSTRUCTIONS CAREFULLY

1. You have been given this question booklet and a separate answer sheet. The question paper contains 50 questions.
2. Do any necessary rough work in this booklet.
3. When you have chosen your answer, mark it on the ANSWER SHEET, not in this question booklet.

#### HOW TO USE THE ANSWER SHEET

4. Use an ordinary pencil only.
5. Make sure you have written on the answer sheet.

YOUR INDEX NUMBER

YOUR NAME

NAME OF YOUR SCHOOL

6. By drawing a **dark line inside the correct numbered boxes** mark your full index number (i.e. School Code Number and the three-figure Candidate's Number) in the grid near the top of the answer sheet.
7. Do not make any marks outside the brackets [ ].
8. Keep the sheet as clean as possible and **DO NOT FOLD IT**.
9. For each of the questions 1-50 four answers are given. The answers are lettered **A, B, C, D**. In each case only **ONE** of the four answers is correct. Choose the correct answer.
10. On the answer sheet the correct answer is to be shown by drawing a dark line inside the box in which the letter you have chosen is written.

**Example:-**

**In the question paper.**

4. Change three thousand kilometres into hectometres

- A. 3
- B. 300
- C. 30
- D. 0.3

The correct answer is B. (300).

**On the answer sheet**

**4.** [A] [~~B~~] [C] [D]

**14.** [A] [B] [C] [D]

**24.** [A] [B] [C] [D]

**34.** [A] [B] [C] [D]

In the first set, the box with the letter **D** printed in it is marked.

11. Your dark line **MUST** be within the bracket.
12. For each question **ONLY ONE** bracket is to be marked in each of four brackets.

This Question Paper consist of 8 printed pages.

1. Which of the following numbers is seventy seven million seventy thousand and thirteen hundredths?  
 A. 7070070.13  
 B. 77070000.13  
 C. 77007000.013  
 D. 7770000.013
2. What is the value of  $7(3^2 + 4^2) + 49 \div 7$   
 A. 32  
 B. 182  
 C. 224  
 D. 74
3. By how much is the total value of digit 6 less than the total value of 5 in this number 7503641?  
 A. 499400  
 B. 500600  
 C. 100000  
 D. 100
4. Write 82822882 in words.  
 A. Eighty two thousand eight hundred and twenty two and eight hundred and eighty two.  
 B. Eighty two million eight hundred and twenty two thousand eight hundred and eighty two.  
 C. Eighty two million eight hundred and twenty two eight hundred and eighty two  
 D. Eight hundred and twenty eight thousand eight hundred and twenty two .
5. Construct triangle JKF in which JK = 7cm, KF = 6cm. Measure angle JKF =  $110^\circ$ . Draw a circle touching the vertices. What is the length of its radius?  
 A. 5cm  
 B. 5.4cm  
 C. 6.1cm  
 D. 6.5cm
6. What is the product of edges, faces and vertices of a square based pyramid?  
 A. 200  
 B. 18  
 C. 270  
 D. 160
7. The following are properties of quadrilaterals.  
 (i) All sides are equal  
 (ii) Diagonals are equal in length  
 (iii) Diagonals are perpendicular bisectors  
 (iv) Diagonals are not equal  
 (v) All angles are equal  
 (vi) Opposite angles are equal  
 (vii) Has one pair of parallel lines  
 (viii) All interior angles add upto  $360^\circ$   
 Which properties are for a trapezium?  
 A. i, iii, iv  
 B. iv, v, vi  
 C. iv, vii, viii  
 D. ii, iii, vii
8. What is the place value of digit 8 after working out  $0.0784 \div 28$   
 A. Thousandths  
 B. Tens  
 C. Ten thousandths  
 D. Hundredths
9. A salesman earns a salary of sh 9,500 per month. He is also paid a commission of 8% on goods worth above sh.150,000. In one month he received a total of sh 29,500. How much was the sales he sold?  
 A. sh. 320000  
 B. sh. 250000  
 C. sh. 400000  
 D. sh. 120000

10. Work out:

$$2\frac{2}{3} \text{ of } 3\frac{3}{5} + 5\frac{3}{5} + 1\frac{1}{3} - 1\frac{1}{5}$$

- A.  $2\frac{5}{6}$
- B.  $6\frac{2}{5}$
- C.  $5\frac{4}{5}$
- D.  $9\frac{2}{15}$

11. Kareb has 35 oranges. His sister Janet has 14 oranges less than Kareb. Express Janet's oranges as a percentage of the total.

- A. 58.33%
- B. 62.5%
- C. 37.5%
- D. 60%

12. Simplify:

$$\frac{5(ab + a) - 2(3a + 2ab)}{3(a + b) + 2ab}$$

- A.  $\frac{9ab - a}{3a + 3b + 2ab}$
- B.  $\frac{ab + a}{3a + 3b + 2ab}$
- C.  $\frac{ab - a}{3a + 3b + 2ab}$
- D.  $\frac{9ab + a}{3a + 3b + 2ab}$

13. Three taps are used to fill a tank while the fourth one is used to discharge water from the tank. The first tap takes 3mins, the second 4mins and the third one takes 5min to fill the tank. The fourth tap discharges the tank in 5mins. If the tank is empty and the four taps are opened at the same time, how long would it take the tank to be full?

- A.  $1\frac{5}{7}$  min
- B.  $7\frac{1}{12}$  min
- C.  $4\frac{7}{60}$  min
- D.  $5\frac{1}{7}$  min

14. Below is a parallelogram MNOP. Calculate the size of angle OPM.

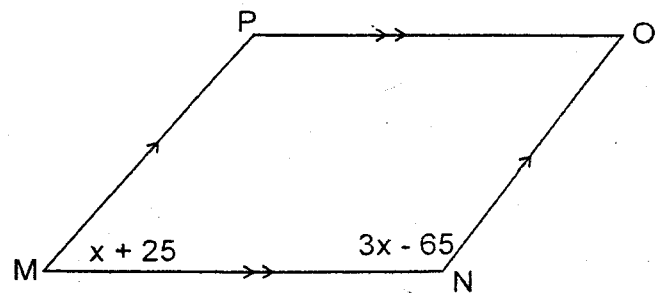

- A.  $100^\circ$
- B.  $80^\circ$
- C.  $90^\circ$
- D.  $165^\circ$

15. If  $a:c=5:4$  and  $c:b=8:1$ , find  $a : b : c$

- A. 5:4:3
- B. 10:1:8
- C. 5:12:4
- D. 3:16:20

16. Evaluate, and give your answer to 2 decimal places:

$$1.2 \times 0.12 + (1.32 + 0.102 \div 0.06)$$

- A. 3.164
- B. 3.16
- C. 3.17
- D. 23.84

17. The cash price of a machine is sh12000.

The hire purchase price is 25% more than the cash price. Mwaura bought it on hire purchase. He paid a deposit of sh2750. The rest was paid in monthly instalments. If each instalment was sh1750. How long did he take to pay?

- A. 5 months
- B. 7 months
- C. 6 months
- D. 9 months

18. Jimmi drove from town A to B at a speed of 30km/h, and then back at a speed of 40km/h. If he took a total of  $3\frac{1}{2}$ hrs, find the distance between town A and B.

- A. 70 km
- B. 60km
- C. 30km
- D. 40km

19. A business lady borrowed sh. 80000 in a bank that charged her a compound interest at the rate of  $6\frac{1}{2}\%$  per annum. How much interest did she pay at the end of 20 months?

- A. sh. 5200 .
- B. sh. 88892
- C. sh. 3692
- D. sh. 8892

20. Find the next number in the sequence

8, 27, 125, 343, \_\_\_\_\_

- A. 729
- B. 1728
- C. 1000
- D. 1331

21. The average weight of 6 girls is 41.4kg. Five of them weigh 36.5kg, 45.2kg, 38.6kg, 40.2kg and 42.4kg. Calculate the median weight of the six girls.

- A. 41.3kg
- B. 42.4kg
- C. 40.2kg
- D. 82.6kg

22. A circular room of diameter 28m was laid with a square carpet. Calculate the area of the room which is not covered by the carpet.

- A.  $420\text{m}^2$
- B.  $224\text{m}^2$
- C.  $384\text{m}^2$
- D.  $296\text{m}^2$

23. Calculate the volume of the figure below in cubic metres (Give your answer to three decimal places) (Take  $\pi = \frac{22}{7}$ )

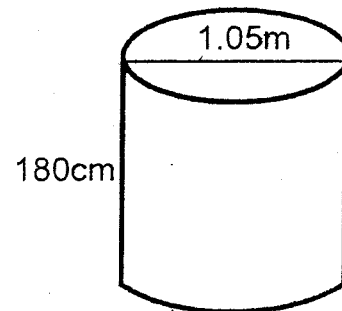

- A.  $15.590\text{m}^3$
- B.  $43.659\text{m}^3$
- C.  $1.559\text{m}^3$
- D.  $4365.900\text{m}^3$

24. Calculate the circumference of a circle whose area is  $38.465\text{cm}^2$  (Take  $\pi = 3.14$ )

- A. 21.98cm
- B. 31.34cm
- C. 18.74cm
- D. 24.72cm

25. The figure below is an open cubical container. If it is constructed using metal sheets, how much material is needed to construct it?

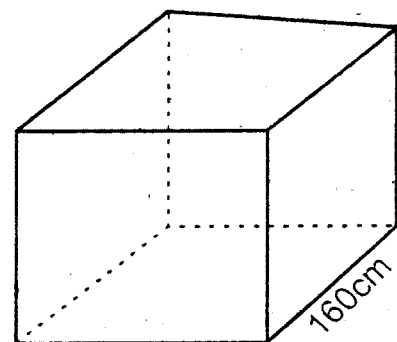

- A.  $153600\text{cm}^2$
- B.  $128000\text{cm}^2$
- C.  $179000\text{cm}^2$
- D.  $102400\text{cm}^2$

26. Calculate the area of the figure below.

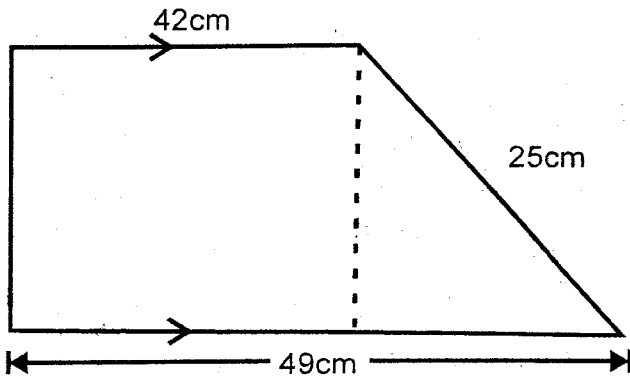

- A.  $1137.5\text{cm}^2$
- B.  $318.5\text{cm}^2$
- C.  $1092\text{cm}^2$
- D.  $2058\text{cm}^2$

27. A water tank in a shape of a cuboid measures 22m by 14m by 16m. 10% of the water was used each day for 2 consecutive days. If the water was full at the start of the first day, what amount of water in litres was in the tank by the end of the second day?

- A. 394240
- B. 395650
- C. 373290
- D. 3991680

28. In the figure below line PH is parallel to ST. Line PS = PO = PR. Angle SPR =  $48^\circ$  and PQH is a straight line. What is the size of angle RQH?

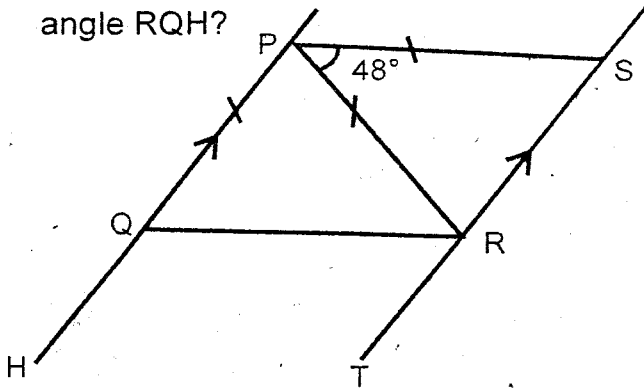

- A.  $66^\circ$
- B.  $114^\circ$
- C.  $123^\circ$
- D.  $57^\circ$

29. Shem bought a plot for  $\frac{1}{4}$  million. He later sold it at a loss of 5%. How much did he sell it?

- A. sh. 237,500
- B. sh. 1250000
- C. sh. 125000
- D. sh. 475000

30. Which of the following measurements cannot be used to draw a right angled triangle?

- A. 1.5cm, 2cm, 2.5cm
- B. 7cm, 12cm, 13cm
- C. 5cm, 12cm, 13cm
- D. 9cm, 12cm, 15cm

31. Koech ran round the field below thrice. What distance did he cover in km?

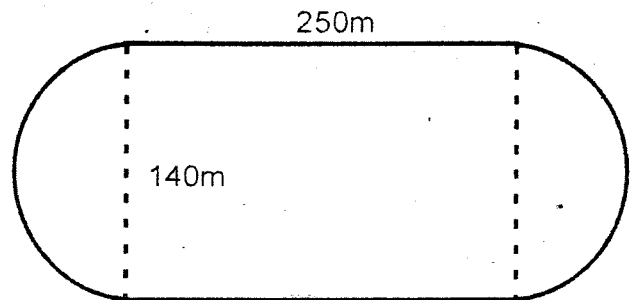

- A. 940km
- B. 2.82km
- C. 0.94km
- D. 0.28km

32. David bought kerosene for selling and put it in a rectangular tank measuring 80cm long by 60cm wide by 50cm high. On the way,  $\frac{1}{5}$  of the kerosene spilt due to the potholes on the road. What was the depth of the kerosene that remained in the tank?

- A. 38cm
- B. 50cm
- C. 40cm
- D. 48cm

33. Calculate the width of the figure below.

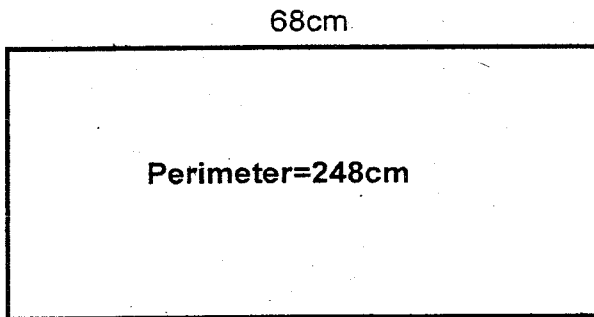

- A. 136cm  
 B. 124cm  
 C. 112cm  
 D. 56cm
34. Calculate the area of the figure below if the area of the triangle is  $54\text{cm}^2$  (Take  $\pi=3.14$ )

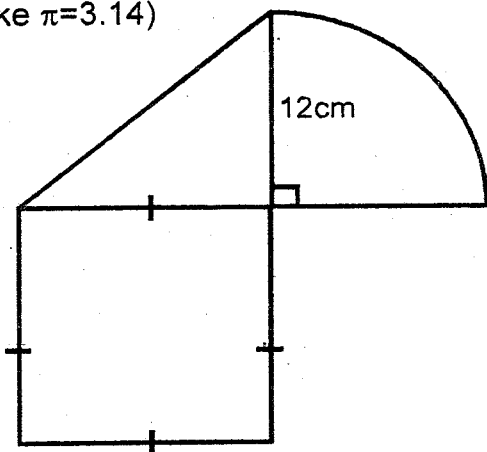

- A.  $248.04\text{cm}^2$   
 B.  $194.58\text{cm}^2$   
 C.  $219.34\text{cm}^2$   
 D.  $187.42\text{cm}^2$
35. A water pipe has a radius of  $8.61\text{cm}$  and a length of  $35\text{cm}$ . Calculate its surface area
- A.  $54.12\text{cm}^2$   
 B.  $2127.1866\text{cm}^2$   
 C.  $8154.531\text{cm}^2$   
 D.  $1894.2\text{cm}^2$

The table below shows the types and numbers of sodas sold by a trader on a certain day.

Sprite	Stoney	Fanta	Krest	Coke
42	62	64	—	40

36. The information was put in a pie -chart. If the angle representing coke was  $48^\circ$ . How many krest sodas were sold on that day?
- A. 300  
 B. 92  
 C. 110  
 D. 76
37. In year 2000, the total Mathematics lessons in a week added up to 4hrs 40min. This time was decreased in the ratio 4:7 in year 2015. Find the new total duration.
- A. 2hrs 10min  
 B. 8hrs 10min  
 C. 101hrs 9min  
 D. 2hrs 40min
38. Simplify the following inequality  $2\frac{3}{4}x - 6 < \frac{1}{2}x + 5 + x$
- A.  $x > 3\frac{5}{13}$   
 B.  $x < 3\frac{5}{13}$   
 C.  $x < 8\frac{4}{5}$   
 D.  $x > 8\frac{4}{5}$
39. Wambui deposited sh 60,000 in a bank that paid simple interest at the rate of 4%. After how long did the money yield an interest of sh. 8,400?
- A. 3yrs  
 B. 7yrs  
 C.  $3\frac{1}{2}$ yrs  
 D. 6yrs

40. Temperature in a liquid was  $20^{\circ}\text{C}$ . It was heated at the rate of  $9^{\circ}\text{C}$  per minute for 15 min and then allowed to cool at the rate of  $3^{\circ}\text{C}$  per minute for 8min. What was the final temperature of the liquid?

- A.  $131^{\circ}\text{C}$
- B.  $155^{\circ}\text{C}$
- C.  $135^{\circ}\text{C}$
- D.  $27^{\circ}\text{C}$

41. John made a wire triangular prism as shown below. What was the total length of the wire used?

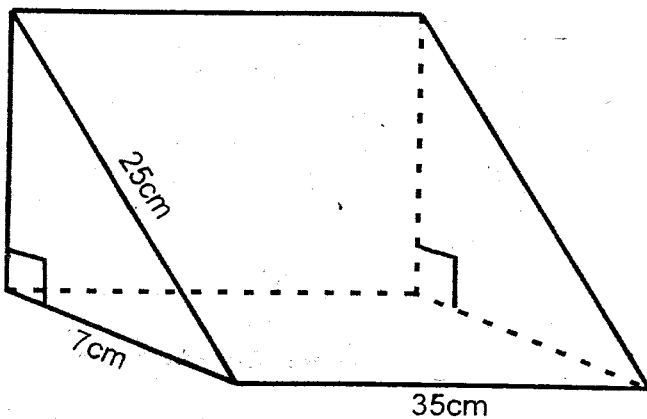

- A. 2940
- B. 67
- C. 207
- D. 217

42. Rachel paid sh. 35000 for a TV set after getting a discount of  $12\frac{1}{2}\%$ . How much more would she have paid had she been given a discount of 10%?

- A. sh 36000
- B. sh 1000
- C. sh 40000
- D. sh 4375

43. A river is represented by a length of 1.9cm on a map. What is the real length of the river in kilometres if the scale used is 1:3000000?

- A. 570000
- B. 57000

C. 0.57

- D. 5.7

44. Njeru bought 300 rabbits whose average weight was 1.2kg. The buying price per kilogram was sh 150. He later sold the rabbits at sh 180 per kg. What was his percentage profit?

- A. 80%
- B. 25%
- C. 20%
- D. 30%

45. The volume of the figure below is  $4250\text{cm}^3$ . Calculate the base of its cross section.

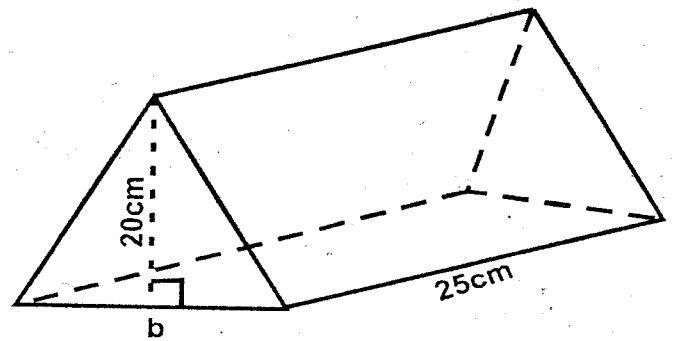

- A. 17 cm
- B. 15cm
- C. 23cm
- D. 13cm

46. A rectangular water tank which is 8m long and 6m wide holds 14400 litres of water when full. What would be the depth of the water when it is  $\frac{2}{3}$  full?

- A. 5m
- B. 3m
- C. 2m
- D. 0.2m



47. Calculate the distance round the figure below in Dm.

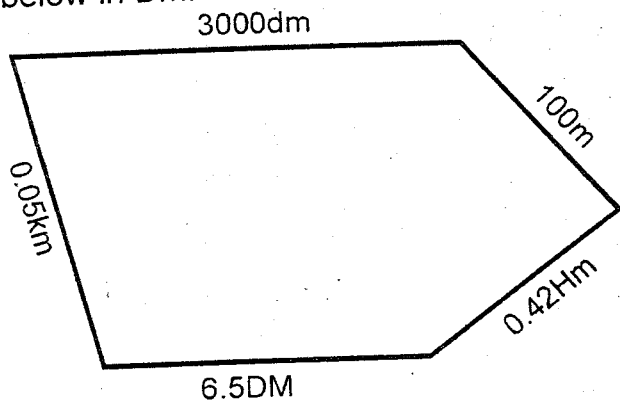

- A. 55.71dm
- B. 28.7Dm
- C. 28.5dm
- D. 55.7Dm

48. A train left Kisumu at 2308hrs on Wednesday. It took 14hrs 12min to reach Mombasa. At what time and day did it reach Mombasa in 12hrs clock?

- A. Wednesday 1.20pm
- B. Wednesday 1320hrs
- C. Thursday 1.20 pm
- D. Thursday 1.20 am

**The table shows inland postal charges in a post office.**

Type of article	Mass	Charges
Letters upto 20g	Not over 50g	20.00
	Not over 100g	23.00
	Not over 250g	29.00
	Not over 500g	43.00
	Not over 1 kg	112.00
	Not over 1.5kg	130.00
Post cards	Single card each	18.00
Aerogrammes	Single form	26.00

49. Lanet sent 3 letters, one to his son weighing 405g, one to his daughter weighing 504g and another one to his wife weighing 1300g. He also sent two aerogrammes and a post card to his business partners. He paid using a sh 500 note. How much should he add to be given a balance sh 150?

- A. sh 138
- B. sh 362
- C. sh 12
- D. sh 22

**The graph below shows Mworia's journey by bicycle from Mlolongo to Machakos. The distance between the two towns is 40km. He had a puncture and stopped for 30 minutes to mend it.**

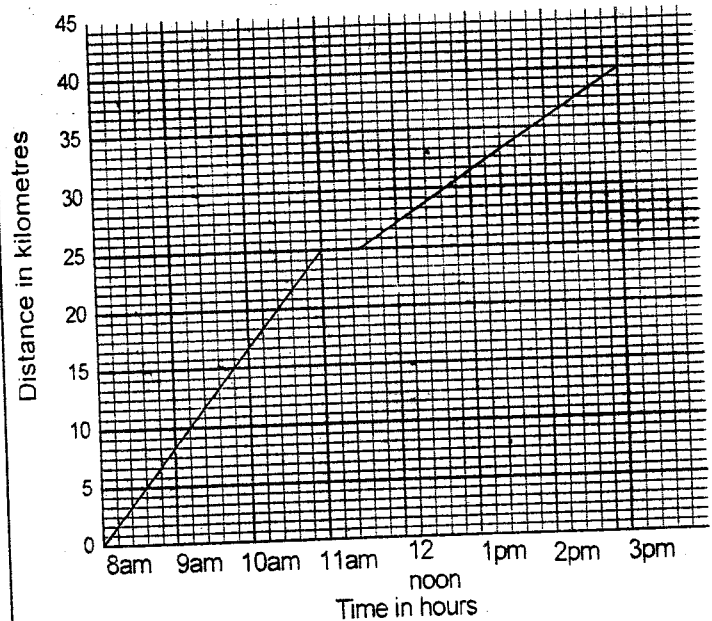

50. After mending the puncture, at what speed did Mworia cycle?

- A. 3km/hr
- B. 5km/hr
- C.  $8\frac{1}{3}$ km/hr
- D.  $4\frac{2}{7}$ km/hr

**NYERI COUNTY SECOND EXAM**  
**STANDARD EIGHT-2015**  
**MARKING SCHEME**

**8**

MATHS		ENGLISH		KISWAHILI		SCIENCE		SOCIAL STUDIES & C.R.E		
1. B	26. C	1. B	26. D	1. A	26. A	1. B	26. C	1. A	31. A	61. A
2. B	27. D	2. A	27. C	2. D	27. D	2. C	27. B	2. B	32. B	62. D
3. A	28. B	3. C	28. A	3. A	28. A	3. A	28. C	3. D	33. B	63. B
4. B	29. A	4. C	29. A	4. C	29. D	4. A	29. A	4. C	34. B	64. C
5. B	30. B	5. D	30. A	5. B	30. B	5. D	30. A	5. C	35. D	65. C
6. A	31. B	6. B	31. C	6. A	31. D	6. C	31. D	6. C	36. C	66. D
7. C	32. C	7. B	32. C	7. D	32. B	7. B	32. B	7. D	37. D	67. A
8. C	33. D	8. A	33. B	8. C	33. A	8. C	33. B	8. C	38. A	68. B
9. C	34. A	9. A	34. A	9. A	34. C	9. C	34. D	9. A	39. B	69. A
10. D	35. D	10. A	35. D	10. C	35. B	10. A	35. B	10. D	40. B	70. C
11. C	36. B	11. B	36. A	11. B	36. C	11. C	36. B	11. D	41. D	71. D
12. C	37. D	12. C	37. A	12. A	37. A	12. D	37. A	12. A	42. D	72. D
13. A	38. C	13. B	38. D	13. D	38. D	13. A	38. A	13. C	43. B	73. B
14. A	39. C	14. D	39. B	14. C	39. A	14. C	39. B	14. B	44. D	74. B
15. B	40. A	15. B	40. C	15. B	40. B	15. B	40. D	15. B	45. A	75. A
16. B	41. D	16. C	41. A	16. A	41. B	16. A	41. B	16. C	46. A	76. A
17. B	42. B	17. B	42. B	17. A	42. C	17. B	42. C	17. C	47. C	77. D
18. B	43. D	18. C	43. C	18. D	43. B	18. D	43. C	18. C	48. D	78. C
19. D	44. C	19. A	44. B	19. A	44. A	19. A	44. B	19. A	49. A	79. B
20. D	45. A	20. D	45. C	20. B	45. D	20. C	45. D	20. B	50. D	80. B
21. A	46. D	21. B	46. A	21. A	46. A	21. C	46. B	21. D	51. C	81. A
22. A	47. D	22. C	47. C	22. D	47. A	22. D	47. B	22. C	52. D	82. A
23. C	48. C	23. D	48. A	23. C	48. B	23. A	48. A	23. B	53. B	83. C
24. A	49. C	24. D	49. B	24. B	49. C	24. B	49. D	24. D	54. C	84. C
25. B	50. D	25. A	50. D	25. C	50. A	25. A	50. A	25. B	55. D	85. B
								26. B	56. C	86. D
								27. C	57. A	87. A
								28. A	58. D	88. B
								29. B	59. B	89. D
								30. A	60. D	90. C



# KAUNTI YA NYERI

## DARASA LA NANE-2015



**SEHEMU B:**  
**KISWAHILI: INSHA**

<b>JINA LAKO</b>	
<b>JINA LA SHULE YAKO</b>	
<b>NAMBARI YAKO</b>	

### SOMA MAAGIZO HAYA KWA MAKINI

1. Kwenye nafasi zilizoachwa hapo juu andika namba yako kamili ya mtihani, jina lako na jina la shule yako.
2. Soma kichwa cha insha kwa makini na uandike insha yako kwenye nafasi ulioachiwa.

**KISWAHILI: INSHA  
FUNGUA UKURASA**



# NYERI COUNTY SECOND EXAM

STANDARD EIGHT - 2015

8

002

**SECTION B:  
ENGLISH: COMPOSITION**

TIME: 40 MIN

YOUR NAME	
NAME OF YOUR SCHOOL	
INDEX NO.	

**READ THESE INSTRUCTIONS CAREFULLY**

1. In the spaces given above write your full index number, your name and name of your school
2. Read the heading of the composition carefully and write your composition on the lines provided.

**ENGLISH : COMPOSITION  
TURN OVER**

