

BIOLOGY

DISTRICTS SAMPLED AND COMPILED.

1. NAIROBI SCHOOLS
2. STAREHE BOYS CENTER
3. MANGU HIGH SCHOOL
4. ALLIANCE GIRLS HIGH SCHOOL
5. HOMABAY
6. RACHUONYO
7. MIGORI
8. UGENYA/UGUNJA
9. KISUMU WEST
10. MATUNGU
11. BUTERE
12. KAKAMEGA EAST
13. NYATIKE
14. KHWISERO
15. TRANS NZOIA WEST
16. TRANSMARA
17. KAKAMEGA NORTH
18. MUMIAS

TOPICS HIGHLIGHTED

1. Classification I & II.....4

2. The cell – structure & functions of organelles.....5

3. Cell physiology – osmosis, diffusion and active transport.....9

4. Nutrition in (a) plants (b) animals.....13

5. Transport in (a) plants (b) animals.....24

6. Gaseous exchange in (a) plants (b) animals.....30

7. Respiration.....34

8. Excretion and homeostasis.....37

9. Ecology.....45

10. Reproduction in (a) plants (b) animals.....53

11. Growth and development in (a) plants (b) animals.....61

12. Genetics.....68

13. Evolution.....75

14. Irritability and sensitivity in (a) plants (b) animals.....77

15. Support and movement in (a) plants (b) animals.....82

SECTION I & II QUESTIONS

- This section deals with paper one and two questions. In paper one you will find simple questions requiring simple answers, single answer and/or a sentence.
- In paper two structured data based questions and essay questions.

1. Classification I &II

1. Name **two** classes of phylum arthropoda with cephalothorax.
2. List any **three** distinguishing features of class mammalia.
3. Give **two** characteristics that distinguish scientific names of organisms from the ordinary names
4. (a) In which kingdom do bacteria belong?
(b) Give any **two** benefits of bacteria to man
5. Name the phylum whose members possess notochord
6. The diagram below represents a bread mould:-

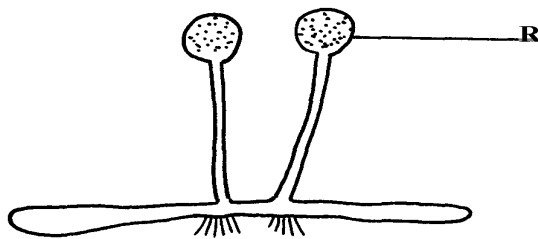

- (a) Identify the kingdom to which the organism belongs:-
7. Give a reason why no moulting occurs during the adult stages of insects
8. Name the branch of Biology that deals with the study of animals
9. State **four** ways in which some Fungi are beneficial to human
10. During a class practical form four students came across a plant whose flower floral parts were in multiples of fours and fives. To which sub-division and class does the plant belong?
11. A student caught an animal which had the following characteristics:-
 - Body divided into two parts
 - Simple eyes
 - Eight legs
 - The animal belongs to the class
12. The diagram below represents a bread mould.

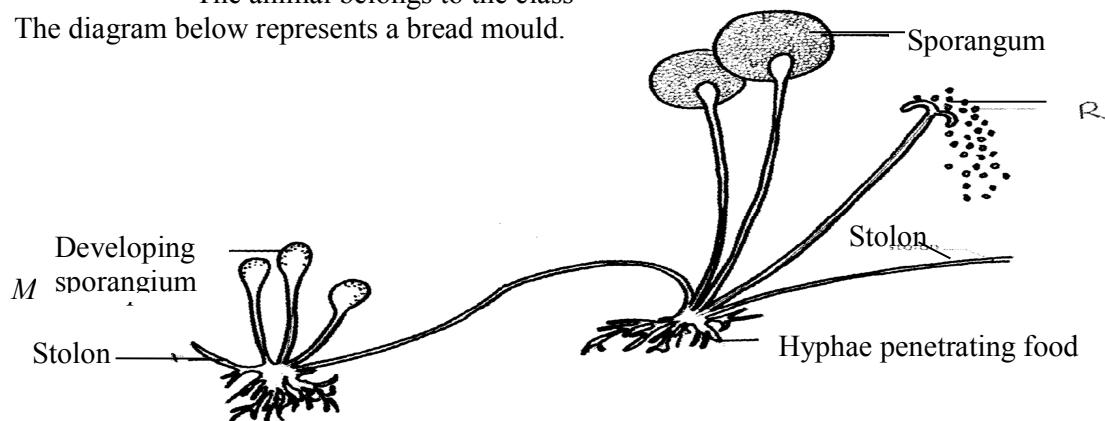

- (a) (i) Name the Kingdom to which bread mould belongs.
(ii) Give **two** distinguishing characteristics of the Kingdom named in **(a)(i)** above.
- (b) State the function of the part labelled **R**
13. (a) What is meant by the term taxonomy?
(b) The scientific name of a rat is *Rattus norvegicus*
(i) Write the name correctly
(ii) Identify the genus and species names
14. List **three** features that distinguish arthropods from other organisms

2. The cell – structure & functions of organelles

1. Name the organelles that perform each of the following functions:
a) Digestion and destruction of worn out organelles.
b) Osmoregulation
2. Explain why the following processes are important during the preparation of temporary slides :-
(a) Staining
(b) Use of a sharp cutting blade
3. In a class experiment to establish the size of an onion cell, a learner observed the following on the microscope field of view.

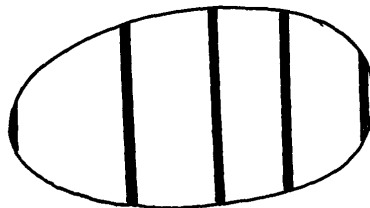

- If the student counted 20 cells across the diameter of this field of view, calculate the size of one cell in micrometers.
4. State the functions of the following cell organelles: (a) Nucleolus.
(b) Plasma membrane
5. What is the of nucleus of a cell made up of?
6. (a) In a laboratory exercise a student observing a drop of pond water under a microscope saw and drew a spirogyra. If the magnification of the eye-piece was x5 and that of the objective lens was x100, what was the magnification of the spirogyra?
(b) If the spirogyra has a length of 5cm at the above magnification, calculate the actual length in micrometers
7. (a) Identify the organelle shown below:-

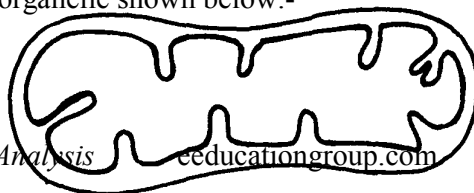

- (b) How is the organelle you have identified in (a) above suited to its function
8. Identify the structures of the cells that perform the following functions:-
- (a) Synthesize ribosomes
- (c) Regulate exchange of substances in and out of the nucleus
9. (a) State the roles of enzyme catalase in living cells
- (b) Which factor inactivates enzyme?
10. The figure below represents a certain cell organelle:-

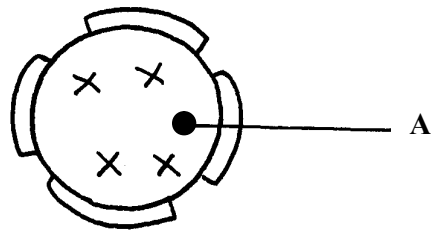

- (a) (i) Identify the cell organelle
- (ii) What is the function of the part labelled A
- (b) Name the organelles that perform each of the following functions;
- (i) Osmoregulation in amoeba
- (ii) Carries out digestion and destruction of worn out cell organelles
11. State **three** properties of the cell membrane
12. The diagram below represents a plant cell

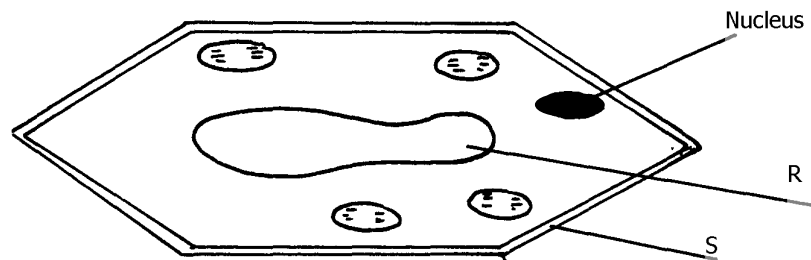

- (a) Name a carbohydrate which forms part of the structure labelled S
- (b) State **two** functions of the part labelled R
- (c) Name **two** structures present in the diagram but absent in the animal cell
13. What do you understand by the following terms
- a) Anatomy
- b) Biochemistry
14. State the function of the following parts of a cell
- a) Ribosome
- b) Chloroplasts
15. a) What is the formula for calculating linear magnification of a specimen when using a hand lens
16. State the function of the following cell structures:- a) Ribosome ;

17. What is the main structural component of:-
 a) Cell wall
 b) Centrioles ;
 c) Cell membrane
18. State **two** characteristics of the kingdom monera which are prokaryotes

19. The diagram below represents a cell

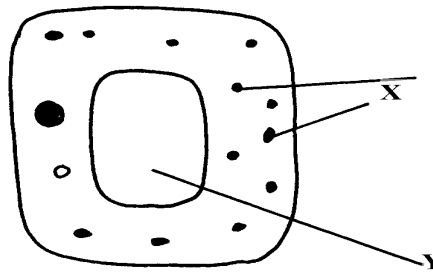

- (a) Name parts labelled **X** and **Y**
 (b) Suggest why the structures labelled **X** would be more on one side than the other
20. During a practical class, four students estimated the field of view to be 3.5mm. Using the low power objective, they observed spirogyra cells across the same field of view and counted 8 cells. Calculate the size of each cell and give your answer in micrometer
21. A student caught an animal which had the following characteristics:-
- Body divided into two parts
 - Simple eyes
 - Eight legs
- a) To what class does the animal belong?
 b) State **two** distinctive characteristics of members of the phylum from which the animal in this question (15) belongs
22. Distinguish between the following terms :-
- a) Magnification and resolution of a microscope
 b) Mounting and staining of a specimen
23. Name the organelle that performs **each** of the following functions in a cell.
- (a) Transport of packaged glycoproteins
 (b) Destruction of worn out cell organelles
 (c) Synthesis of proteins
24. Why are the following procedures done when preparing sections to be observed under a light microscope?
- (a) Making of thin sections
 (b) Using a sharp blade to make the sections
 (c) Staining
25. What are the functions of the following parts of a light microscope?
- (a) Eye piece lens
 (b) Condenser
 (c) Diaphragm
26. Given that the diameter of the field of view of a light microscope is 2000µm. Calculate the

size of a cell in mm if 10 cells occupy the diameter of the field of view

27. State the importance of the following processes in microscopy:
- (a) staining
 - (b) sectioning
28. A cell was found to have the following under a light microscope; cell membrane, irregular in shape, and small vacuoles. Identify the type of the cell above
29. State the functions of the following organelles;
- (a) Lysosomes
 - (b) Golgi apparatus
30. Name the class in phylum arthropoda which has the largest number of individuals
31. State the functions of each of the following parts in a microscope.
- (a) The eye piece lens
 - (b) The objective lens
32. The figure below represents an electron micrograph of an organelle that is found in many cells;

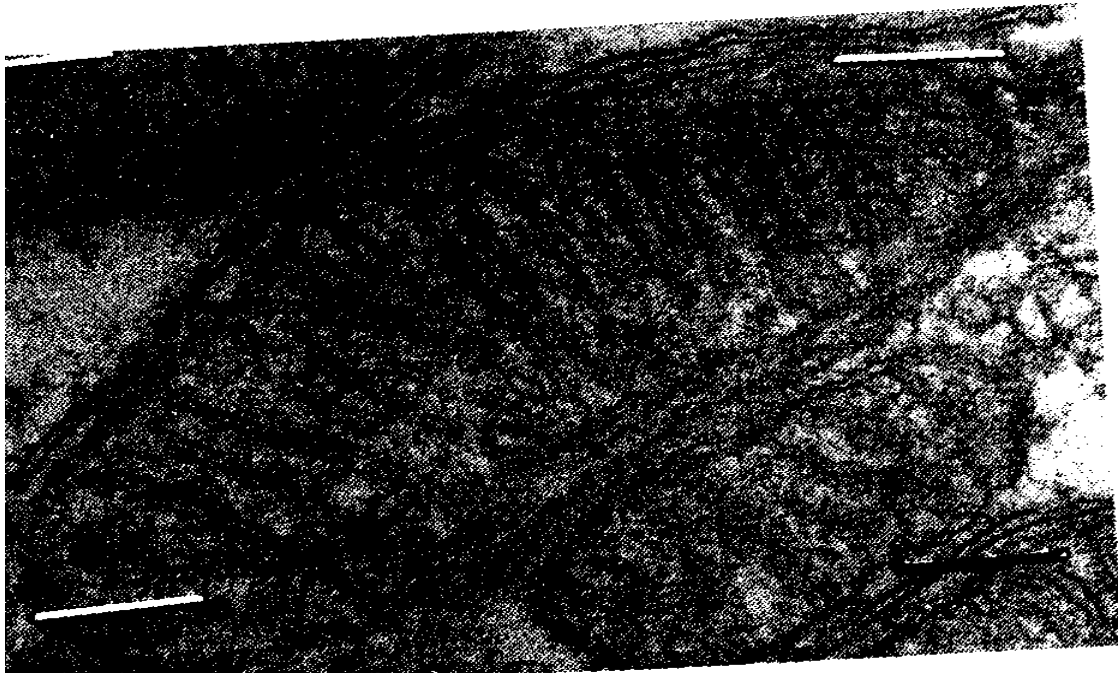

- (a) Identify the organelle
- (b) State the function of the organelle
- (c) What is the importance of infoldings in the inner membrane.
- (d) Give **two** examples of tissues where you would expect many such organelles in animal body.

3. Cell Physiology – Osmosis, Diffusion and Active transport

- Two equal strips **A** and **B** were from a potato whose cell was 30% of sugar. The strip **A** was placed in a solution of 10% sugar concentration while **B** was placed in 50% sugar concentration
 - What change was expected in strip **A** and **B**
 - Account for the change in strip **A**
- An experiment was set-up as shown below and left for one hour

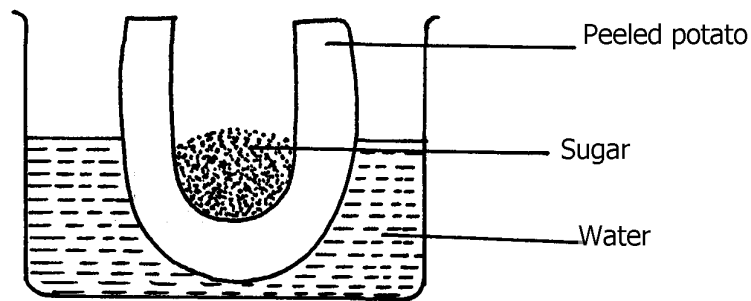

- State the expected result at the end of one hour
 - Explain the observations made in this experiment
- State what would happen in each of the following:-
 - A plant cell placed in: -
 - Strong salt solution
 - Distilled water
 - State **three** physiological processes that are involved in movement of substances across the cell membrane
 - Potato cylinders were weighed and kept in distilled water overnight. They were then reweighed.

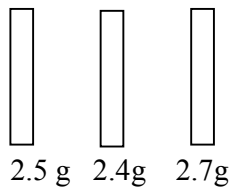

At the beginning of the Experiment.

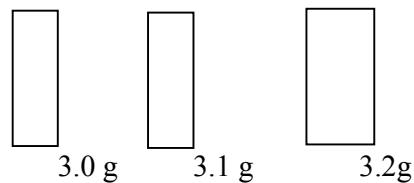

At the end of the experiment

- Calculate the average mass of a potato cylinders after reweighing. Show your working.
 - Explain why mass of the cylinders had increased.
- The diagrams below show a red blood cell that was subjected to a certain treatment.

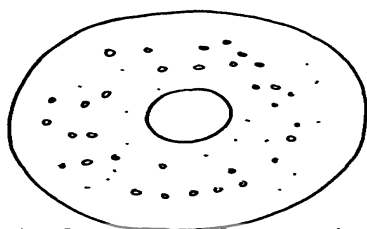

At the start of the experiment

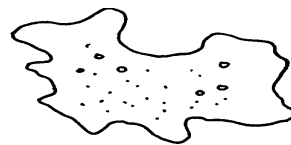

At the end of the experiment

- Account for the shape of the cell at the end of the experiment.
 - Draw a diagram to illustrate how a plant cell would appear if subjected to the same treatment
- The diagram below shows the results obtained when red blood cells are placed in different solution:

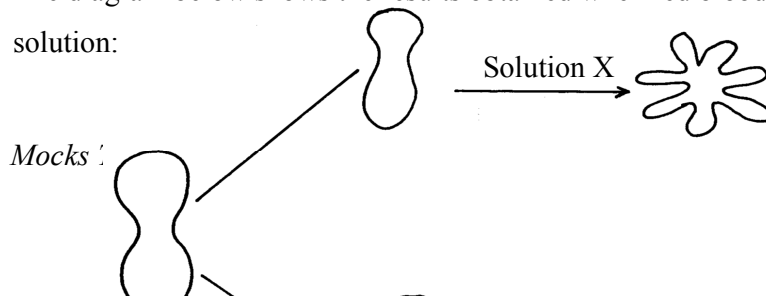

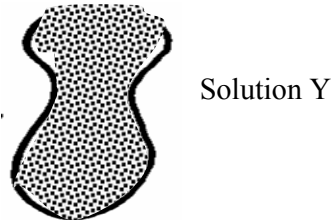

- (a) What name is given to the process that occurs when the cell is placed in solution **Y**?
 (b) Describe the process that would occur in a plant cell when placed in a similar solution as that of solution **X**
8. The figure below shows the results obtained when red blood cells are put in different solutions:-

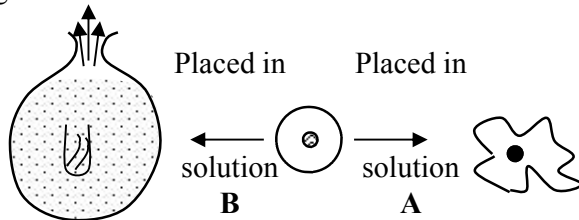

- (a) What is the name given to the process that occurs when the cell is put into solution **B**?
 (b) Compare the results obtained when the cell is put in solution **B** to the results that would be obtained if a plant cell was put in the same solution
9. Briefly state **two** adaptation for each of the following cells to their functions
- Spermatozoon
 - Palisade mesophlly cell
10. The diagram below represents a cell at a certain stage in meiotic cell division

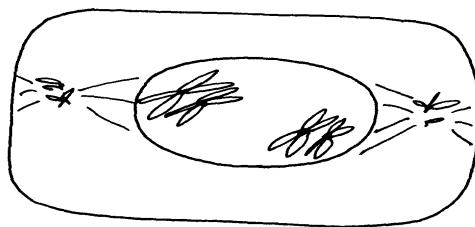

- Name the stage at which the cell drawn above represents
 - Give a distinguishing reason for your answer in **21(a)** above
 - State any **two** differences between mitosis and meiosis
11. What are **two** differences between tropisms and tactic movement
12. An experiment was carried out to investigate the effect of different concentrations of sodium chloride on human red blood cells. Equal amounts of blood were added to equal volumes of the salt solution but of different concentrations. The results are shown in the table below:

Set-up	Number of red blood cells
--------	---------------------------

	Sodium chloride concentration	At start of experiment	At the end of the experiment
A	0.9%	Normal	No change in number
B	0.3%	Normal	Fewer in number

- (a) Account for the results in the set-up
 (b) If the experiment was repeated using 1.4% sodium chloride solution, state the expected results with reference to:
 (i) the number of red blood cells
 (ii) the appearance of red blood cells if viewed under the microscope
13. Name support tissues in plants characterized by the following
 (i) Cells being turgid
 (ii) Cells being thickened by cellulose
 (iii) Cells being thickened by lignin
14. The diagram below illustrates the behaviour of red blood cells when placed into two different solutions X and Y.

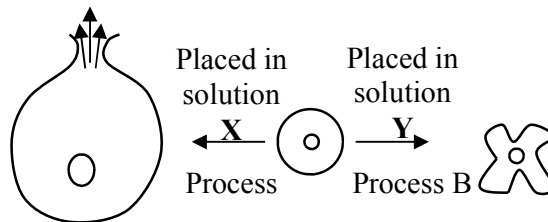

- (a) Suggest the nature of solutions X and Y.
 (b) Name the process A and B.
 (c) What would happen to normal blood cell if it were placed in a solution isotonic.
15. Name **two** plant processes in which diffusion plays an important role
16. Two fresh potato cylinders of equal length were placed one in distilled water and the other in concentrated sucrose solution:
 (a) Account for the change in length of the cylinder in:
 (i) Distilled water
 (ii) Sucrose solution
 (b) (i) What would be the result in terms of length if a boiled potato was used?
 (ii) Explain your answer in (b)(i) Above
 (c) State **two** uses of the physiological process being demonstrated in the experiment
17. The two cells shown below are obtained from two different potato cylinders which were immersed in two different solutions P and Q.

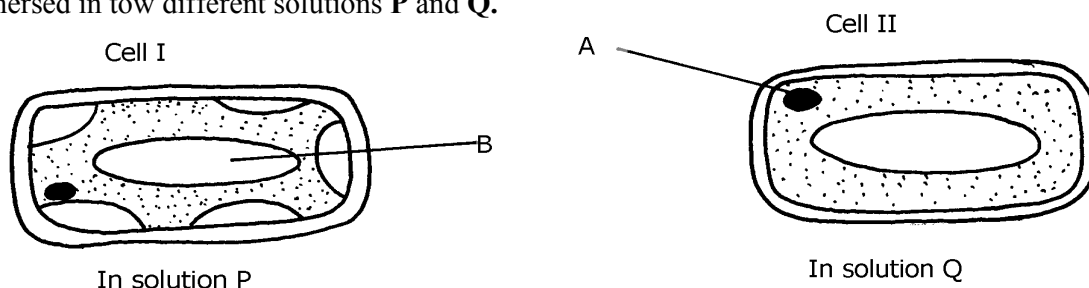

- a) i) Name the structure labelled A.
ii) State the function of structure B.
- b) If eight of cell I were observed across the diameter of the field of view of 0.5 mm.
Work out the actual diameters of each cell in micrometers.
- c) Suggest the identity of the solution Q.
- d) Account for the change in cell I above.
- e) State any **one** importance of the physiological process being demonstrated above in animals.
18. An experiment shown below was set-up to investigate a certain physiological process in plants:-

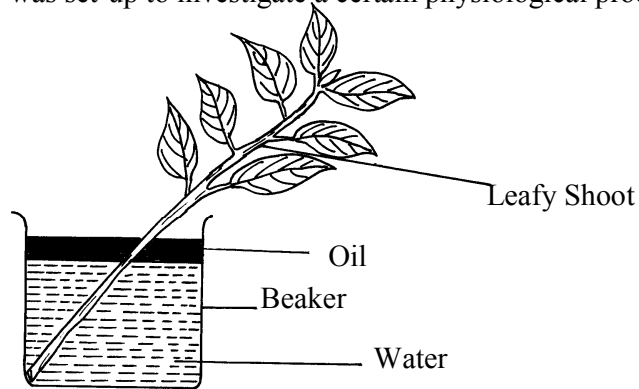

- (a) What process was being investigated?
- (b) Give the role of the oil layer in this experiment
- (c) (i) What observation did the students make after leaving the set-up in bright sunlight for two hours?
(ii) Explain the observation in (c)(i) above
- (d) What effect will the following have on the observation made?:-
(i) Fanning the shoot
(ii) Removing all the leaves from the shoot
(iii) Placing the set-up in the dark
- (e) Suggest a suitable control for this experiment

19. Study the following food web and answer questions that follow:

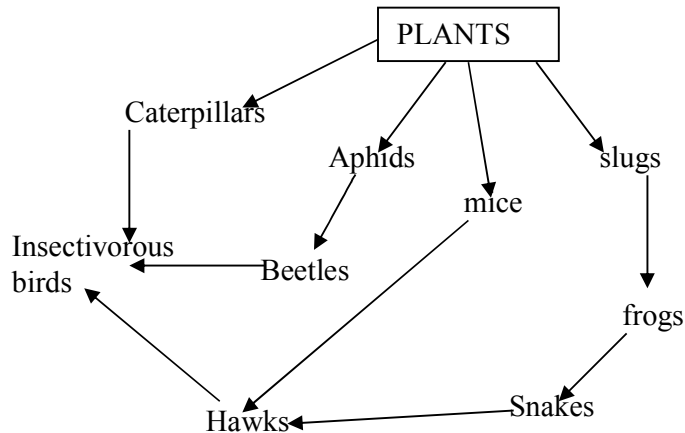

- (a) (i) Name the organisms that occupy the second trophic level
 (ii) What is the other name for the second trophic level
- (b) Write down **two** food chains from the food web that:
 - (i) End with hawks as tertiary consumer
 - (ii) End with hawks as quaternary consumer
- (c) Giving reasons state;
 - (i) the organism with largest biomass
 - (ii) the organism with least biomass

4. Nutrition in (a) plants (b) animals

1. The chemical equation below represents a physiological process that takes place in living organisms:

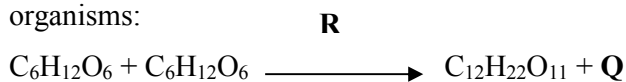

- (a) Name the process **R**
- (b) Name the substance **Q**
2. The diagram below shows cells in plants:-

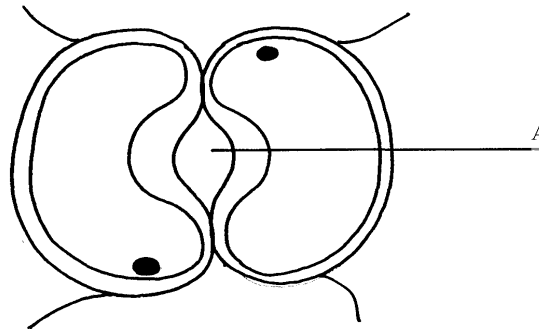

- (a) Identify the cells shown above
- (b) Explain how the cells are adapted to their function
- (c) Explain how accumulation of carbon (IV) Oxide in the cells above would lead to the closure of structure **A**
3. (a) A leaf of a potted plant kept in darkness for 48hours was smeared with Vaseline jelly then exposed to sunlight for 8hours. Explain why the test for starch in the leaf was negative
- (b) Name **two** other processes that were interfered with in the plant

4. List **two** functional differences between plants and animals.
5. Explain how the guard cells are adapted to perform their function.

6. The diagram below shows chemical reactions **A** and **B** which are controlled by enzymes **x** and **y** respectively.

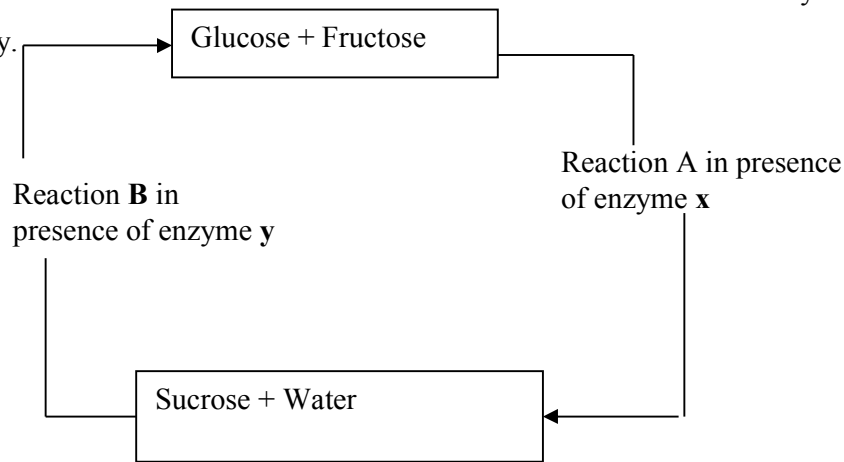

- (a) Name: (i) Reaction **A**.
(ii) Enzyme **y**
7. What are the **two** functions of bile salts during the process of digestion?
8. State **three** adaptations of aquatic plants to photosynthesis
9. A biological washing detergent contains enzymes which remove stains like mucus and oils from clothes which are soaked in water with the detergent:-
(a) Name **two** groups of enzymes that are present in detergent
(b) Explain why stains would be removed faster with the detergent in water at 35°C rather than at 15°C
10. Name the diseases caused by deficiency of : (a) Iodine
(b) Vitamin C
11. Name **two** enzymes and **one** metal ion that are needed in the blood clotting process
12. The diagram below shows how food boles move along the human oesophogus and the Intestine

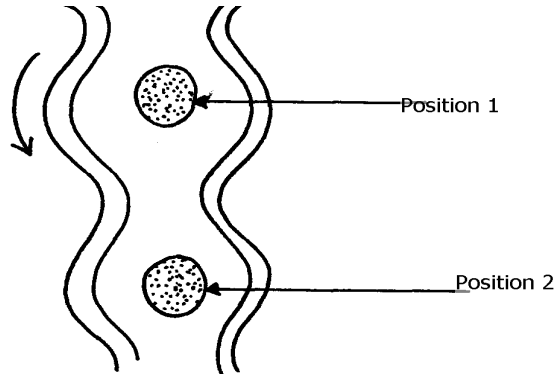

- (a) Identify the process illustrated in the diagram
- (b) Briefly **state** how the movement of food boles from position 1 to position 2 is achieved
- (c) Name **one** component of a persons diet that assists in the movement of food described in (b) above
13. State **two** adaptations of herbivores which enable them to digest cellulose
14. State **two** factors that affect the rate of osmosis

15. A certain organ **K** was surgically removed from a rat, later drastic increase in glucose level in the blood was reported but when substance **Q** was injected into the animal the whole process was reversed.

Identify:
 (i) Organ **K**
 (ii) Substance **Q**

16. a) Name the component of a persons diet that is essential for peristalsis
 b) Give **two** groups of food which are reabsorbed along the mammalian digestive system without undergoing digestion

17. State **three** roles of light in photosynthesis

18. State **two** ways in which the guard cells differ their adjacent epidermal cells

19. One of the components of bile is a chemical left over from destruction of red blood cells

i) Identify the chemical substance
 ii) What is the role of bile in digestion

20. (a) What is peristalsis?
 (b) Explain how the process above is brought about.

21. The following reaction may occur in a forward and backward direction.

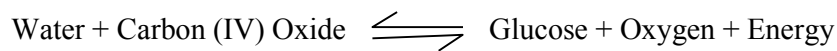

(a) Name the organelle where the reaction occurs in:

(i) Forward direction
 (ii) Backward direction

(b) Give **one difference** and **one similarity** for the two organelles named in (a) above

22. A solution of sugar cane was boiled with hydrochloric acid and sodium hydrogen carbonate was added to the solution, which was then boiled with benedicts solution. An orange precipitate was formed.

(a) Why was the solution boiled with hydrochloric acid and then sodium hydrogen carbonate added in it

(b) To which class of carbohydrates does sugar cane belong?

(c) State the form in which carbohydrates are:

(i) Transported in animals
 (ii) Transported in plants

23. The diagram below is of a certain type of neurons

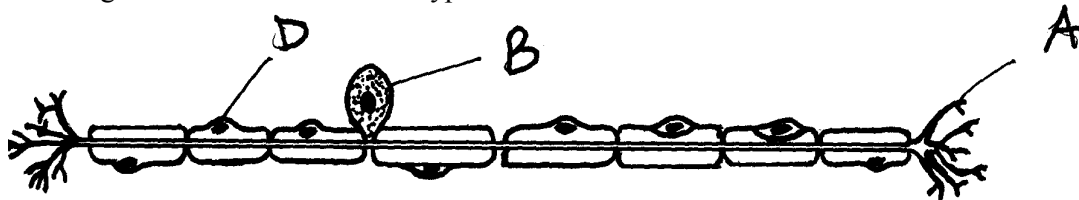

(a) Identify the type of neuron
 (b) Give a reason for your answer in (a) above
 (c) Give the functions of the parts labeled **A**, **B**, and **D**

24. a) The mitochondria organelle has cristae structure on the inner membrane. State the function of

b) The diagram below represents a cell organelle

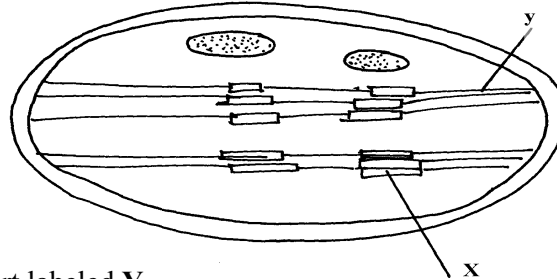

i) Name the part labeled **Y**

ii) State the function of the part labeled **X**

25. a) State the role of emulsification in the digestion of fats in the alimentary canal
b) What is the function of hydrochloric acid in the alimentary canal
26. Briefly explain the effect of poisoning the roots hair on the uptake of nitrate by plants
27. Briefly explain the symbiotic relationship in the root nodule of a leguminous plant
28. Explain how saliva is important in digestion
29. What is the fate of excess glucose in plants?
30. State **two** ways in which guard cells differ from other epidermal cells
31. Briefly explain the fate of the following products from the light stage of the process of Photosynthesis:
 - (a) Oxygen
 - (b) Hydrogen
 - (c) ATP

32. In an experiment to investigate on aspect of digestion, two test tubes A and B were set-up as shown in the diagram below;

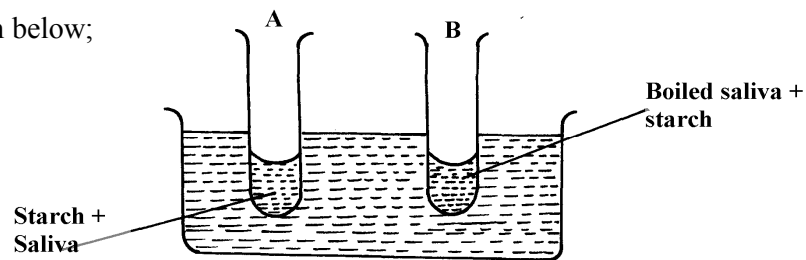

The test tubes were left in the bath for 30 minutes. The content of each test tube was then tested for starch using iodine solution:-

- (a) What was the aim of the experiment?
 - (b) What results were expected in test-tube **A** and **B**
 - (c) Account of the results you have given in **(b)** above in test tube **A** and **B**
33. Below is a process that takes place along the mammalian digestive system:

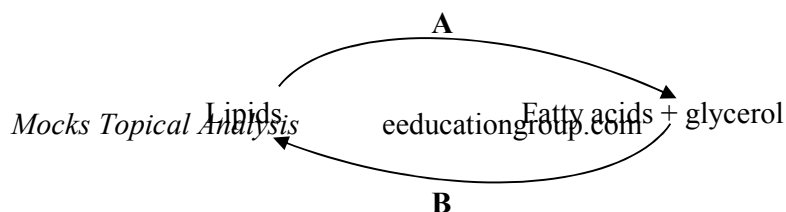

- (a) Name the processes represented by **A** and **B**
- (b) Name part of the alimentary canal where the process **B** takes place

34. The diagram below represents a cell organelle

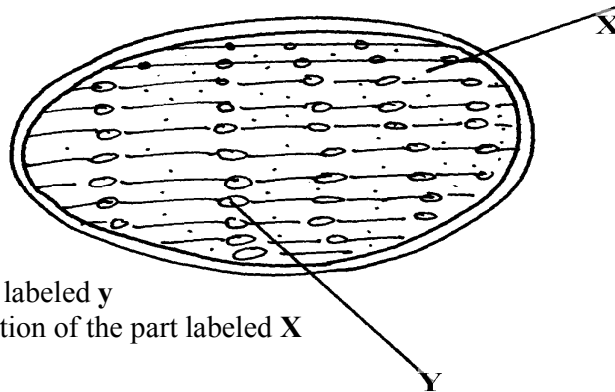

- (i) Name the part labeled **y**
 - (ii) State the function of the part labeled **X**
- (ii) State the function of the vitamin named in (i) above
- 36. (a) Name the disease caused by **schistosoma** parasites in man.
 - (b) How is **schistosome** adapted to its parasitic mode of life?

37. The table below shows **three** enzymes **A, B** and **C** and their respective optimum pH.

Enzyme	Optimum pH
A	6.8
B	2.0
C	8.0

- (a) (i) Name the most likely region of the alimentary canal of a mammal where enzyme **B** would be found.
 - (ii) Give a reason for your answer in (a) (i) above
38. In an experiment to investigate an aspect of digestion, two tubes A and B were set up as shown in the diagram below.

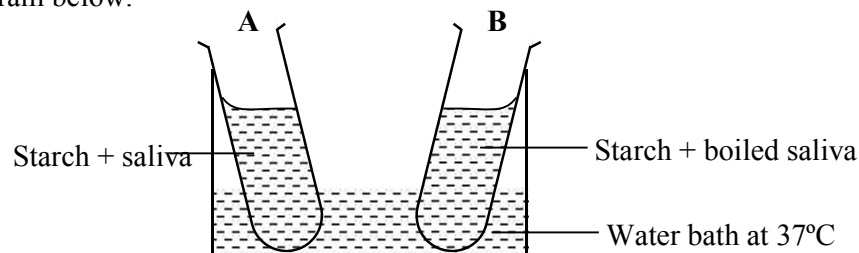

The test tubes were left in the water bath for 30 minutes. The content of each tube was then tested for starch using iodine solution.

- (a) What was the aim of the experiment?
 - (b) Explain the expected in the tube.
39. (a) Name the specific part of the chloroplast where the following processes occur.

- (i) Carbon IV oxide fixation
 - (ii) Photolysis
- (b) State **one** way in which the dark reactions of photosynthesis depends on light reaction.
40. The concentration of carbon IV oxide in a tropical forest was measured during the course of 24 hour period from mid-night. The graph below shows the results obtained.

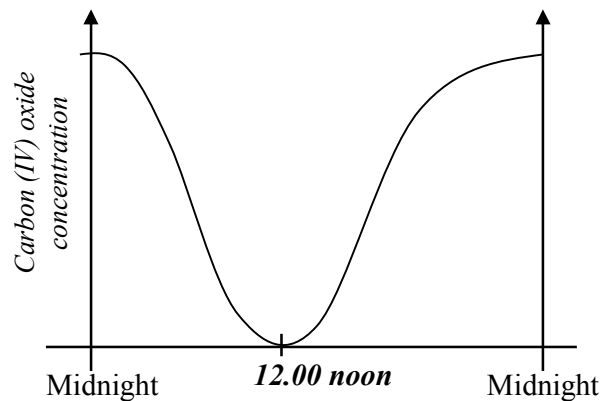

- Account for the results obtained at: (i) Midnight.
(ii) At 12.00 noon.
41. State **three** ways by which the rate of enzyme controlled reactions can be increased.
42. Study the dental formula given below:
- $$\begin{matrix} \mathbf{I} & \mathbf{0} & \mathbf{C} & \mathbf{0} & \mathbf{PM} & \mathbf{3} & \mathbf{M} & \mathbf{2} \\ \mathbf{4} & & \mathbf{0} & & \mathbf{3} & & \mathbf{3} & \end{matrix}$$
- (a) Identify with reasons the mode of feeding of the animals whose dental formula is given above
- (b) Calculate the total number of teeth in the mouth of the above animal
43. Explain why small mammals such as moles feed more frequently than larger ones such as elephants
44. State **three** ways by which plants compensate for lack of the ability to move from one place to another
45. Study the diagram below and answer the questions that follow

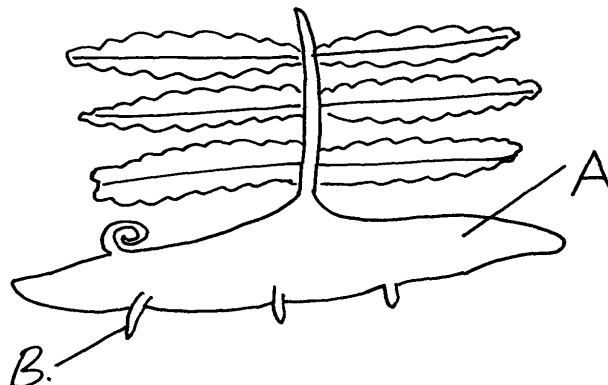

- (a) Label the parts **A** and **B**
 (b) State **one** observable difference between the structure above and the liverwort
46. What is glycolysis?
47. (a) State **two** difference between monosaccharide and polysaccharides
 (b) Name the bond found in proteins
48. Name **two** products of light reaction used in the dark reaction
49. State **two** functions of the large intestine in humans.
50. The diagram below shows a leaf of a growing plant partly covered with aluminium foil. The plant was placed in the sun from morning to midday and then tested for starch.

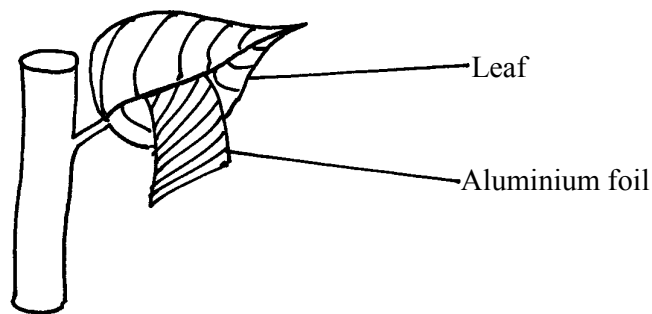

- (a) What was the aim of the experiment?
 (b) State the observation made when the leaf was tested for starch
51. The figure shows the effect of temperature on an enzyme catalyzed reaction.

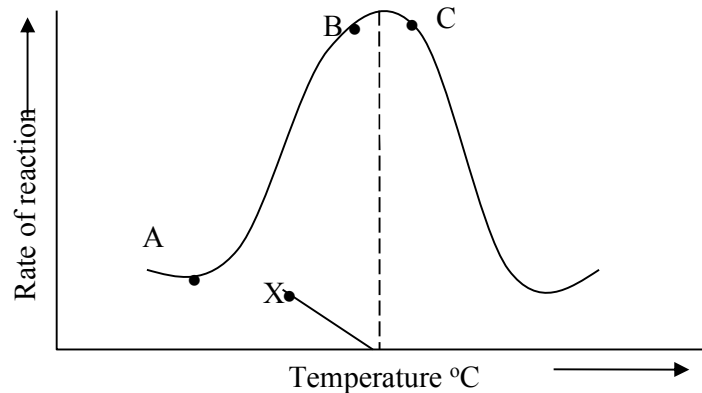

- (a) Explain what happens between **A** and **B**
 (b) What is **X**?
52. Name **two** mineral elements that are necessary in the synthesis of chlorophyll.
53. The figure below is a diagram of the anterior portion of the tapeworm. **Taenia solium**.

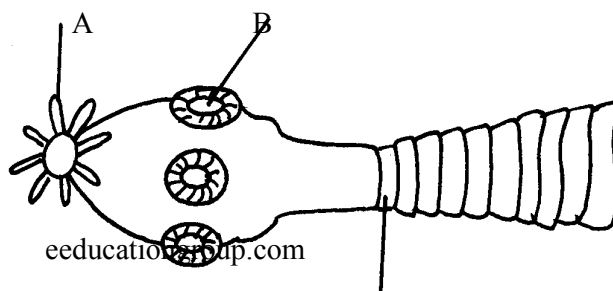

- (a) Name the parts labeled **A**, **B**, and **C**
 (b) What is the intermediate host of *Taenia Solium*?
54. The diagram below represents a longitudinal section through the ileum wall

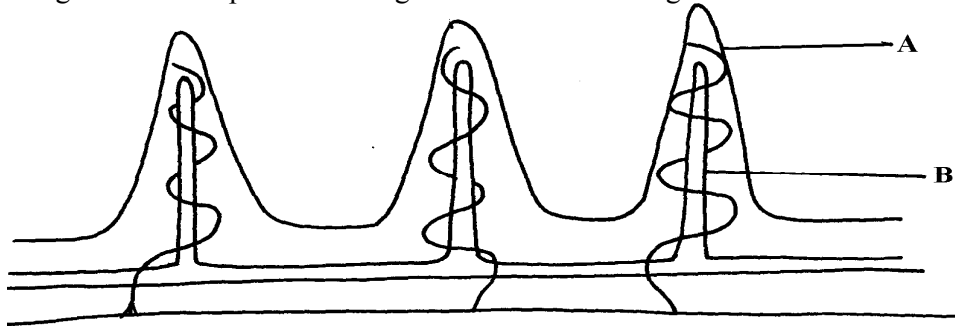

- a) Identify the structure labeled **A** and **B**
 b) State **one** function of **A** and **B**
 c) State **two** functions of the ileum
 d) Explain the role of the liver in digestion
 e) State the endocrine role of the pancreas in a mammal
55. The chart below shows the relationship between concentration of CO_2 around the plant and the rate of photosynthesis

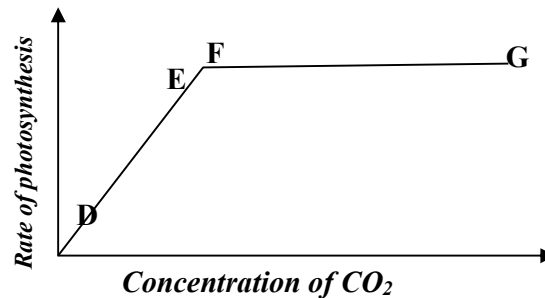

- (a) Account for the rate of photosynthesis between **D-E**
 (b) Account for the rate of photosynthesis between **F-G**
 (c) Briefly describe the reactions during the light stage of photosynthesis
56. The diagram below shows the effect of varying light intensity on the exchange of carbon IV oxide between the leaves of a green plant and the atmosphere.

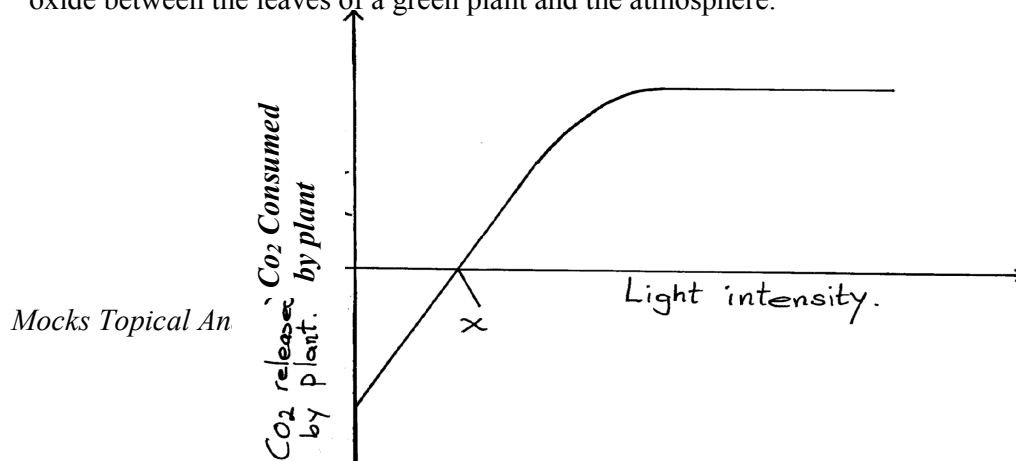

Light Intensity

*CO₂ released
by plant*

- a) What is the name given to the point marked x?
 - b) i) With reference to carbon IV oxide exchange state what happens at point x.
ii) Explain how the effect observed at point x occurs.
 - c) Explain why there is a net uptake of carbon IV oxide at light intensity above x.
 - d) What would happen to the plant if light intensity falling on it were maintained at x throughout?
 - e) What can you say about the exchange of oxygen between the plant and the surrounding air at intensities below x?
57. The following diagram of a leaf shows what happens in a plant leaf during photosynthesis:-

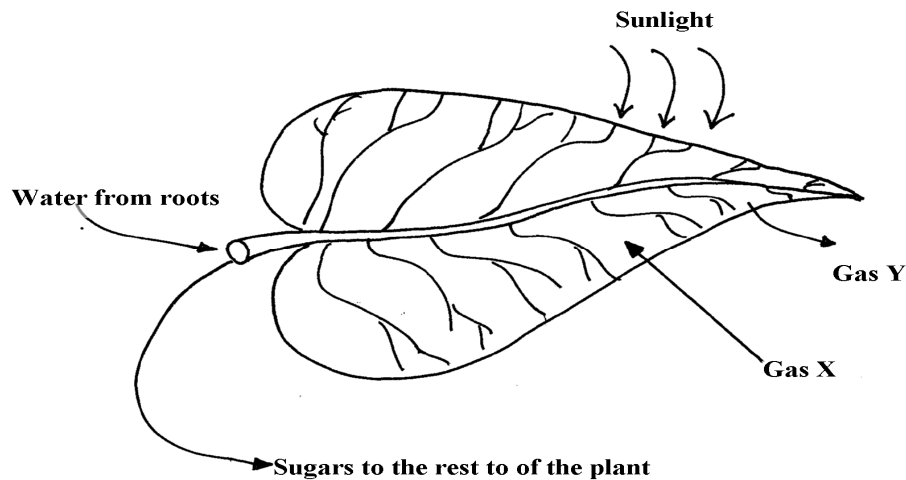

- (a) Give **two** ways in which leaves are adapted to absorb light
 - (b) Name the gases labelled **X** and **Y**
 - (c) Name the tissue that transports water into the leaf and sugars out of the leaf
 - (d) Explain why it's an advantage for the plant to store carbohydrates as starch rather than as sugars
58. (a) What is meant by digestion?
(b) Describe how mammalian small intestine is adapted to its function
59. Form one students from Inungo school arranged their apparatus as shown below, to investigate a certain phenomenon. The set up was placed in light.

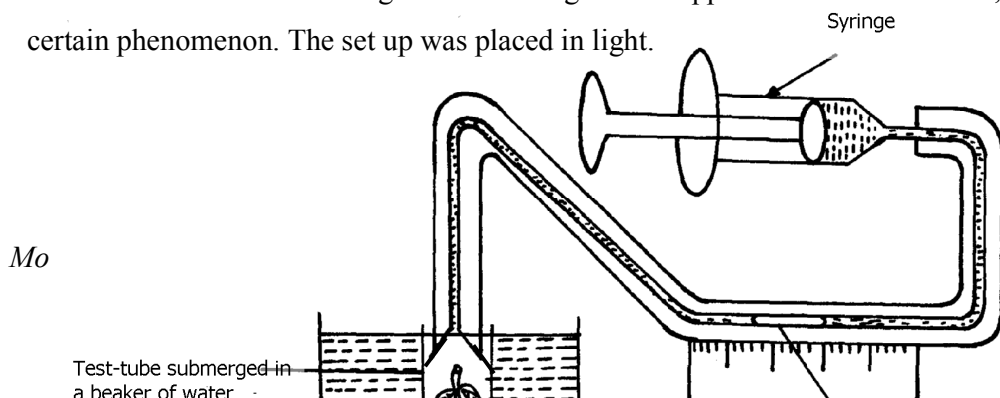

Mo

- (a) State the likely aim of the set up
 - (b) State the role of the syringe in the set-up above
 - (c) (i) Name gas **X**
 - (ii) Write an equation to show how gas **X** was formed in the set-up
 - (d) State **three** factors that increase the rate of enzyme activity
 - (e) Give a reason why the test tube is immersed in a beaker of water
60. A student was culturing *E. coli* (a bacterium) in a Petri-dish. He placed the Petri-dish in an incubator at 30°C. He removed it from the incubator the following day and found that five colonies of bacteria had grown. He decided to return it into the incubator to give it more time. When he removed it fourteen days later, he could not observe any colony.
- a) Why was there no colony on the fourteenth day?
 - b) Explain how bacteria cause spoilage of stored food in warm moist conditions.
 - c) Name other organisms which also cause food spoilage.
 - d) State their economic importance to nature.
61. The table below shows the results of an experiment carried out to determine the rate of photosynthesis at different light intensities and varying Carbon (IV) oxide concentrations. The rate was determined by counting the number of bubbles per minute. The temperature was kept constant

Light intensity in lux	% carbon(IV)oxide concentration						
	0.0%	0.3%	0.6%	0.9%	1.2%	1.5%	1.8%
1500	0	16	30	38	40	40	40
6000	0	52	80	96	100	98	100
10000	0	80	100	115	120	122	120

- a) On a graph paper provided, draw a graph for each of the light intensities. All the three graphs should be plotted on the same axis (rate of photosynthesis on vertical axis and carbon (IV) oxide concentration on horizontal axis)
- b) What is the effect of an increase in carbon (IV) oxide concentrations and light intensities
- c) Briefly explain how aquatic green plants meet light intensities and carbon (IV) oxide requirement
- d) Using the data provided in the table state **two** factors required by the green plants for food production

62. Explain how the mammalian intestines are adapted to perform their function.
63. A healthy plant was kept in the dark for 24 hours following which two of its leaves were enclosed in glass flasks as shown below. The set up was the exposed to sunlight for a number of hours.

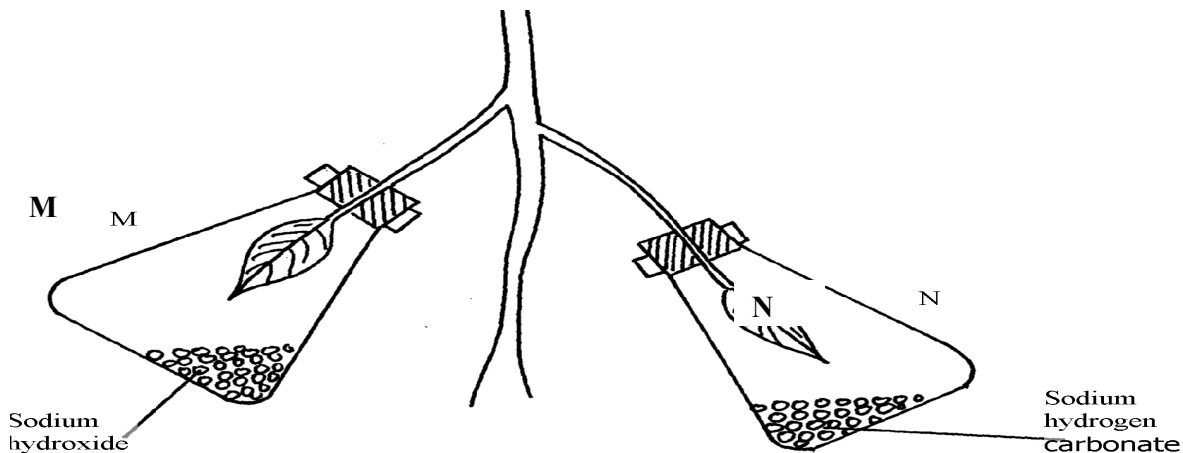

- (a) Why was it necessary to keep the plant in the dark for 24 hours?
- (b) Give the function of each of the following in the experiment
- Sodium hydroxide
 - Sodium hydrogen carbonate
- (c) Explain the expected results in leaf.
- M when tested for starch
 - N when tested for starch?
- (d) Suggest a suitable control for this experiment
64. The diagram below shows an experiment that was carried out to measure how fast a were plant such as Elodea photosynthesizes

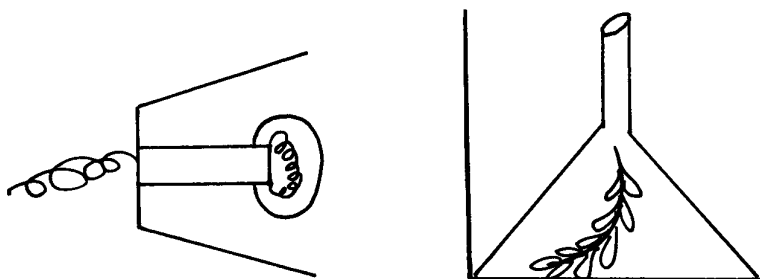

The shoot was exposed to different light intensities and the rate of photosynthesis estimated by counting the number of bubbles of gas leaving the shoot in a given time. the results are given below;

Number of bubbles per minute	7	14	20	24	26	27	27	27
Light intensity (Arbitrary units)	1	2	3	4	5	6	7	8

- a) Plot these data on a piece of graph paper provided
- b) At what light intensity did the shoot produce ;
- 18 bubbles per minute

- ii) 25 bubbles per minute
 - c) Give **two** better ways of measuring the rate of photosynthesis than counting bubbles
 - d) What is the role of light intensity in photosynthesis
 - e) Account for the expected results of doing this experience at the following temperature;
 - i) 4°C
 - ii) 34°C
 - iii) 60°C
 - f) Other than light intensity and temperature, name other factors that affect the rate of photosynthesis
65. In an experiment, a leaf from a plant which had been kept in the dark overnight was boiled in water for a minute. It was then boiled in alcohol and washed in warm water. Iodine solution was then added onto the leaf:
- (a) Why was the leaf boiled in;-
 - (i) Water
 - (ii) alcohol
 - (b) (i) What observation was made on the leaf after adding iodine solution
 - (ii) Give a reason for your answer in (b) above
 - (c) What was the aim of the experiment
 - (d) Why was it necessary to wash the leaf in warm water
 - (e) What is a variegated leaf?
 - (f) Write a word equation for the process of photosynthesis

5. Transport in (a) plants (b) animals

1. Explain why a fresh wound on the skin bleeds more on a hot sunny day than on a cold chilly day
2. State **three** adaptations of red blood cells to their functions.
3. How are sieve tube elements adapted to their function
4. Name the **polysaccharides** found in the following structures:-
 - (a) **Exoskeleton**
 - (b) **Xylem vessels**
5. State **three** factors that maintain transpiration stream
6. (a) List **three** forces that facilitate the transport of water and mineral salts up the stem.
- (b) Name the tissue that is removed when the bark of a dicotyledonous plant is ringed.
7. Study the dental formula of an organism below..

$$I^{3/3}, C^{1/1}, Pm^{3/2}, M^{1/1} = x$$

- (a) (i) What is the total number of teeth this organism possess?
 - (ii) What is the mode of feeding of the organism?
 - (b) State **two** functions of mucus produced along the alimentary canal.
8. The diagram below shows a bone obtained from a mammal.

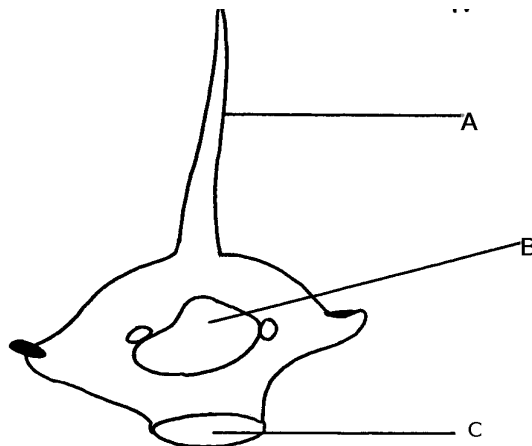

- (a) Name the part of the skeleton from which the bone has been taken.
 (b) Label the parts **B** and **C**.
 (c) State the functions of part **A**.
9. What is the destination of materials translocated in plants.
10. A person whose blood group is **AB** requires a blood transfusion, name the blood groups of the donors.
11. Explain why capillaries are: (i) Thin walled
 (ii) Branched
12. An experiment was set-up as shown below to investigate a certain plant process:

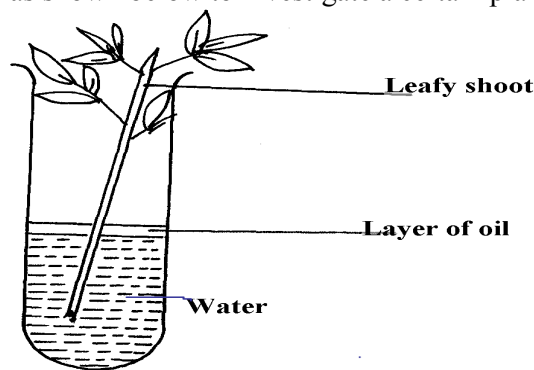

- (a) What process was being investigated above?
 (b) What observation was made if;
 (i) The experiment was left in strong wind for one hour?
 (ii) All the leaves were removed from the plant?
13. How is aerenchyma tissue adapted to its function
14. (a) State **three** structural differences between arteries and veins in mammals
 (b) Name a disease that causes thickening and hardening of arteries
15. Identify **two** forces that help in upward movement of water in plants
16. State **three** ways in which red blood cells are adapted to their functions
17. (a) Distinguish between tissue fluid and lymph
 (b) Explain why deficiency of vitamin **K** leads to excessive bleeding even from small cuts
18. Name the type of circulatory system found in the phylum Arthropoda
19. Name the blood vessel that nourishes the heart
20. a) In which form is oxygen transported in the blood.
 b) Why do plants not take in oxygen during the day although they need it for respiration
21. Name a disease of the blood characterized by excessive production of white blood cells
22. Laboratory analysis of a patient's urine revealed the following concentration of various substances:

Blood proteins	0.00%
----------------	-------

Water	50%
Glucose	48%
Salts	0.8%
Urea	1.2%

- a) From the analysis above, which disease is the patient suffering from
 b) Name **two** symptoms of the disease in **3(a)** above
23. The diagrams below show two conducting elements of the xylem tissue

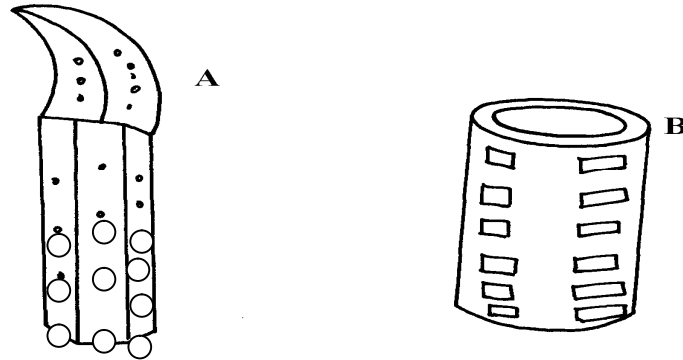

- a) Identify each of them A and B
 b) What makes the cellulose side walls of both A and B able to prevent collapsing?
24. Explain why the rate of transpiration is reduced when humidity is high
25. (a) State **two** functions of the xylem vessels,
 (b) List **two** structural adaptations that make xylem vessels suitable to their function
26. (a) What is peristalsis?
 (b) Explain how the process above is brought about.
27. The diagram below shows a part of a circulatory system. The arrows indicate the direction of the flow of blood;

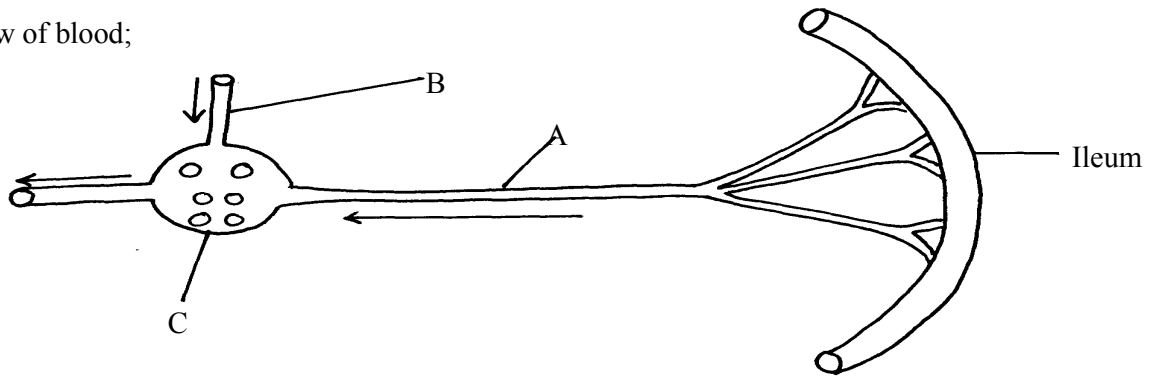

- (a) Identify the blood vessels labeled **A** and **B**
 (b) Explain why it is important to transport food substances to organ **C** before being released for circulation to the rest of the body
28. Name **four** methods plants employ to remove excretory waste products
29. a) State the form in which oxygen is transported in the mammalian blood
 b) Why is it dangerous to sleep in an enclosed room with a burning jiko
 c) Why do plants not take in oxygen during the day although they need it for respiration
30. Name a disease of blood characterized by excessive – production of white blood cells

31. The table below is a representation of a chromosomal mutation

Before mutation	L	M	N	O	P	Q
After mutation	L	O	N	M	P	Q

- (a) Name the type of chromosomal mutation represented above
 (b) Name **one** mutagenic agent
32. The diagram shows a section through a plant organ.

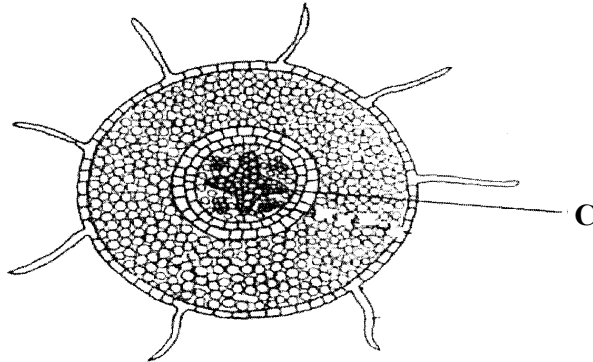

- (a) (i) Name the class of the plant from which the section was obtained belong.
 (ii) Give a reason for your answer in **(a)(i)** above
 (b) How is the part labelled **C** adapted to its functions?
33. State **two** roles of transpiration to a plant
34. Uptake of water by plants is not affected by metabolic poisons. Explain.
35. The diagram below represents a plant tissue.

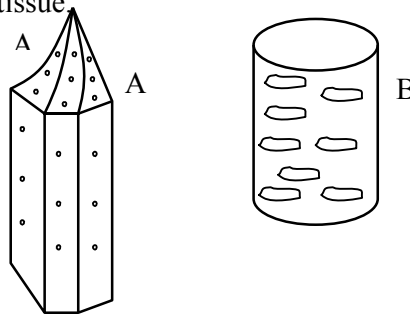

- (a) Identify each of them.
 (b) What property makes **B** to be more efficient in function?
 (c) What makes the walls of both **A** and **B** impermeable to water and solutes?
36. A woman gave birth to a child of blood group B⁺ (B positive). Name the two antigens that determined her child's blood group.
37. A transfusion of RH⁺ blood was given to a patient with Rh⁻ blood. After one week a similar transfusion was given to the same patient. What was likely to be the effect of the second transfusion?
38. The diagrams below show stages in the process of feeding shown by amoeba.

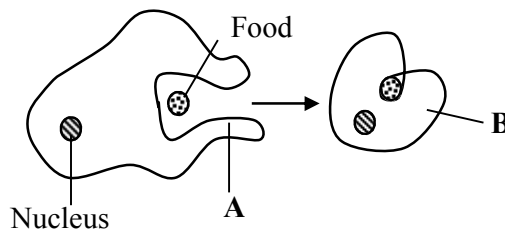

- (a) Name the part labeled **A**.

- (b) Name the process illustrated in the diagram above.
 (d) Name the type of cell in human beings that exhibit this process.
39. (a) Why are xylem vessels more efficient in the transport of water than tracheids?
 (b) What is the significance of xylem vessels being dead?
40. Distinguish between guttation and transpiration
41. Other than transport, state one other function of xylem tissue in plants
42. State **two** functions of aerenchyma tissue in plants
43. (a) What is sickle-cell anaemia?
 (b) Identify the part of the heart that initiates the heart beat
44. (a) Give a reason why the left ventricle muscles are thicker than the right ventricles muscles
 (b) State the forms in which carbon (IV) oxide is transported in the blood
45. Explain how the following adaptation reduce transpiration in xerophytes
 (a) Sunken stomata
 (b) Thick waxy cuticle
46. Name the: (a) Material that strengthens xylem tissue
 (b) Tissue that is removed when the bark of a dicotyledonous plant is ringed
47. The diagram below shows the traverse section of a young stem.

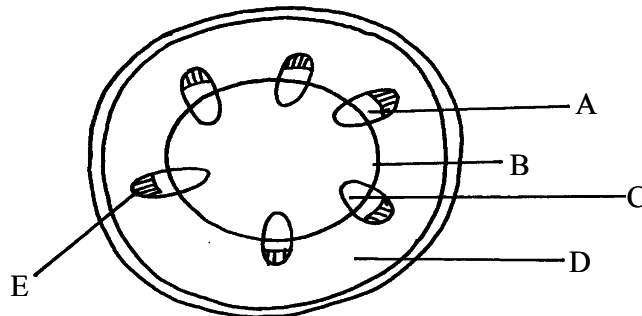

- (a) What are the functions of the structures labeled **A**, **B** and **C**
 (b) What type of cells are found in the parts labeled **D**
 (c) Name the tissue labeled **E**
48. Name the components of blood that do not enter the renal tubule in mammals
49. Outline the route taken by a molecule of glucose from the ileum up to the kidney.
50. The flow chart below shows a blood transfusion pathway

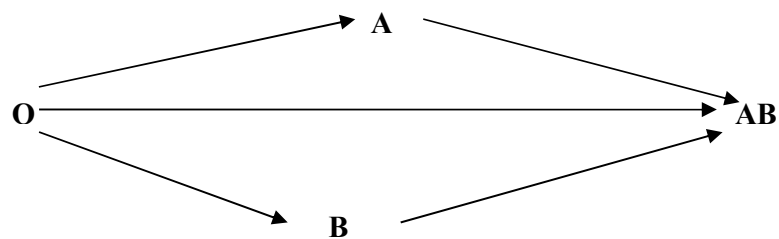

- (a) What **three** conclusions can you draw from the flow chart?
 (b) State **two** precautions that must be observed during blood transfusion
 (c) Explain how blood clot is formed once a blood vessels is injured
51. The figure below represents a diagram of a photometer;

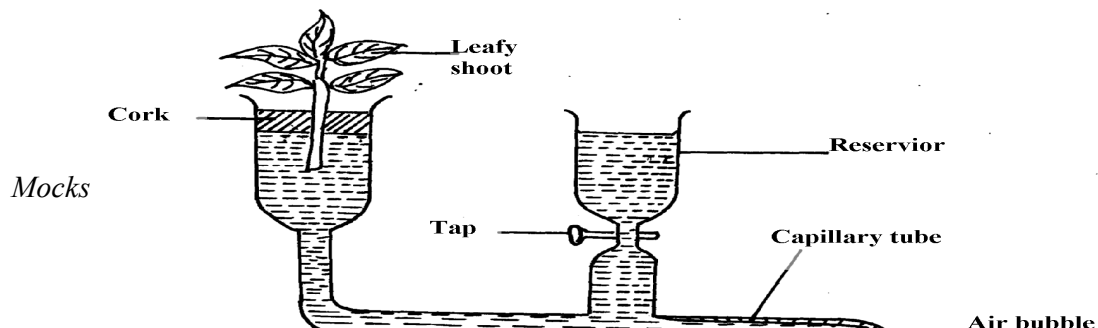

- (a) What is the photometer used for ?
 (b) State the precautions which should be taken when setting up a photometer
 (c) Explain what you will expect if set up was placed under the following environmental conditions;
 (i) Dark room
 (ii) Leafy shoot enclosed in polythene bag
 (iii) In a current of air created by a fan
52. The amount of blood flow through various parts of the body of a mammal was measured in cm^3 per minute at rest and during different physical activities. Results are shown below.

	Blood flow in cm^3/min		
	At rest	During light Exercise	During strenuous Exercise
Heart muscles	200	300	1050
Gut	1300	1000	400
Skeletal muscles	1100	5050	23000
Kidneys	900	650	250
Skin	400	1300	600

- a) Calculate the percentage change in blood flow through the skeletal muscles and gut when the mammal was exposed to strenuous exercise.
 i) Skeletal muscles
 ii) Gut
- b) Account for the differences in amount of blood flow through the gut and skeletal muscles;
 i) At rest
 ii) During strenuous exercise
- c) Account for the result obtained for the skin during light exercise
 d) Name **two** substances which are removed from the body by the kidney
53. The diagram below represents a transverse section of a young stem.

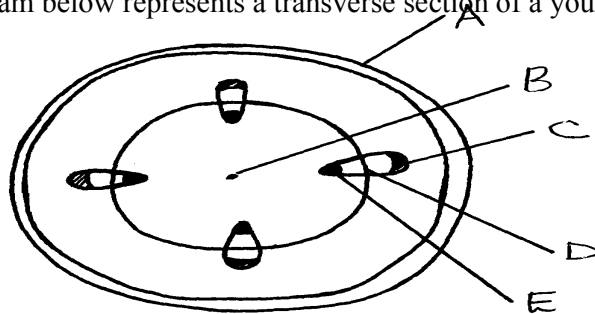

- (a) Name the parts labeled **A**, **B** and **D**
 (b) State the functions of the parts labeled **C** and **E**
 (c) List **three** differences between the section above and the one that would be obtained from the root of the same plant

54. Describe the functions of the various components of the mammalian blood

6. Gaseous exchange in (a) plants (b) animals

1. a) Name the site of gaseous exchange during breathing in mammals.
b) State **three** characteristics of the site named in (a) above.
2. Why would carboxyhaemoglobin lead to death?
3. State **two** causes of coronary thrombosis
4. What adaptation do red blood cells have for transportation of carbon (IV) oxide?
5. (a) What is Respiration Quotient (RQ)?
(b) (i) Calculate the RQ of the food substance shown by the equation below.

$$2C_{51}H_{98}O_6 + 145 O_2 \longrightarrow 102CO_2 + 98H_2O + \text{Energy}$$
(ii) Name the food substance being oxidized in b (i) above.
6. Outline **three** ways in which the gills of Tilapia fish are modified to perform their function.
7. Identify the surfaces of gaseous exchange in the following:-
(i) Paramecium;
(ii) Roots;
(iii) Frog;
8. (a) Name **two** gaseous exchange
(b) Explain how oxygen gets into the haemolymph of an insect
10. (a) Outline **two** physiological changes that occur in the body to lower the level of Carbon (IV) Oxide after vigorous physical exercise
(b) Name the site of respiration in a cell
11. What is the importance of counter current flow in the exchange of gases in a fish
12. State **four** ways in which red blood cells (**RBC**) are adapted to their function
13. (a) (i) Where in a cell does glycolysis take place?
(ii) Name the product of the above process
(b) Briefly explain Krebs's cycle in a plant cell during anaerobic respiration
14. Describe the changes that occur to the rib cage and the diaphragm during inspiration
15. a) What is translocation
b) Name **two** forces that maintain transpiration stream
16. Most carbon (IV) oxide is transported from tissues to the lungs within the red blood cells and not in the blood plasma. Give **two** advantages of this mode of transport
17. Give a reason why halophytes have pneumatophores
18. Give **two** characteristics of respiratory surfaces in animals
19. Give a reason for each of the following on mammalian Red blood cells
(a) Absence of the nucleus
(b) Biconcave shape
20. State **two** ways in which bodies of people living in high altitude areas respond to low oxygen concentration.
21. Explain what would happen to a mammalian Red blood cell 30 minutes after being placed in

22. (a) State **two** ways in which the surface area of the fish filaments is increased for efficient gaseous exchange.
(b) What is the importance of counter flow system in the filaments of a fish.
23. The apparatus below illustrates breathing in mammal.

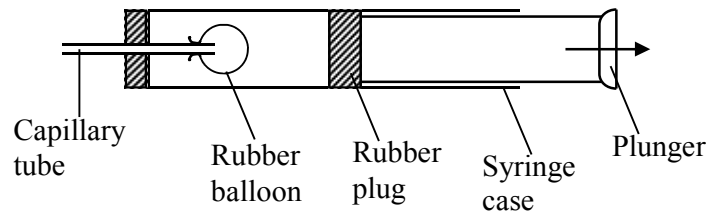

Describe what happens if the rubber plug is pulled in the direction shown by the arrow.

24. Describe the path taken by oxygen gas from atmosphere to the tissues of an insect.
25. Why should respiratory surfaces be: (i) Moist
(ii) Thin
26. The set up below represents an experiment to investigate the process of photosynthesis. The set up placed in sunlight for six hours.

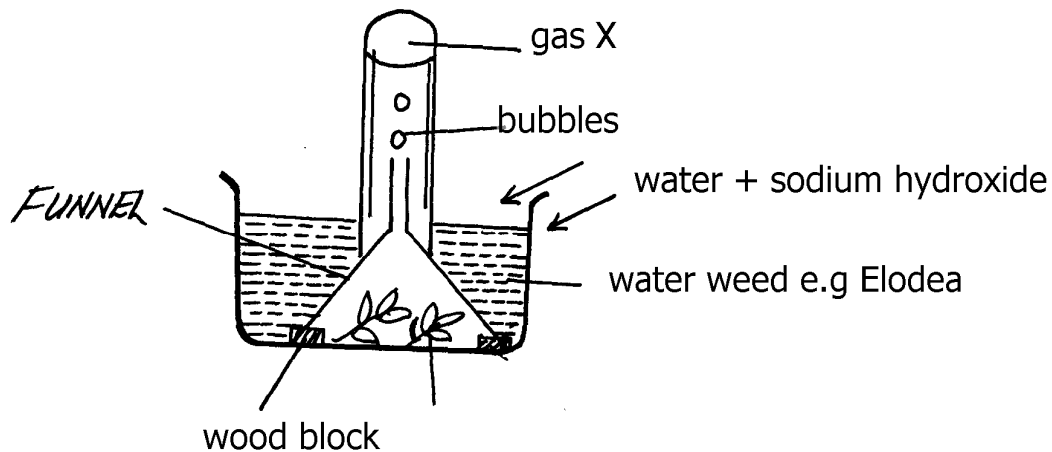

- (a) Why was sodium hydrogen carbonate added to water in this experiment?
(b) Explain why the number of bubbles reduced by evening
(c) Explain why the water was used in this experiment
(d) Explain why the water was used in this experiment
27. (a) State **two** adaptations of red blood cell to its functions
(b) Name **two** ways in which carbon (IV) Oxide is transported in mammalian blood
28. The diagram below represents an organ from a bony fish. Study the diagram and answer the questions that follow:

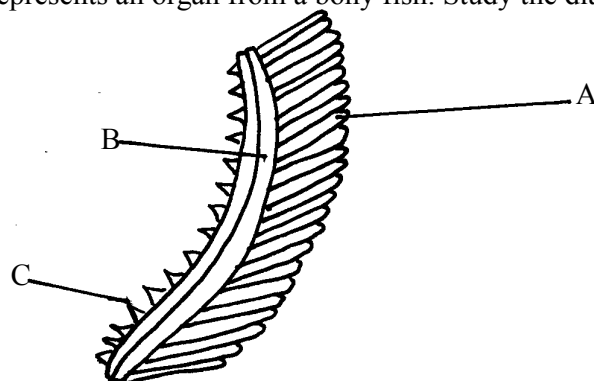

- (a) State the functions of each of the following:
 (b) How is the structure labeled **C** adapted to its function?
29. State how the tracheal system in insects is adapted for gaseous exchange.
30. Differentiate between active immunity and passive immunity
31. Name **three** sites where gaseous exchange takes place in terrestrial plants.
32. An athlete training to take part in an international competition moved to a high altitude area where he was to train for twelve days before the competition. He took his pulses per minute daily and tabulated them as shown below:-
- a) Other than pulse rate, name **one** other process which was affected by change of altitude
 b) Account for the change in pulse rate from:- i) Day 1 to day 7
 ii) Day 8 to day 12
 c) Explain the advantage this athlete has over the one who trains in a lower altitude area
 d) The equation below represents a reaction which takes place during rapid muscular movements in humans.
- Glucose \longrightarrow Lactic acid + 150KJ
- i) State **two** effects of this reaction to an individual
 ii) How is lactic acid finally eliminated from the muscle tissues of the human after the muscle
33. a) State any **two** structures used for gaseous exchange in plants.
 b) Name any **two** sites where gaseous exchange takes place in a leaf of a terrestrial plant.
 c) State any **two** types of leaves and their respective functions.
 d) Briefly describe how stoma opens.
34. The diagram below represents a section of the human respiratory system:

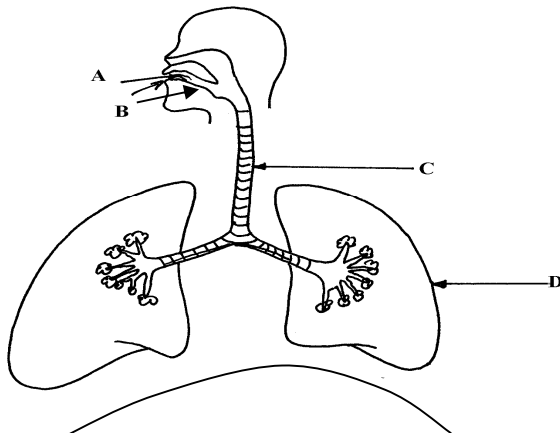

- (a) One can inhale through path **A**, or **B**. Giving reasons, state the more appropriate path.
 (b) How is the part labelled **C** adapted for its function?
 (c) Explain the effect of regular tobacco smoking to the functioning on the organ labelled **D**
35. (a) How is the structure of mammalian gaseous exchange system adapted to its functions
 (b) Describe the mechanism of opening and closing of the stomata using the photosynthetic theory
36. (a) Describe the mechanism of inhalation in man.
 (b) Using photosynthetic theory explain the mechanism of opening of stomata.
37. In an experiment to investigate a certain processes in a given plant species, the rate of carbon (IV) oxide consumed and released were measured over a period of time of the day. The results of the

investigation are shown in the table below:

Time of the day (hours)	6	8	10	12	14	16	18	20	22	24
Carbon (IV) oxide consumed in mm ³ /min	10	43	69	91	91	50	18	0	0	0
Carbon (IV) oxide released in mm ³ /min	38	22	10	3	3	6	31	48	48	48

- b) Name the biochemical processes represented by;
- Carbon (IV) oxide consumption
 - carbon (IV)oxide release
- (c) Account for the shape of the curve for carbon (IV) oxide consumption between;
- 6-16 hours
 - 20-24 hours
- (d) Account for carbon (IV) oxide released between 12-16 hours
- (e) (i) What is compensation point?
 (ii) From the graph state the time of the day when the plant attains compensation point
- (f) Explain how high temperature above optimum affects the rate of carbon (IV) oxide consumption in the plant.

7. Respiration

- Distinguish between gaseous exchange and respiration
 - Name the products of anaerobic respiration in plants
- State **two** phases of aerobic respiration
 - With a reason, state the phase that yields more energy
- A process that occurs implants is represented by the equation below:-

$$C_6H_{16}O_6 \longrightarrow 2C_2H_5OH + 2CO_2 + \text{Energy}$$

(Glucose) (Ethanol) (Carbon (IV) Oxide)

 - Name the process
 - State the economic importance of the process named in (a) above
- Give a reason why it is difficult to calculate respiratory quotient (RQ) in plants
- Explain what is meant by the term oxygen debt in human beings
 - What are the end products of anaerobic respiration in animals
- The apparatus below was set up by a student to find out the changes in gases during

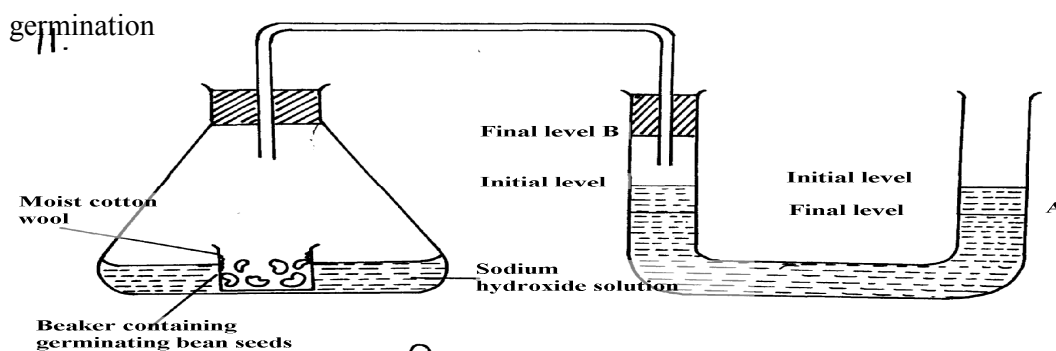

- After 48 hours the level of water in the U-tube at **A** and **B** was as shown. Explain the observation
- Calculate the respiration quotient (**RQ**) from the equation below:-

$$2C_{51}H_{98}O_6 + 145O_2 \longrightarrow 102 CO_2 + 98H_2O + \text{Energy}$$
- Identify the substrate being respired in the above equation

7. One molecule of lipid gives more energy than one molecule of glucose when respired aerobically but it is NOT always used as a respiratory substrate
- Give **two** reasons for this
 - Name **two** disaccharides which are reducing sugar
8. (a) (i) Where in a cell does glycolysis take place?
(ii) Name the product of the above process
(b) Briefly explain Krebs's cycle in a plant cell during anaerobic respiration
9. How is the mammalian skin adapted to its protective function?
10. The oxidation state of a certain food is represented below by a chemical equation:-

$$2 C_3H_2O_2N + 6O_2 \longrightarrow (NH)_2CO_2 + 5CO_2 + 5H_2O$$
 (a) Calculate the respiratory quotients (RQ) of the food substrate
 (b) Identify the food substrate
11. Whooping cough is a disease of the respiratory system name the causative agents and give **two** symptoms
12. How does the sunkness of stomata help in minimizing the rate of transpiration in plants
13. State **two** roles of adrenaline in man
14. Explain why a rat, though small eats more frequently than an elephant
15. Active yeast cells were added to dilute sugar solution in a container. The mixture was kept in a warm room. After a few hours bubbles of a gas were observed escaping from the mixture
 (a) Write an equation to represent the chemical reaction above
 (b) State **two** economic importance of this type of chemical reaction in industry?
16. (a) Give **two** reasons why fats are not the main respiratory substrates in the body of a mammal and yet they give a lot of energy when oxidized.
17. The equation below summarizes a metabolic process in plants.
 Glucose \longrightarrow Ethanol + carbon (IV) oxide + Energy
 State **two** industrial applications of the above equation.
18. (a) Differentiate between respiration and respiratory surface.
 (b) Why is an effective respiratory system often associated with a circulatory system.
19. State **two** reasons why lipids are rarely used as a respiratory substrate compound to carbohydrates.
20. The equation below shows respiration for a certain food substrate. Study it and answer questions that follow:

$$2C_{51}H_{98}O_6 + 145O_2 \longrightarrow 102CO_2 + 98H_2O$$
 (a) Calculate the respiratory Quotient, RQ
 (b) Suggest with reasons the possible food substrate
21. The apparatus below was used to investigate anaerobic respiration:-

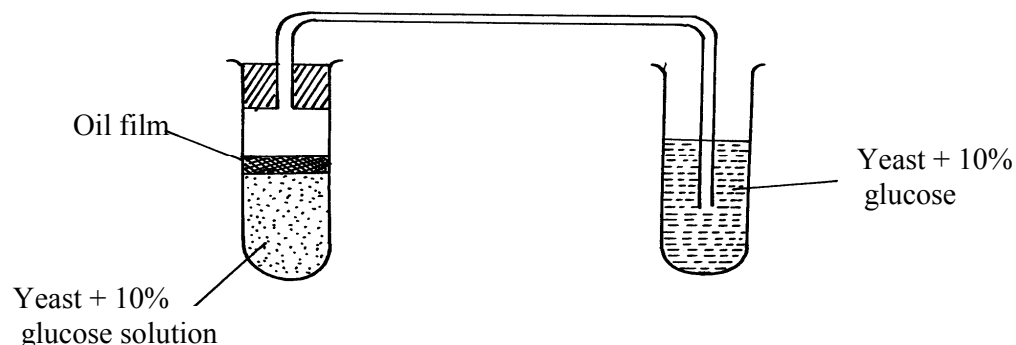

- (a) How would you remove dissolved oxygen from the glucose before the experiment commencing?
- (b) State what happens to the lime water as the experiment proceeds to the end
- (c) Describe the reactions in the experiment
- (d) Explain what would happen if the temperature of glucose solution and yeast was raised beyond 45°C?

8. Excretion and homeostasis

1. Explain the following:-
 - i) Fresh water fish excrete ammonia
 - ii) Glucose is absent in urine yet present in glomerular filtrate
2.
 - (a) State **two** functions of the kidney
 - (b) Name **two** substances that are not found in urine of a healthy person
 - (c) Name **two** diseases that affect the kidney
3.
 - (a) State **two** structural modification of the kidneys of deserts animals like kangaroo rat.
 - (b) Describe how ingestion of very salty food may reduce the amount of water excreted in urine.
4. A student mixed a sample of urine from a person with Benedict’s solution and heated, the colour changed to orange.
 - (a) What was present in the urine sample?
 - (b) What did the student conclude on the health status of the person?
 - (c) Which organ in the person may not be functioning properly?
5. (a) If the human pancreas is not functional:-
 - (i) Name the hormone which will be deficient
 - (ii) Name the disease the human is likely to suffer from
- (b) What is diuresis?
6. State **one** structural adaptation of nephron in the kidney of a desert mammal
7. Name the nitrogenous wastes excreted by the following organisms:-

Animal	Nitrogenous Waste
(i) Desert mole	
(ii) Marine fish	
(iii) Tilapia	

8. The table below shows description of sizes of glomeruli renal tubules of two animals which are living in different environments

	Animal X	Animal Y
Glomeruli	Large and few	Small and many
Renal tubules	Short	Long

- (a) Name the likely environment in which each animal lives:
 - (i) Animal X
 - (ii) Animal Y
- (b) What role does vasoconstriction play in thermoregulation?
9. The table below shows the approximate percentage concentration of various components in blood plasma entering the kidney, glomerular filtrate and urine of a healthy human being

Component	Plasma	Glomerular filtrate	Urine

Water	90	90	94
Glucose	0.1	0.10	0.00
Amino acids	0.05	0.05	0.00
Plasma proteins	8.0	0.00	0.00
Urea	0.03	0.03	2.00
Inorganic ions	0.72	0.72	1.50

- (a) Name the process responsible for the formation of glomerular filtrate
 (b) What process is responsible for the absence of glucose and amino acids in urine?
 (c) Explain why there are no plasma proteins in the glomerular filtrate?
- What is the importance of sebaceous glands in the human skin?
 - Explain why sweat accumulates on a person's skin in a hot humid environment
 - Distinguish between diabetes mellitus and diabetes insipidus
 - State **two** processes through which plants excrete their metabolic wastes.
 - The figure below shows a vertical section through a mammalian kidney.

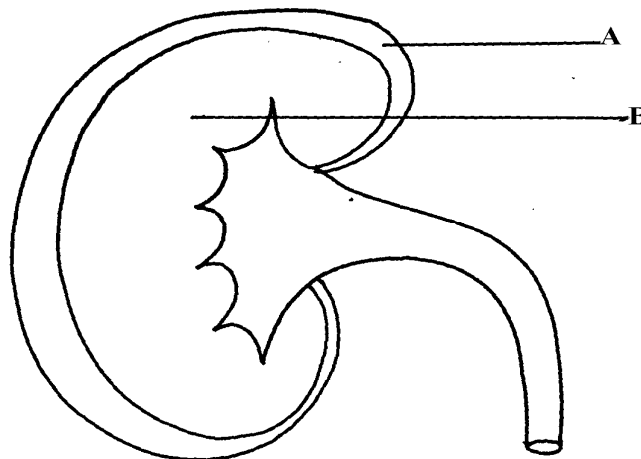

- Label the parts A and B
 - Which part is the Bowman's capsule found?
- Explain the effects of the production of large amounts of Antidiuretic hormone in the human body
 - State **two** functions of the loop of Henle
 - Study the homeostatic scheme below:

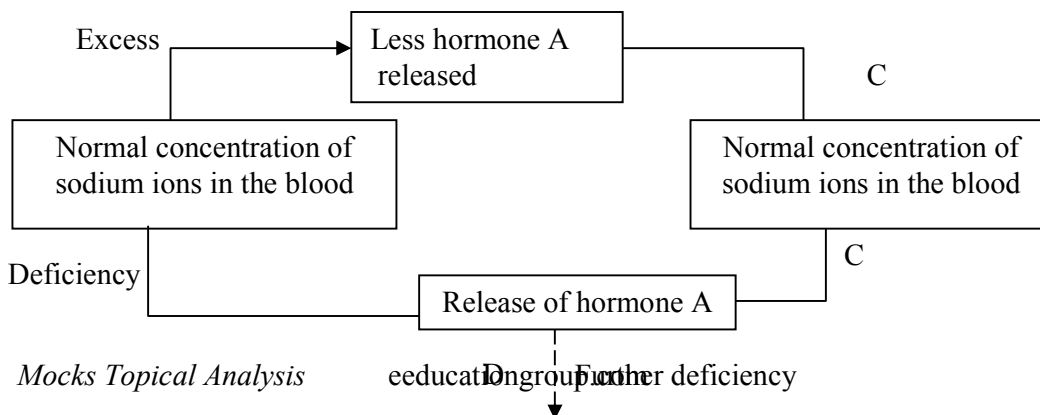

- (a) Identify the hormone labeled **A**
 (b) Name the site of action of hormone **A**
 (c) Identify the feedback labeled **D**
17. State **three** importance of Osmosis in plants
18. A patient was complaining of thirst most of the times. A sample of the patient's urine was found not to contain a lot of sugar but was dilute:-
 (a) Name the hormone the person's body was deficient of
 (b) Which gland produces the above hormone
 (c) Name the disease that the patient was most likely suffering from
19. State **two** features in the nephron that facilitate ultra filtration
20. The table below shows a description of size of glomeruli and renal tubules of two animals which are adapted to living in different environment:-

	Animal A	Animal B
Glomeruli	large and few	small and many
Renal tubules	short	long

- a) Name the likely environment in which animal **A** lives
 b) Suggest the main nitrogenous waste produced by animal **B**
 c) Name the organelle of osmoregulation in each of the following animal: i) Paramecium
 ii) Insects
21. What role is played by the liver in excretion?
22. The equation below represents a metabolic process that occurs in the mammalian liver:
 Amino acids $\xrightarrow{\text{Enzymes}}$ organic compound + urea
 a) Name the process
 (b) What is the importance of the process to the mammals?
23. A person was found to pass out large volume of dilute urine frequently. Name the:-
 (a) disease the person was suffering from?
 (b) hormone that was deficient
24. Explain the effects of the following on the quantity and composition of urine
 (a) Drinking large amount of clean water
 (b) Drinking very salty soup
 (c) Removal of pancreas
25. (a) Distinguish between **excretion** and **egestion**
 (b) State the importance of excretion in the bodies of living organisms.
26. The diagram below shows simplified structures of kidneys from two different animals.

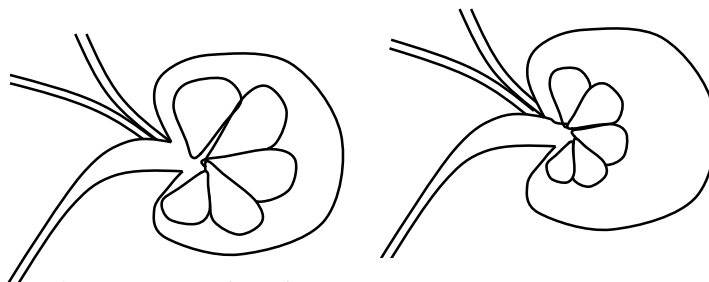

Animal N

Animal M

- (a) Suggest possible habitat in which animal N is found.
 (b) Give **two** reasons for your answer in (a) above.
27. (a) What is poikilotherm?
 (b) State **two** classes of phylum chordata where all members are poikilothermic .
28. The diagram below represents a mammalian nephron

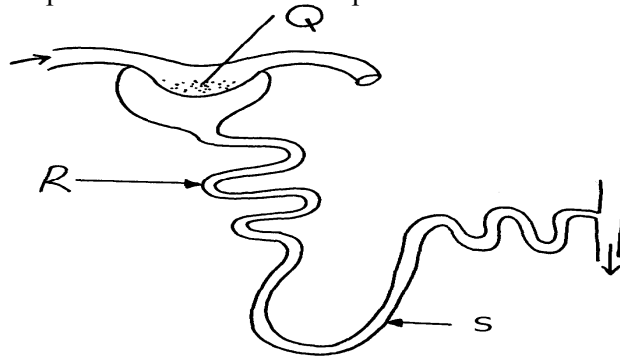

- (i) Name the structure labelled Q
- (ii) State **two** adaptations of part labeled R
29. Distinguish between internal environment and external environment as used in
30. The diagram below represents a nephron of a mammal:

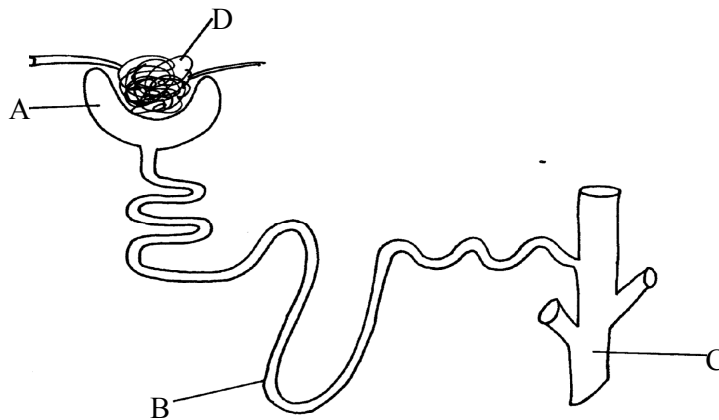

- (a) Name the parts labeled A, B and D
- (b) Name a major substance in glomerular filtrate whose concentration remains the same between A and C
31. Name the parts of the flower that are responsible for the production of gametes
32. The equation below represents a metabolic process that occurs in a certain organ in the mammalian body:-

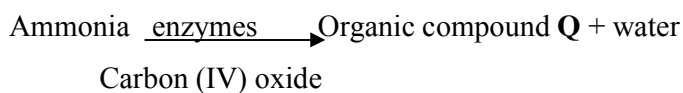

- a) Name the process represented in the equation.

- b) Name the organ in which the process occurs.
 - c) Why is the process important to the mammal?
 - d) Identify the organic compound **Q**.
 - e) Explain the source of ammonia in the organ named in **(b)** above.
 - f) What happens to organic compound **Q**?
33. Kosgei and Onyancha collided during a football match and each got bruised. Kosgei's bruise stopped bleeding after ten minutes while Onyancha's bruise continued bleeding and he had to be taken to hospital for treatment.

- (a) Explain the process which brought about stoppage of Kosgei's bleeding
 - (b) Distinguish between blood clotting and haemagglutination.
 - (c) Name the disease, that Onyancha could be suffering from.
34. The table below shows the percentage of some substances in the glomerular filtrate and urine of a certain mammal:-

Substances	Contents in glomerular filtrate	Contents in urine
Water	90	90
Sodium ions	0.3	0.35
Chloride ions	0.37	0.60
Glucose	0.1	0.0
Urea	0.03	2.0
Proteins	0.0	0.0

- (a) From the above table, account for ; (i) The absence of glucose in urine
(ii) The absence of protein in both glomerular filtrate and urine
 - (b) Explain the significance of the flow system in the nephron where the glomerular filtrate flows in opposite direction to that of blood in the surrounding capillaries
 - (c) Name the hormone that controls the percentage of water in urine and that which control the amount of salts
- Percentage of water
Amount of salts
- (d) List any **two** diseases /disorders of the kidney
35. Study the diagram below and answer the questions that follow

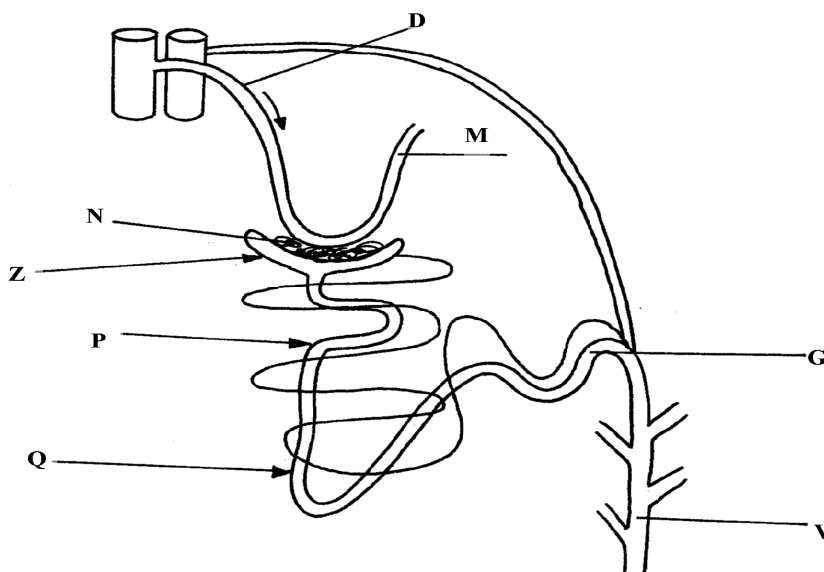

- (a) Name the structure represented by the diagram
 (b) (i) Name the parts labelled **D** and **M**
 (ii) Name the hormones whose sites of action are **Q** and **G**
 (c) Name **one** substance that is present in part **N** but absent in part **Z**
 (d) The contents of part **V** were boiled with Benedicts' solution and an orange precipitate was formed. Account for the results
36. In an investigation, two persons **A** and **B** drank the same amount of glucose solution. Their blood sugar levels were determined immediately and thereafter at intervals of one hour for the next six hours.

The results were as shown in the following table:-

Time (hrs)	Blood glucose level (mg/100ml)	
	Person A	Person B
0	90	120
1	220	360
2	160	370
3	100	380
4	90	240
5	90	200
6	90	160

- (a) Draw a graph of blood sugar levels of persons **A** and **B** against time on the same axis
 (b) Explain each of the following observations;-
 (i) Blood sugar level increased in person **A** between 0 and 1 hour
 (ii) The blood sugar level dropped in person **A** between 1 and 4 hours
 (c) From the graph, what is the normal blood glucose sugar level for human beings
 (d) Suggest a reason for the high sugar level in person **B**
 (e) How can the high blood sugar level in person **B** controlled?
 (f) What is the biological significance of maintaining a relatively constant sugar level in a human being
 (g) Account for the decrease in the blood glucose level of person **B** after 4 hours
37. An experiment was carried out to determine the effect of drinking on excess amount of water on the flow of urine. A person drinks one litre of water and urine was collected at intervals of 15minutes.

The results were as shown below:

Time in minutes	0	15	30	45	60	75	90	105	120	135
Urine output ml/min	1.6	1.6	1.6	5.4	9.0	9.0	7.6	3.0	0.8	0.8

- (a) Plot a suitable graph to represent urine output with time.
 (b) Explain the rate of flow of urine between the following times;
 (i) 15 and 60minutes.

(ii) 60 and 75minutes.

(iii) 75 and 135 minutes.

(c) Name **two** hormones responsible for regulation of relative amount of salts and water in man.

38. a) Explain how urea is formed in the human body

b) Describe the path taken by urea from the organ where it is formed until it is released from the human body

39. The diagram below represents a mammalian nephron.

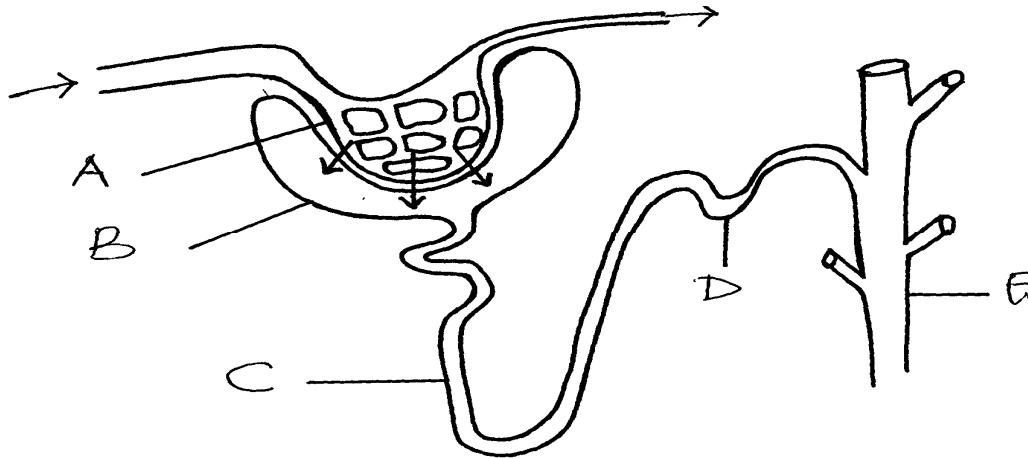

(a) Name the structures labeled **B,C** and **D**

(c) Name the process by which substances are reabsorbed from structure **C** into blood capillaries

(d) How is the pressure in structure **A** achieved?

40.

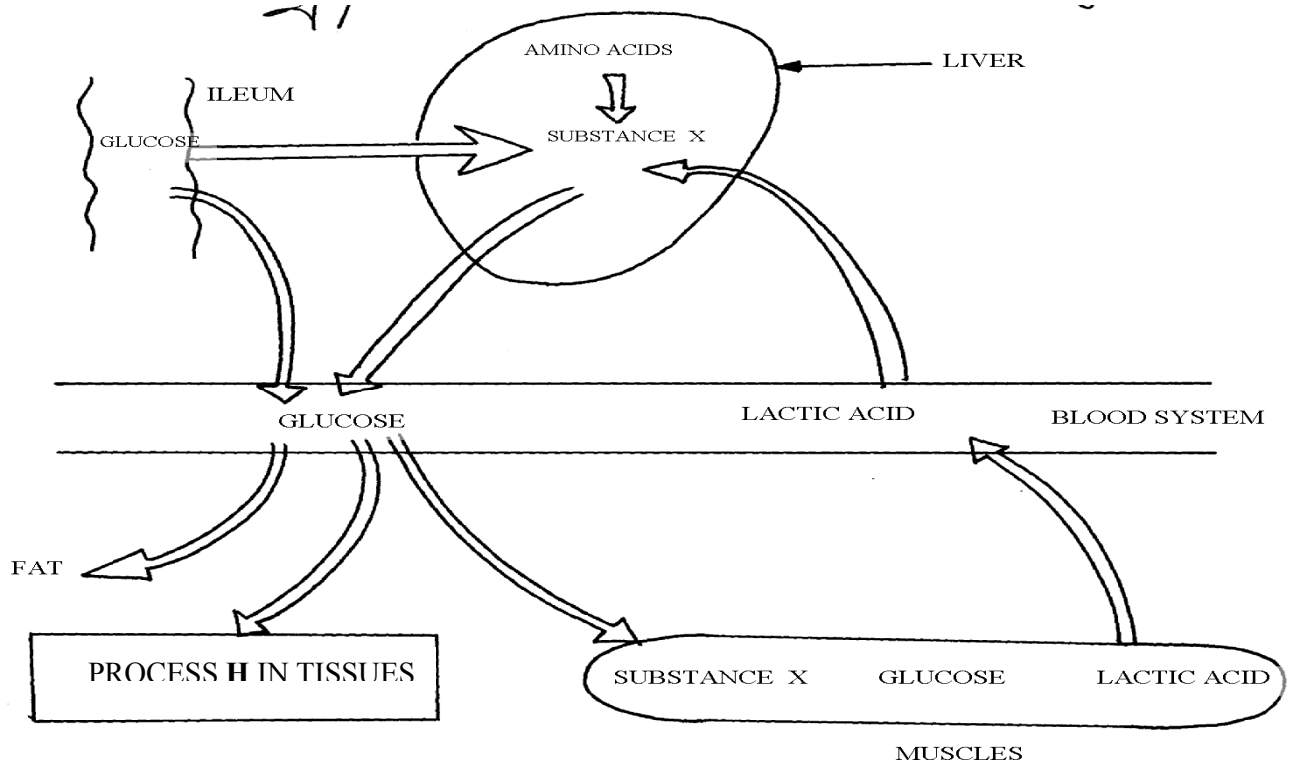

- Identify **substance X**
- Give the end products of the process labelled **H**
- Give **three** other functions of the liver

41. The flow diagram below represents blood clotting process

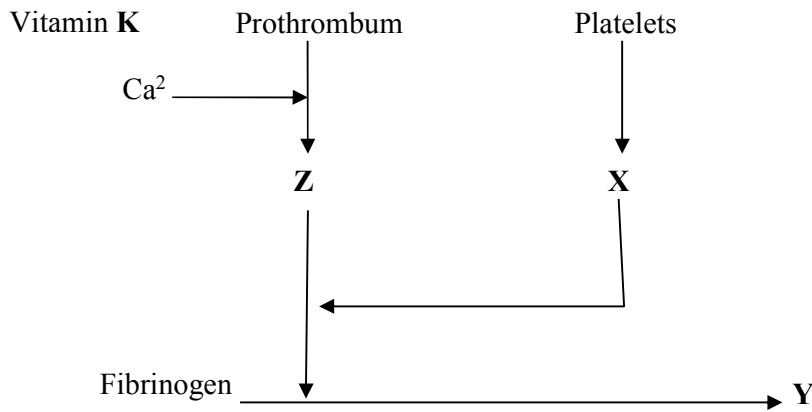

- Name the proteins represented by the letters; V, Y, Z
- State the importance of blood clotting
- Why doesn't the physiological process above occur in undamaged blood vessels

42. How does an Endotherm respond to both heat gain and heat loss?

43. The diagram below represents a mammalian nephron

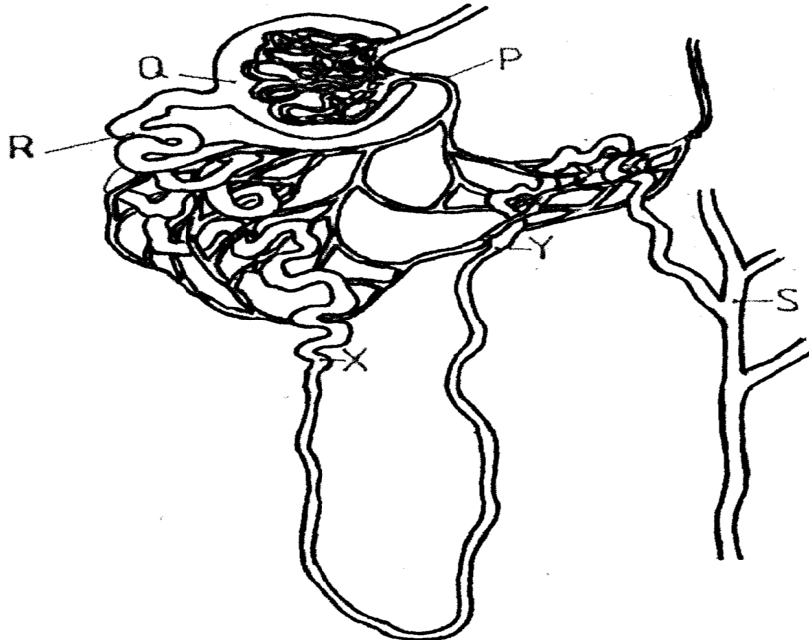

- (a) Name the: (i) Structure labelled **P**
- (b) State the structural modifications of the part label led **Q** for
 (i) Desert mammals
 (ii) Fresh water mammals
- (c) (i) Name **one** substance present at point **R** but absent at point **S** in a healthy mammal.
 (ii) The appearance of the substance you have named in (c)(i) above is a symptom of a certain disease. Name the disease
44. Describe how the mammalian skin regulates body temperature

9. Ecology

1. A student wanted to estimate the number of grasshoppers in 5km² grass field near the school compound.

Using a sweep net he captured 36 grasshoppers. He used a red felt pen to mark the thorax of each insect before releasing back into the field. Three days later he made another catch of grasshoppers. He collected 45 grasshoppers of which only 4 had been marked with red mark.

- a) Name the above method used in the population estimation
 b) Calculate the population of grasshoppers using the above data
2. What is the significance of the following in the ecosystem?

- a) Decomposers
- b) Predators
- 3. Birds feed on grasshoppers that feed on grass.
 - a) Draw a possible food chain from the above information
 - b) Explain why the biomass of organisms decreases at each preceding trophic level.
- 4. Define the following terms:-
 - (i) Autecology;
 - (ii) Biomass;
- 5. State **two** most important factors that favour exponential growth of a population of gazelle in a park
- 6. (a) Distinguish between habitat and niche.
(b) Explain why Biomass of producers is greater than that of primary consumers in a balanced ecosystem.
(c) State **two** advantages of a biological control method over the chemical control method of pests and parasites
- 7. Explain how oil as a pollutant may affect aquatic plants and animals?
- 8. The diagram below shows part of a food relationship in an ecosystem:-

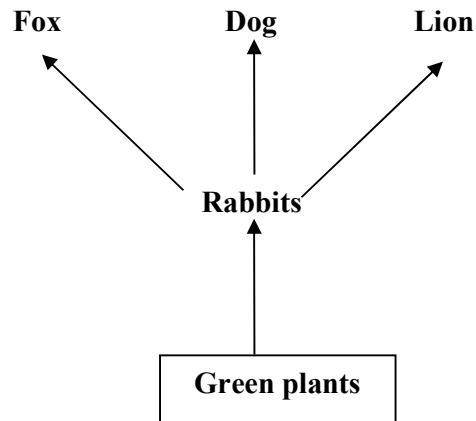

- (a) Name the food relationship above
- (b) How many trophic levels are shown in the diagram above?
- (c) State main source of energy in the ecosystem
- 9. Use the food web below to answer the questions that follow:-

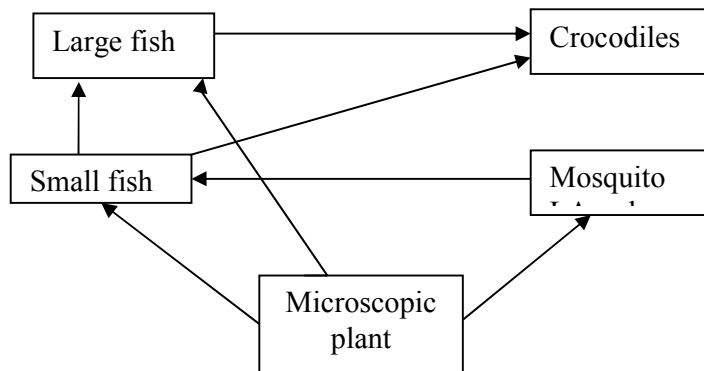

- (a) Construct a food chain ending with crocodile as a quaternary consumer
- (b) Name the organisms in the food web that has only one predator

10. 50 black mice and 50 white mice were released in an area inhabited by a pair of owls. After four months, the mice in the area were recaptured and only 38 black mice and only a white mice remained.

- (a) How would you explain these results?
- (b) Name the theory of evolution that support the results in (a) above

11. In a certain school Form three class did an experiment to estimate the number of Tilapia in their fish pond. 725 tilapia were netted marked and released.

- a) State the method used in this exercise
- b) Calculate the tilapia population.
- c) State **two** assumptions made by the students during the investigation

12. An investigation was carried out on a terrestrial ecosystem. The population sizes and species biomass were determined and recorded as shown in the table

SPECIES	POPULATION SIZE	SPECIES BIOMASS
A	1×10^3	1×10^3
B	1×10^3	1×10^{-1}
C	1×10^5	1×10
D	1×10	1×10^4

- a) If these organisms had a feeding relationship, construct a simple food chain involving all the organisms
- b) Construct pyramid of numbers using the data provided above
- c) State **one** disadvantage of using pyramid of number in expressing feeding relationships in ecological ecosystem

13. The figure represents a feeding relationship in an ecosystem

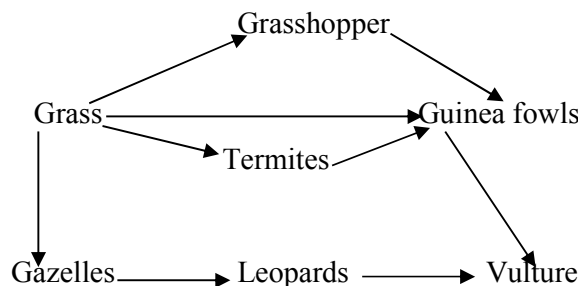

- (a) Write down the food chain in which the Guinea Fowls are secondary consumers
- (b) What would be the short term effects on the ecosystem if lions invaded the area
- (c) Name the organism through which energy from the sun enters the food web

14. Outline **three** roles of active transport in human body

15. Distinguish between community and population

16. Describe how the belt transect can be used in estimating the population of a shrub in a grass land

17. A fish farmer wanted to know the number of fish in a pond. He collected 10 fish from the pond and labeled each, by a tag label on its fin and returned the ten fish to the pond to mix with other fish. When he later collected 50 fish from the pond, he found only four of them had labels

- a) Estimate the total number of fish in the pond (show your workings)
- b) What **two** assumptions are being made in this methods of estimating population

18. What is the importance of saprophylic fungi and bacteria in an ecosystem

- 19. i) Name **one** main cause of global warming
- ii) What are the effects of global warming

- 20. Explain how saliva is important in digestion
- 21. Give a reason why two species in an ecosystem cannot occupy the same niche
- 22. Below is a pyramid of numbers indicating trophic levels:-

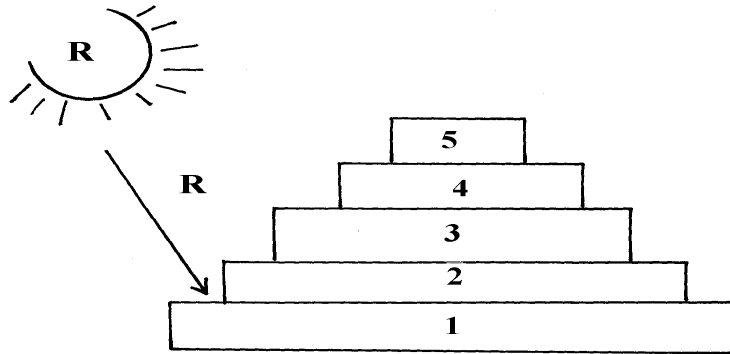

- (a) What do you understand by the term trophic level?
 - (b) Name the trophic level numbered 5 on the pyramid
 - (c) Name Q
 - (d) What is the significance of the arrow R
- 23. Two populations of the same species of birds were separated over a long period of time by an ocean. Both populations initially fed on insects only. Later, it was observed that one population fed entirely on fruits and seeds, although insects were available. Name this type of evolutionary change
 - 24. To estimate the population size of crabs in a certain lagoon, traps were laid at random. 400 crabs were caught, marked and released back into the lagoon. Four days later, traps were laid again and 360 crabs were caught. Out of the 360 crabs, 90 were found to have been marked
 - (i) Calculate the population size of the crabs in the lagoon
 - (ii) What is the name given to this method of estimating the population size
 - 25. State the function of each of the following apparatus:
 - (a) Pooter ...
 - (b) Sweep net
 - 26. State the role of the following apparatus in the study of living things.
 - (a) Sweep nets.
 - (b) Pooter.
 - (c) Pit fall trap.
 - 27. Name **three** density dependent factors in an ecosystem.
 - 28. (a) What are the **two** main components of an ecosystem?
(b) Apart from mere observation of actual feeding suggest **two** methods that can be used to determine the type of food eaten by animals
 - 29. The chart below represents a simplified nitrogen cycle.

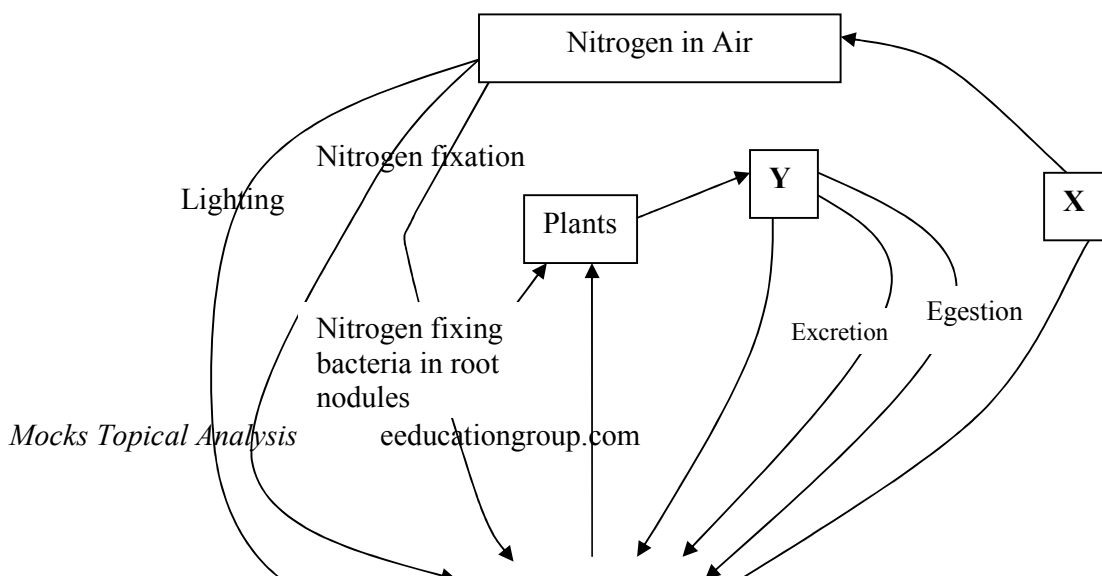

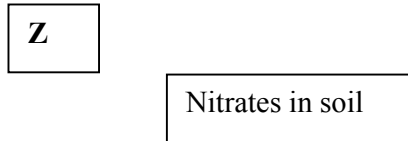

What is represented by X, Y and Z?

30. In an ecological study, a locust population and that of crows was estimated in a grassland area over a period of one year. The results were tabulated as shown below.

Months	J	F	M	A	M	J	A	S	O	N	D
No. of Adult locusts x 10 ²	90	20	11	25	200	652	15	10	35	192	456
Number of crows	4	2	0	1	8	22	2	1	1	5	15
Amount of rainfall	20	0	55	350	520	350	10	25	190	256	350

- Draw a graph of population of locusts and crows against time
 - State the relationship between rainfall and locust population
 - Account for the relationship you have stated in b (i) above
 - What happens on the populations of locusts and crows in the months of January to March? Give a reason.
 - If the area of study was one square kilometer, state **one** method used to estimate the population of :-
 - Locusts
 - Crows
 - State the trophic levels of the (i) Locusts and (ii) crows
 - Construct a simple complete food chain involving these organisms
 - If the locust were removed from the food chain, what would be its effect?
 - Define **biomass**
31. Two species of antelopes were introduced into an ecosystem at the same time in equal numbers. The graphs below show their relative numbers during the first eight years of their co-existence. Study the graphs carefully and answer the questions that follow.

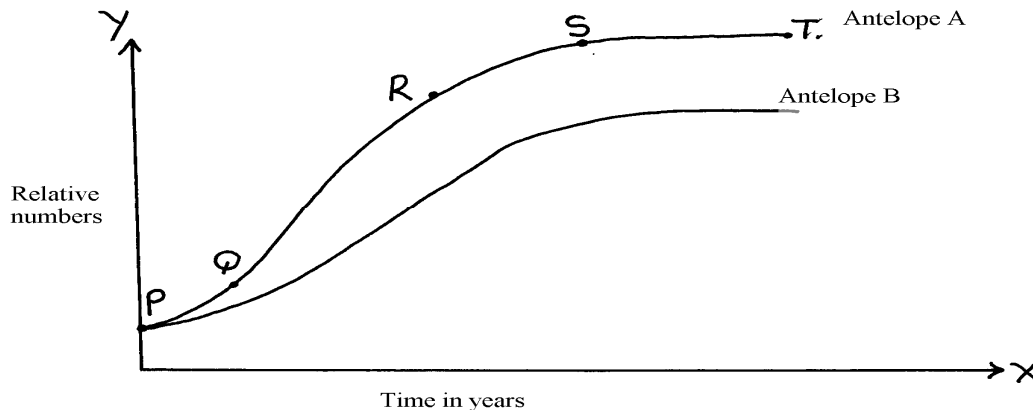

- Which species of antelope has better survival adaptations.
 - Give a reason for your answer above.
- Name the type of curves shown.
 - Name the phases labeled PQ, QR, RS, ST
- Explain the shape of the curve for the species of Antelope A between
 - Q and R.

ii) **S** and **T**.

- d) i) State the type of competition shown by the two species of antelopes.
 ii) State any **two** symptoms of intraspecific competition in plants.
- e) Suggest how the species B avoid competitive exclusion..
- f) State any **three** adaptations that enable the antelopes to overcome predation.
- g) State any **two** possible methods by which populations of the two antelopes' species were determined.
32. Explain **five** abiotic factors that affect the ecosystem
33. The data shown below was taken from Savannah grassland habitat. Examine it carefully and then answer the questions that follow:-
- (a) Draw **three** food chains
- (b) Draw a pyramid of numbers for a food chain with four trophic levels and indicate the trophic levels at which each member feeds
- (c) State the effect of removing the hunting dogs
- (d) Why is it advisable to feed 100kg of grain to man instead of using it to fatten steers then supply beef to human population?

Organism	Population
Grasses	1000
Caterpillars	500
Squirrels	300
Frogs	200
Gazelles	300
Elephants	100
Snakes	50
Hunting dogs	40
Vultures	40
Lions	40
Hawks	10

34. Study the following food web and answer questions that follow:

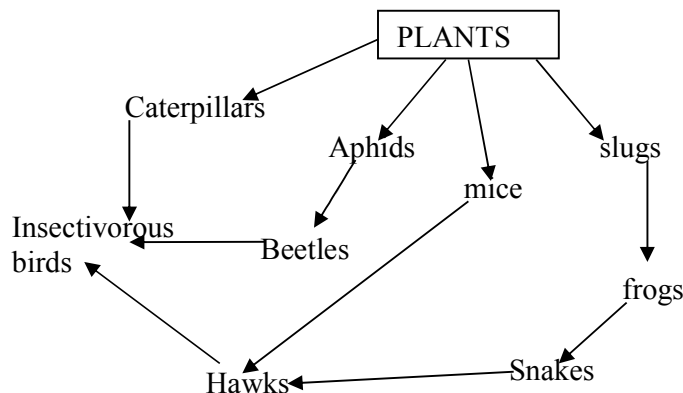

- (a) (i) Name the organisms that occupy the second trophic level
 (ii) What is the other name for the second trophic level
- (b) Write down **two** food chains from the food web that:
 (i) End with hawks as tertiary consumer
 (ii) End with hawks as quaternary consumer
- (c) Giving reasons state; (i) the organism with largest biomass
 (ii) the organism with least biomass
35. (a) Explain how food as a factor regulates the population of animals in an ecosystem
 (b) Describe the flow of energy from the sun through the different trophic levels in an ecosystem
36. (a) Describe how a population of grasshoppers in a given area can be estimated
 (b) Describe how the belt transect can be used in estimating the population of a shrub in a grassland
37. The flow chart below represents a feeding relationship in an ecosystem

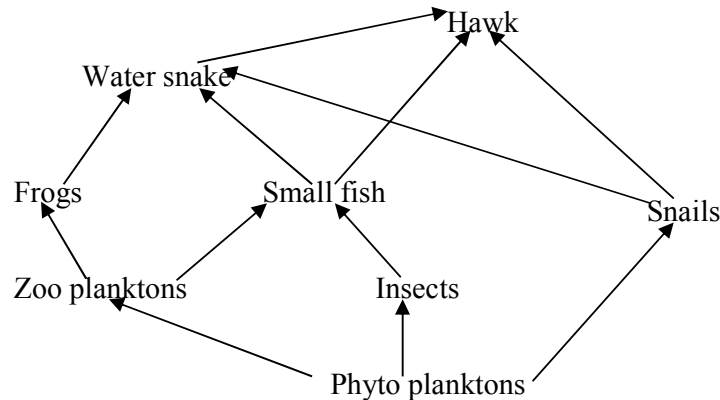

- (a) Name; (i) The producers in the ecosystem
 (ii) Two organisms which are both secondary and tertiary consumers
- (b) State **two** short term effects of immigration of insects in the ecosystem.
- (c) Which organism has the least Biomass in the food web. Explain.
- (d) State **three** disadvantages of using synthetic pesticides over Biological control.
- (e) State the role of each of the following in an ecosystem;
 (i) Saprophytes
 (ii) Leguminous plants
 (iii) Explain the role of producers in an ecosystem
- (f) Name **one** method that would be used to estimate the population of small fish in the ecosystem
38. How are leaves of mesophytes adapted to their functions?

10. Reproduction in (a) plants (b) animals

1. a) Name the part of an ovule that develops into each of the following parts of a seed after fertilization
 i) Testa
 ii) Endosperm
- b) What is parthenocarpy?
2. State **three** roles of placenta during pregnancy.

3. Name **three main** methods through which HIV/AIDS is transmitted
4. (a) Name the processes that lead to fruit formation without fertilization
(b) Name the hormone that causes leaf, flowers and fruit abscission
(c) What is the role of ecdysone hormone in insects
5. State the roles of oviduct in female reproductive system
6. The diagram below represents a mature embryo sac. Study it carefully and answer the questions that follow:

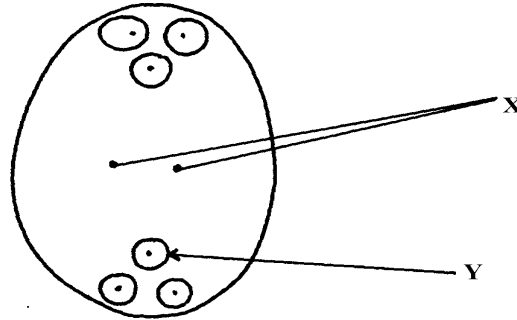

- (a) Identify structures **X** and **Y**
- (b) Why is cross pollination more advantageous to a plant species than self pollination?
7. The diagram below shows a phenomenon which occurs during cell division.

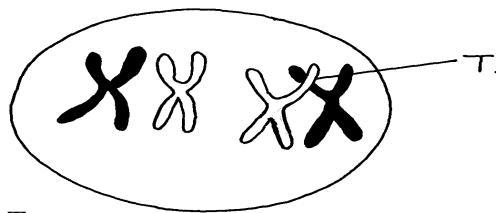

- (a) Name the part labeled **T**.
- (b) (i) State the biological importance of the part labelled **T**.
(ii) Identify the type of cell division in which this phenomenon occurs.
8. (a) When are the **two** organisms considered to belong to the same species.
(b) Explain the term **alternation of generations**.
9. (a) Explain why Larmack's Theory of evolution is not accepted by biologists today.
(b) State the significance of mutation in evolution.
10. (a) Give **two** roles of the placenta.
(b) Explain why hormone testosterone still exerts its influence even when vas deferens have been cut.
11. Name **two** mechanisms that hinder self fertilization in flowering plants
12. State **three** ways in which plants compensate for lack of movement
13. (a) What do you understand by the term double fertilization?
(b) State **two** adaptations of animal dispersed fruits
14. Name the hormone that;
(a) Stimulate the contraction of uterus during birth
(b) Stimulates the disintegration of the corpus inteum when fertilization fails to take place
15. State **three** ways in which flowers parent self pollination
16. The diagram below represents a stage in the development of human foetus

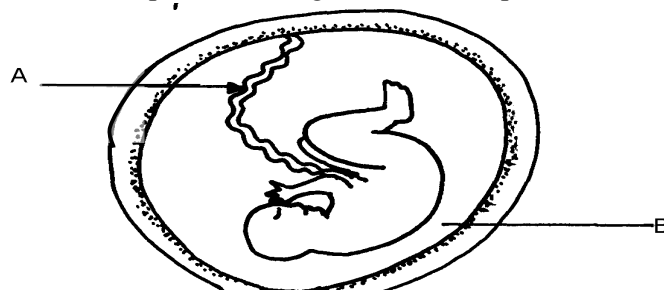

- (a) State **one** function of each of the structures labelled **A** and **B**
 (b) Apart from the size of the foetus what else from the diagram illustrates that birth was going to occur in the near future
 (c) Explain why a pregnant woman is supplied with doses of iron tablets regularly
17. Name the type of placentation where;
 (i) Placenta appears as one ridge on the ovary wall
 (ii) Placenta appears at the centre of the ovary with ovules on it and the dividing walls of carpels disappear
18. The diagram below represents a mature fruit from a dicotyledonous plant, observe it and answer questions that follow

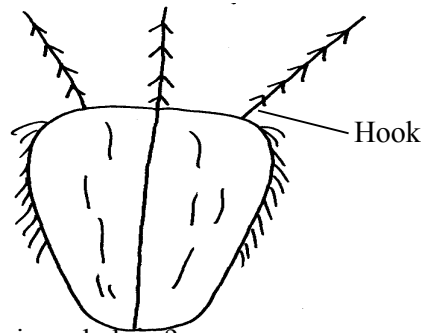

- a) To what group of fruits does the specimen belong?
 b) Suggest the possible agent of dispersal of the fruit
19. Explain why menstrual periods stop immediately after conception?
20. a) Why is sexual reproduction important in evolution of plants and animals
 b) The calyx cells of a certain plant has 22 chromosomes. State the number of chromosomes present in the plant's
 i) Endosperm
 ii) Ovule cell
21. The diagram below shows a pollen – tube entering the ovule of a flowering plant

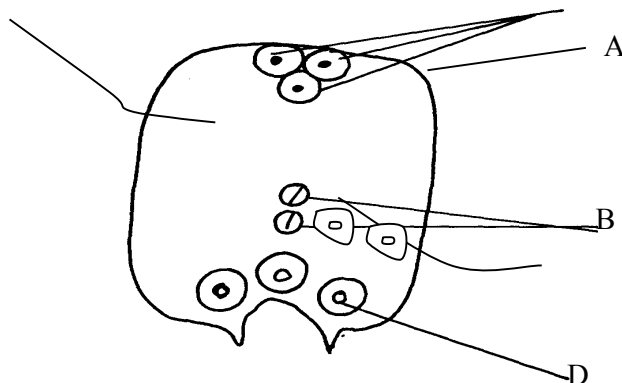

- a) Name the parts labeled **A**, **B** and **D**

- b) Name the kind of fertilization exhibited by the above flowering plant.
22. Donkey and zebra are closely related yet not of the same species. Explain
23. Name **two** factors in the environment which organisms respond to
24. What is meant by the terms:-
 a) i) Epigynous flower
 ii) Staminate flower
 b) Name the protective membranes surrounding the brain
25. The diagram below illustrate a process in a given species of organism

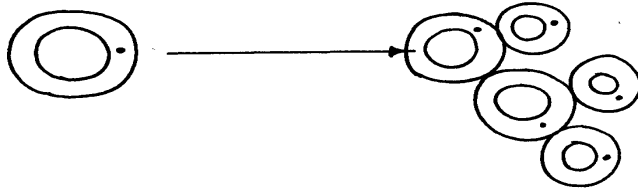

- a) Name the organism that undergoes the process above
 b) Identify the process shown to be taking place
26. State **two** ways by which HIV/AIDS is transmitted from mother to child
27. (a) State the role of centrioles during cell division
 (b) (i) Explain the role of chlorophyll in photosynthesis
 (ii) What is the **main** product of the dark stage of photosynthesis?
28. (a) At what stage of meiosis is the chiasmata formed?
 (b) (i) What is the significance of the above part in living organisms?
 (ii) State **two** importance of meiosis in living organisms?
29. (a) State **two** ways in which the male parts of a wind pollinated flower are adapted to their mode of pollination
 (b) Differentiate between monoecious and dioecious plants
30. (a) What is seed dormancy?
 (b) State **two** ways in which seed dormancy can be broken
31. (a) Explain **two** importance of the adult stage in metamorphosis in insects
 (b) What is the importance of the juvenile hormone in insects?
32. Describe the possible effects of discharging hot effluent from a factory into a slow flowing river
33. State **two** disadvantages of external fertilization in animals
34. State **three** roles of placenta in mammals
35. (a) The diagram below shows a stage during cell division

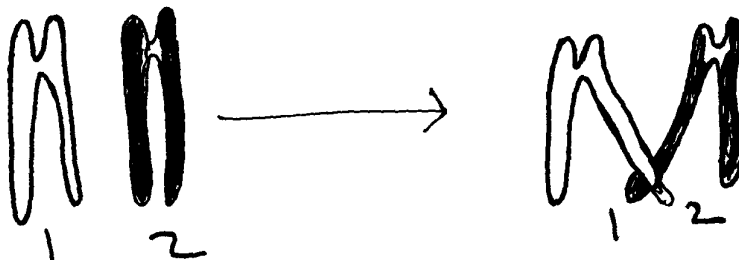

- (i) Name the stage of cell division
 (ii) Give a reason for your answer

- (b) Name **two** structures in plants where male and female gametes are produced
36. State **two** advantages of metamorphosis to the life of insects
37. List **four** differences between Mitosis and Meiosis
38. Give a reason why two species in an ecosystem cannot occupy the same niche
39. State the functions of the following hormones in the menstrual cycle :
(i) oestrogen
(ii) luteinizing hormone (L.H)
(iii) Follicle stimulating hormone (FSH)
40. The diagrams below represent two gynoecia **A** and **B** obtained from two different plants.

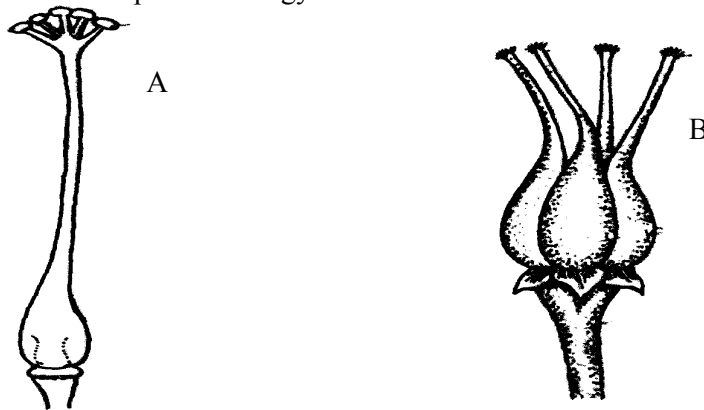

- (a) What name is given to; Gynoecium **A**?
Gynoecium **B**?
- (b) State the observable difference between the gynoecia **A** and **B**
- (c) State the role played by Heterostyly in plants.
41. State the difference between the sperm cell and the ovum.
42. (a) Name the parts of the flower in which pollen grains are formed.
(b) Name **two** nuclei found in pollen grains.
43. The diagram below represents a stage in cell division.

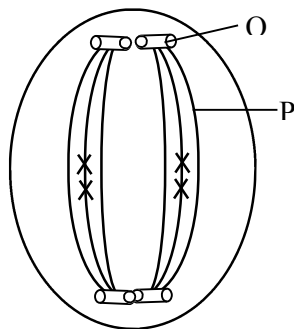

- (a) Name the stage of cell division shown in the diagram above.
(b) Give reasons for your answer.

44. Name the hormone that:

- (a) Stimulate the contraction of uterus during birth.
- (b) Stimulate the disintegration of corpus luteum when fertilization fails to take place.

45. State **three** ways in which seed dormancy benefits a plant

- 46. (i) State **two** major structural differences between fruit and a seed
- (ii) Why is it advisable to use biological control of pests?

47. State the functions of the following parts in the male reproductive system

- (a) Somniferous tubules
- (b) Sertoli cells

- 48. (a) Name the parts of a flower responsible for gamete formation
- (b) State **one** feature of pollen grains from a wind pollinated flower

49. Name the mechanisms that hinder self-fertilization in flowering plants

50. The eggs of birds are relatively much larger than those of mammals. Explain

51. Distinguish between the following terms:

Pollination and fertilization

- 52. a) Describe the various mechanisms of fruit and seed dispersal.
- b) Describe the varying events that follow a flower after fertilization.
- 53. Describe how fruits and seeds are suited to their mode of dispersal

54. The diagram below represents some hormones, their sources and functions in a mammal:

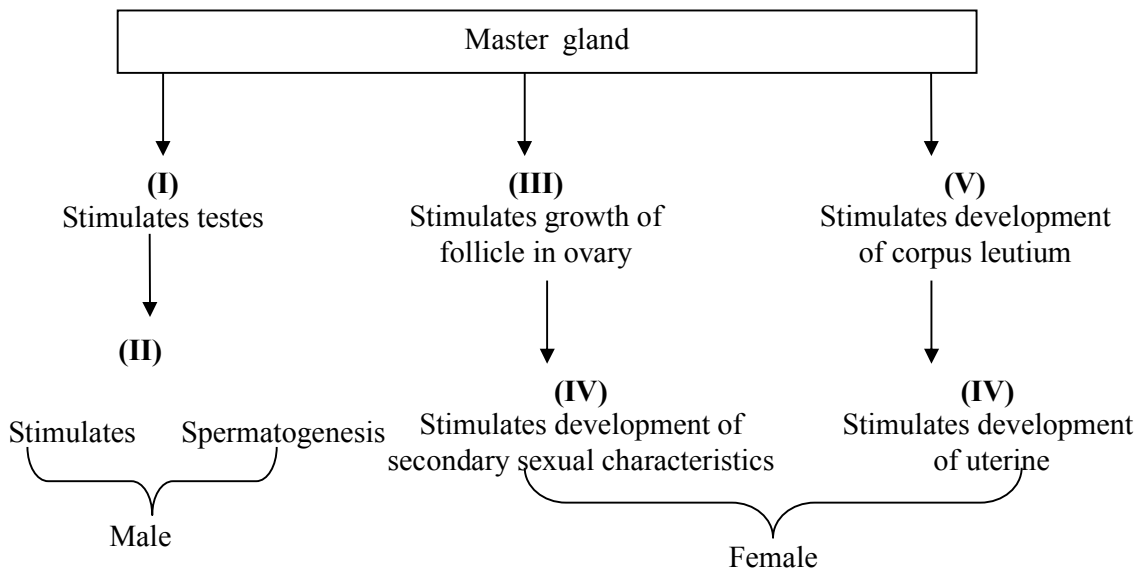

(a) Identify the master gland described above

(b) Name hormones (ii), (iii), (v) and (iv)

(c) Explain the consequences of deficiencies of hormone (ii) in man

(d) Other than stimulating the development of uterine wall, suggest one other function of hormone (vi)

55. The diagram below represents some hormones, their sources and functions in mammals.

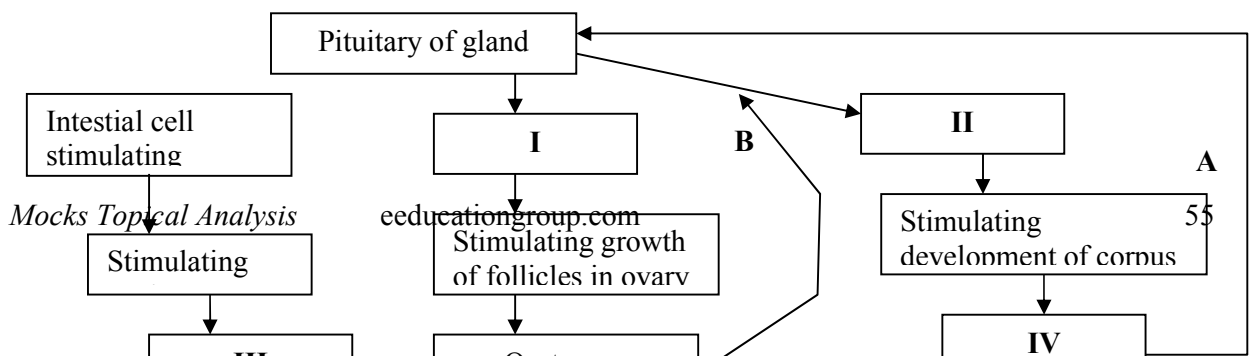

- a) Name the hormones **I, II** and **III**
 b) Name hormones **IV** and state its function
 c) Name the control labelled **A & B**
 d) Name **one** secondary sexual characteristic common to both males and females
56. (a) State the role of spleen in human defense mechanism
 (b) State **two** ways by which the HIV spread may be controlled through patients in hospitals
 (c) What do you understand by the word Acquired Immunity Deficiency Syndrome (AIDS)
 (d) Why is immunization against diseases encouraged by the government
 (e) State how natural active acquired immunity is attained by an individual
57. Explain how seeds and fruits are adapted to the various methods of dispersal
58. The diagram below represents female reproductive system;

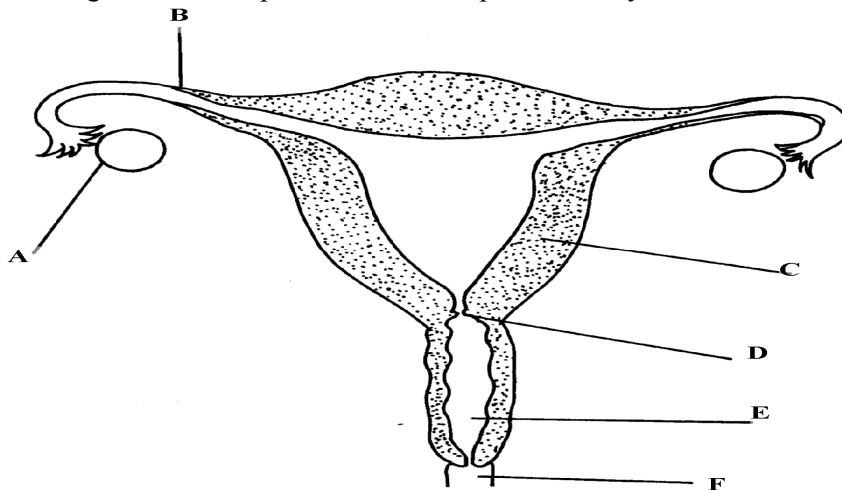

- a) Name the part labeled; A, B, C and D
 b) State **two** functions of structure A
 c) How is part C adapted to its function?
 d) Of what significance is part E to reproduction?
59. The diagram below represents a human foetus in a uterus

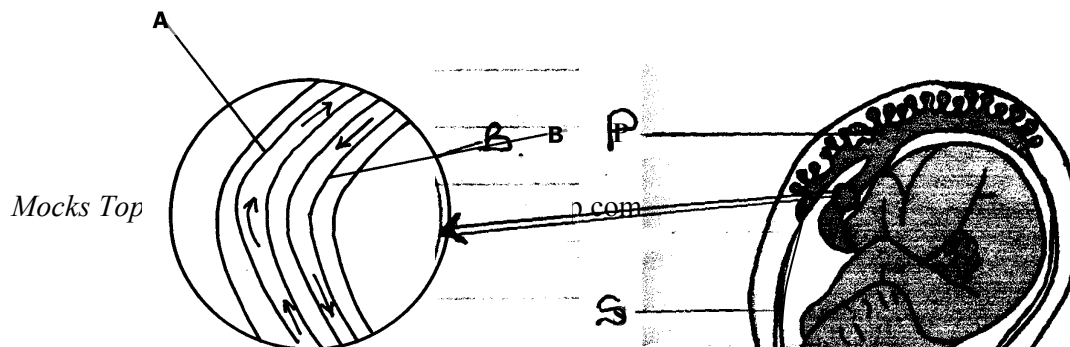

- (a) Name the part labelled **S**
- (b) (i) Name the blood vessels labelled **A** and **B**
 - (ii) State the difference in composition of blood found in vessels **A** and **B**
- (c) Name **two** features that enable the structure labelled **P** carry out its function
- (d) State the role of the part labelled **R**

60. An experiment was carried out to investigate the rate of growth of pollen tube against time.

The results are shown in the table below:

Time in minutes	Growth of pollen tube in millimeters
0	0
30	4.0
60	9.8
90	15.2
120	20.0
150	21.6
180	22.4

- (a) (i) On the grid provided draw a graph of the pollen tube growth against time.
- (b) (i) At what intervals was the growth of the pollen tube measured?
 - (ii) What was the length of pollen tube at; 130 minutes
 - (iii) At what time was the length of the pollen tube 18mm?
 - (iv) With reasons, describe the growth pattern of the pollen tube between:
 - 0 to 120minutes
 - Reason
 - 120 to 180 minutes
 - Reason
 - (v) State the importance of the growth of pollen tube to the plant
- (c) State the changes that take place in a flower after fertilization

11. Growth and development in (a) plants (b) animals

- 1. a) Name the hormone which controls moulting in insects.
 - b) State the importance of moulting in insects.
- 2. The illustration below represents an eye defect

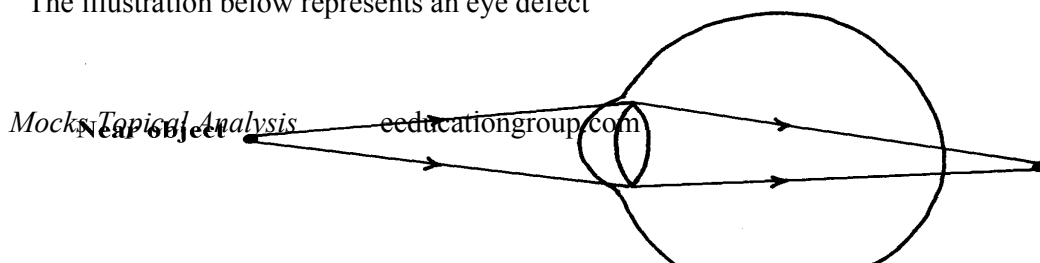

- a) Name the eye defect .
- b) Name the lenses that can be used to correct the defect.
- 3. (a) State **two** functions of the kidney
- (b) Name **two** substances that are not found in urine of a healthy person
- (c) Name **two** diseases that affect the kidney
- 4. The diagram below represents a growth pattern of arthropods.

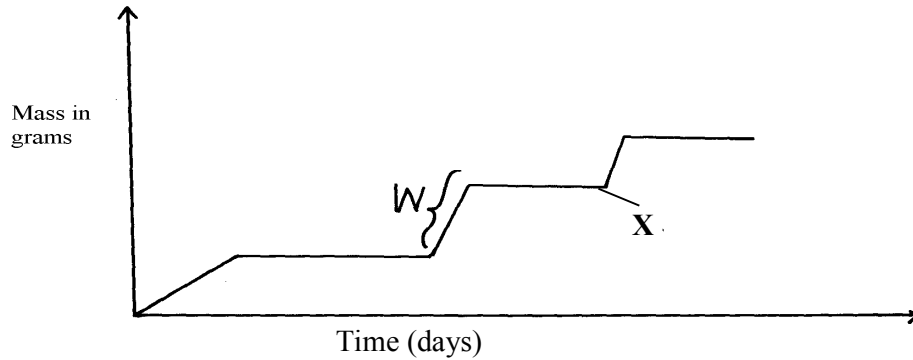

- (a) Name the type of growth pattern represented on the graph.
- (b) Identify the process represented by X.
- (c) Which hormone is responsible for process at X in 15 (b) above?
- 5. Distinguish between natural and acquired immunity.
- 6. The cells shown below were obtained from different parts of a young root tip:

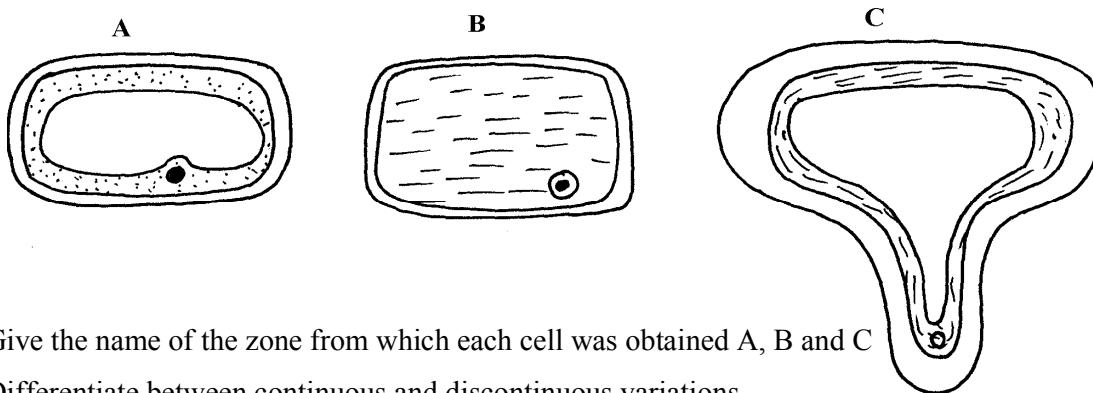

- Give the name of the zone from which each cell was obtained A, B and C
- 7. Differentiate between continuous and discontinuous variations
 - 8. An experiment was set-up as shown in the diagram below:-

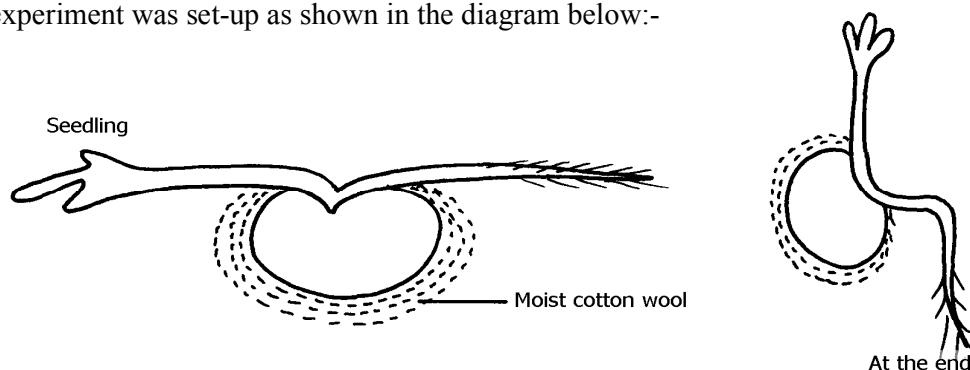

- (a) Suggest the possible aim of this experiment
 (b) Account for the observation at the end of the experiment
9. State the location of **each** of the following plant meristematic tissues:-
 (i) Vascular cambium
 (ii) Intercalary meristem
10. Define the following terms: a) Growth
 b) Development
11. State **two** advantages of metamorphosis in the life insects
12. State **one** disadvantage of exoskeleton in insects.
13. Distinguish between primary growth and secondary growth in a flowering plant
14. What is the role of the following to a germinating seed: (i) Oxygen
 (ii) Cotyledons
15. Give **three** applications of plant growth hormones in agriculture
16. State **two** functions of calcium in the human body
17. State the biological importance of ecdysis in arthropods
18. The diagram below represents a stage during the process of germination.

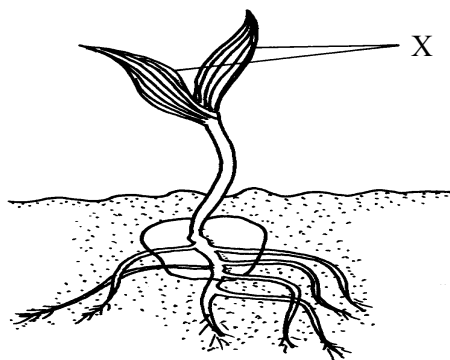

- (a) (i) Name the type of germination illustrated in the diagram
 (ii) Give a reason for your answer in (a) (i) above.
- (b) Give **two** functions of the part labelled X
19. In an experiment young potted seedlings were placed in a dark box with unilateral light source as shown below:

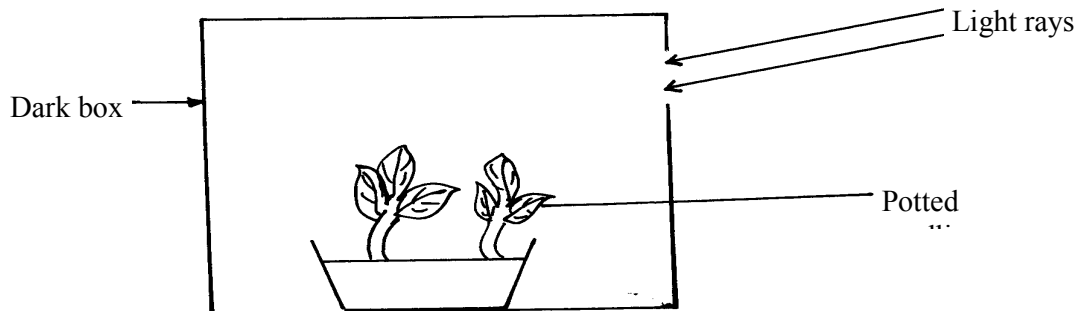

- (a) What was the aim of the experiment?
 (b) State the observations made on the seedlings after 3 days
20. The graph below represents the growth of animals in a certain phylum.

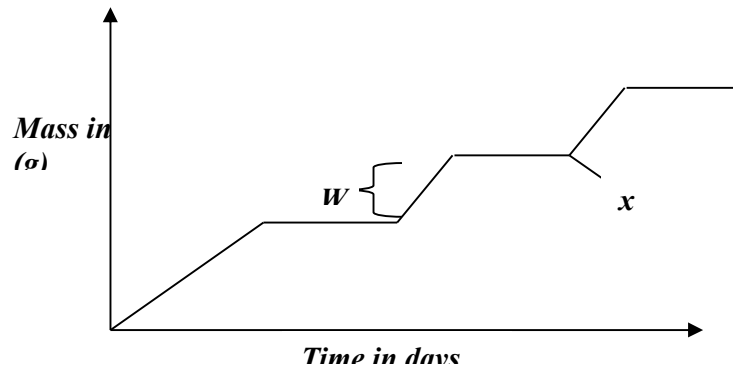

- (a) Name the type of growth pattern shown on the graph.
 (b) Identify the process represents by **x**.
 (c) Name the hormone responsible for the process in B above.
21. (a) State the role of the vascular cambium in plant growth and development.
 (b) Explain why monocotyledons plants do not undergo secondary thickening.
22. Explain how placenta is adapted to its functions
23. State the role of the following during germination:
 (a) oxygen
 (b) enzyme
24. Name the type of responses exhibited by:-
 (a) (i) Marine crabs burrowing into the sand to avoid dilution of their body fluids
 (ii) Chlamydomonas plant moving towards a region of high light intensity
 (b) (i) What type of neuron is drawn above?
 (ii) Using an arrow, show the direction of the nerve impulse
 (iii) Name the part labelled **X**
 (iv) State the function of part labelled **Y** .
 (c) Give **two** differences between reflex action and conditioned reflex action
25. The experiment set – up below was designed to investigate an aspect of germination.

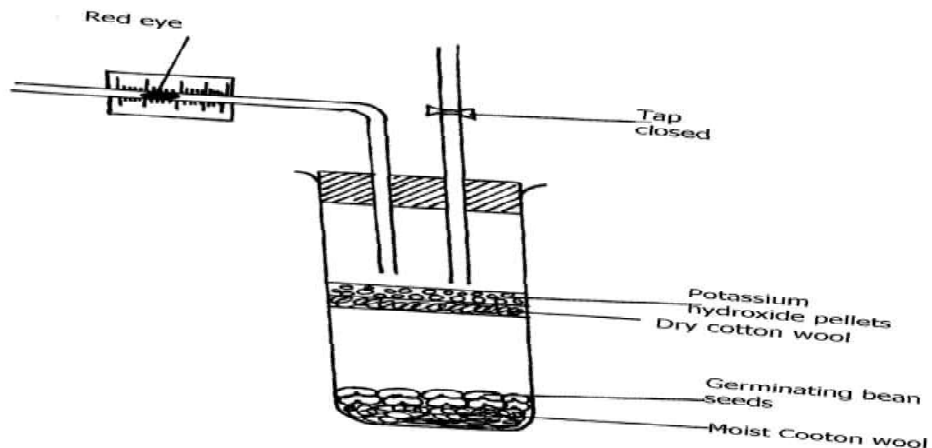

- a) Why was potassium hydroxide pellets used in this experiment?
- b) What was the role of moist cotton wool in this experiment?
- c) i) By means of an arrow, indicate on the diagram the direction in which red dye would move during the experiment.
ii) Give reason for your answer in c(i) above.
- d) Other than the factor investigated above, state any other **one** factor necessary for germination process.

26. The following data represents the development in dry mass of germinating seedlings within 18 weeks:

Time in weeks	0	1	2	4	6	10	13	15	16	18
Dry mass in grammes	0.1	2	3.2	10	18	32	44	45	44	38

- (a) Using suitable scales plot a graph of dry mass against time
 - (b) Write reference to the graph, explain the changes in dry mass between:-
 - (i) Week 0 to 2
 - (ii) Week 5 to 13
 - (iii) Week 16 - 18
 - (c) (i) What is the significance of time zero?
(ii) What difference would be expected from the above results if the experiment started with the seeds? Give a reason for your answer
 - (d) (i) Describe how you carry out the experiment to obtain dry mass in the respective weeks
(ii) State **one** advantage of using dry mass instead of fresh weight in estimating growth of an organism
27. The diagram below represents a set-up that was used to investigate the effect of rotation on the growth of a bean radicle. The set-up allowed the seedling to rotate slowly and continuously for seven days

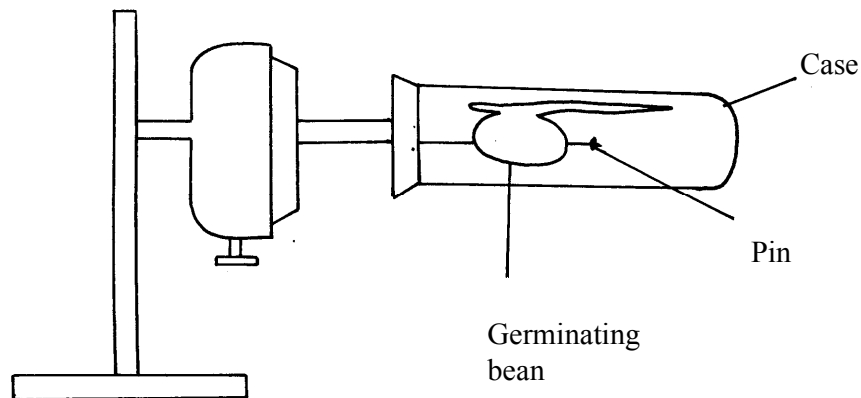

- (a) Name the piece of apparatus illustrated
- (b) (i) State the observation made on the shape of the radicle after seven days
(ii) Explain the observation in **(b) (i)** above
- (c) Suggest a suitable control for this experiment
- (d) Give any **four** importance of tropism in plants

28. An experiment was carried out to determine the growth rates of variety of bamboo and a variety of maize in two adjacent plots. The average height and average dry weight of plants from the two populations were determined over a period of twenty weeks. The data is as shown below:-
- On the same axes, plot a graph to show the changes in average weight of the bamboo and maize plants over time
 - (i) Which of the two plants had a higher productivity by the end of the experiment?
(ii) Give a reason for your answer in **(b)(i)** above
 - Explain the following:
 - Between weeks 14 and 18 the average height of maize plants remained constant while the average dry weight increased
 - Dry weight was used instead of fresh weight in this experiment
 - Describe how the average height and average dry weight of plants were determined in this experiment;
 - Why was it appropriate in this experiment to use both weight and height?
 - Give a reason why secondary thickening does not occur in bamboo and maize plants
29. (a) What is meant by the term **fertilization** ?
- (i) Name the type of cell division that produces gametes
(ii) Where does the type of cell division mentioned above occur in mammals?
 - What happens to the wall of the uterus;
 - before the release of an egg ?
 - if no fertilization occurs?
 - How is the placenta adapted to its functions?
30. The relationship between seed fresh mass in the lupin *lupinus* and percentage seed germination, percentage seedling survival and seedling fresh mass is shown in the table;

Seed fresh Mass mg ⁻¹	Percentage germination	Percentage of seedlings surviving 2 leaf stage	Mean seedling fresh mass 5 weeks after germination/mg
Below 16	41.9	84.6	24.3
17-25	90.2	96.8	44.2
26-35	95.6	98.8	60.7
36-45	97.5	100.0	86.4
Above 45	100.0	100.0	106.4

- How was percentage germination in column two of the table calculated?
 - Why was seed fresh mass preferred to seed dry mass to take measurements of the seed weight in the experiment
 - i) Explain why the measurements of mean seedling fresh mass (5) weeks after germinated may not have been an accurate measurement of growth that had occurred
ii) How could more meaningful and accurate measurement been obtained in **c(i)** above?
 - With reference to the figures in the table indicate the relationship between seed fresh mass and percentage seed germination, percentage seedling survival and seedling fresh mass
 - Suggest an explanation why seedling produced from large seeds grow more rapidly than the seedling produced from small seeds
31. The diagram below illustrate enzyme controlled reaction

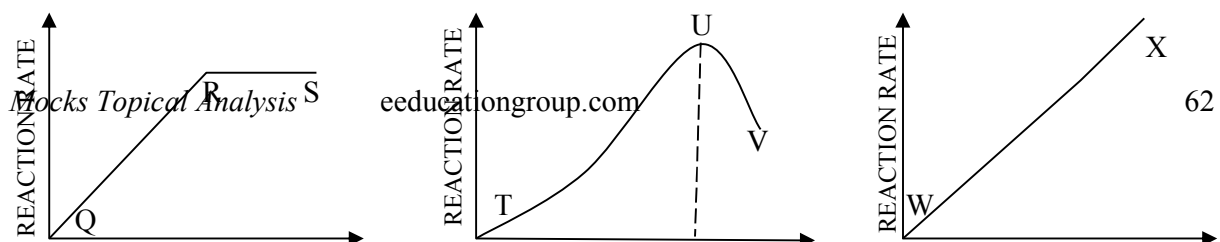

- a) State the relationship between rate of reaction and enzyme concentration
 b) Account for the rate of reactions between; i) Q and R
 ii) R and S
 iii) U and V
 c) Name **one** other factor that affects enzyme action, not illustrated above
32. Carefully study the figure below and answer the questions that follow:-

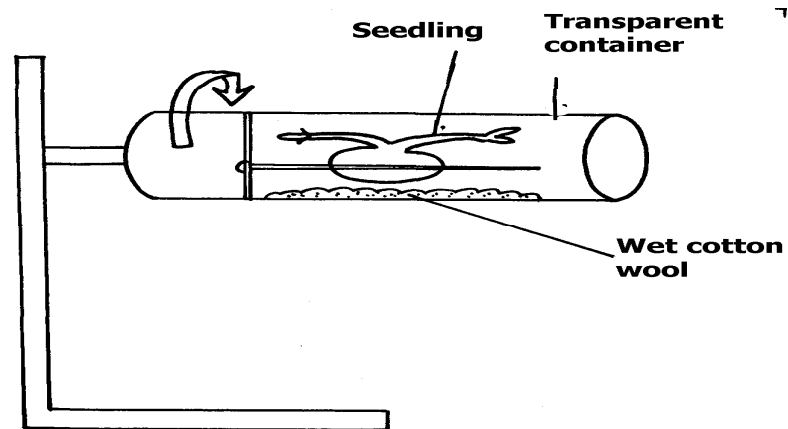

- The seedling with straight radicle and plumule was attached to a machine horizontally as shown above. The machine rotates making one revolution in 15 minutes.
- (a) Draw how the seedling would look like after one week
 (b) Explain your drawing in (a) above
 (c) Name the machine used in the experiment above
 (d) What would happen if the seedling was put horizontally outside the machine
 (e) Name the stimuli investigated and type(s) of response expected in the experiment
33. (a) Give the form in which each of the following substances are transported in mammalian blood:
 (i) Carbon (IV) oxide
 (ii) Oxygen
 (b) Give **two** functions of pleural membrane
 (c) Explain why formation of carboxyhaemoglobin in the blood of a mammal results in death
 (d) Other than stomata, name **two** other gaseous exchange surfaces in plants
34. In an experiment the radicle of a seedling was marked equidistant using Indian ink as shown

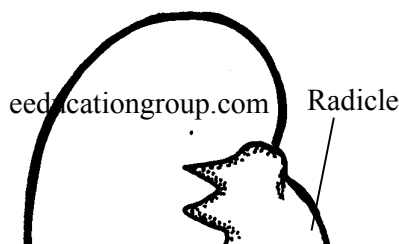

- (a) What was the aim of the experiment?
(b) On the diagram below mark on the radicle to show the appearance of the marks after 3 days

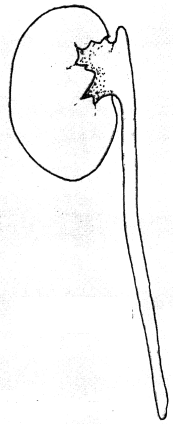

- (c) State **three** characteristics of cells found just behind the root cap of a radicle
(d) Give **two** factors inside a seed that causes seed dormancy

12. Genetics

1. A woman with blood group **A** gave birth to twins both having blood group **AB**.
Determine the genotype of:
a) Father
b) Mother
2. 50 black mice and 50 white mice were released into an area inhabited by a pair of owls. After four months, the mice in the area were recaptured and only 38 of the black mice and 9 of the white mice were remaining.
a) How would this observation be explained ?
b) Name the theory of evolution that supports the results in (a) above.

3. State **three** mechanisms that prevent self pollination in a flower that has both male and female Parts.
4. (a) Distinguish between complete and incomplete dominance
(b) State **two** sources of variation
5. Part of one strand of a DNA molecule was found to have the following base sequence.

G - T - C - A - G - T

(a) What is the sequence on m-RNA strand copied from this DNA portion?
(b) State **two** roles of DNA molecule.
6. State **three** ways by which plants compensate for lack of ability to move from one place to another.
7. A student mixed a sample of urine from a person with Benedict's solution and heated, the colour changed to orange.
(a) What was present in the urine sample?
(b) What did the student conclude on the health status of the person?
(c) Which organ in the person may not be functioning properly?
8. Differentiate between continuous and discontinuous variations
9. Members of the same species of organism tend to differ due to variation. State **three** causes of variation in organisms
10. Identify the type of gene mutations represented by the following pairs of words:-
(i) Shirt instead of skirt
(ii) Hopping instead of shopping
(iii) Eat instead of tea
11. A DNA stand has the following base sequence: GCCTAGATCAC
What is the sequence of the : (i) Complementary DNA strand?
(ii) M-RNA strand copied form this DNA strand
12. The figure below represents the distribution of height of pupils in a school

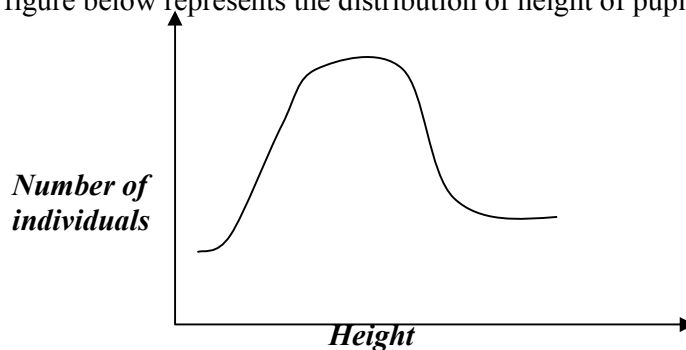

- (a) Name the type of variation represented by the curve
- (b) Outline **two** possible causes of variation in height of individuals in man
13. a) Wekesa and Wanjiku who are siblings are both normal as their parents but have a hemophilic brother. Give the Genotype of their parents.
b) i) What are linked genes?
ii) What do you understand by the phase a test cross?
14. There are at least 205 known sex – linked recessive disorder
a) Name **any two** of them.
b) State a reason why sex – linked recessive why traits tend to effect the male child.

- c) State why if a mother has the trait all her sons will have it
15. The table below is a representation of a chromatide with genes along its length. It undergoes mutation to appear as shown below:

Before mutation	L	M	N	O	P	Q
After mutation	L	O	N	M	P	Q

- a) Name the type of chromosomal mutation represented
- b) Name **one** mutagenic agent
16. The figure below is a structural diagram of a portion from a nucleic acid strand
- a) Giving a reason, name the nucleic acid to which the portion belongs
- b) Write down the sequence of bases of a complementary DNA strand
17. In an experiment, plants with red flowers was crossed with plants with white flowers.
- All the plants in the **F₁** generation had pink flowers.
- a) Give a reason for the appearance of pink flowers in the **F₁** generation
- b) If plants in **F₁** were selfed, state the phenotypic ratio of the **F₂** generation
- c) Explain; i) Why women should drink extra milk during pregnancy
 ii) A pregnant women might want to urinate more often in late pregnancy
18. State the meaning of the following terms giving an example in each case:
- (a) Sex-linked genes
- (b) Multiple alleles
19. In a certain breeding experiment, a plant species with red flowers was selfed. It produced **119 red** flowered and **41 white** flowered offsprings.
- (a) Using letter **R** to represent allele for the red flowers, state the genotype of the red flowered parent plant
- (b) Determine the phenotypic ratio of red and white flowered plants. Show your working
20. Give an example of a sex-linked trait in human on:
- (i) **Y** – Chromosome
- (ii) **X** – Chromosome
21. Explain why growth of long hair on the pinnae of the ears in human occurs in males only
22. Explain why **prophase 1** of meiosis contributes towards genetic variation in living organisms.
23. A pure Red flowered plant was crossed with a pure white flowered plant. All the **F₁** generation plants had pink flowers.
- (a) Give an explanation for the absence of Red and white flowered plants in the **F₁** generation.
- (b) If the **F₁** generation pea plants were selfed, state the phenotypic ratio of the **F₂** generation plants.
24. (a) Name a genetic disorder due to gene mutation that affects the malpighian layer of the skin in man.
- (b) Give **two** functions of the fluid produced by sebaceous glands.
25. (a) Define the term “Gene mutation.”
- (b) Name the genetic disorders that result from gene mutation in human beings.
26. (i) What are mutations

- (ii) Name **two** mutagens
27. A section of a DNA strand contains the following sequence CGGATAC
- (a) Write the; (i) Complementary DNA strand
(ii) mRNA strand
- (b) Name the site for protein synthesis in a cell
28. In a certain bird species, red flight feathers is controlled by gene **R** while white flight feathers is controlled by gene **r**. The heterozygous condition **Rr** results into pink flight feathers. The two genes are also sex linked and transmitted on x-chromosome.
- a) By use of fusion lines, find the genotypes of across between a male with pink flight feathers and a female with white flight feathers
- b) Which type of dominance is illustrated here?
- c) i) Identify the nucleic acid whose base sequence is shown below:
G-A-C-U-A-G-A-C-G
ii) Give a reason for your answer in **c (i)** above
iii) If the nucleic acid was involved in protein synthesis, how many amino acids would be present in the protein synthesized? Give a reason

29. Study the genetic chart below showing the inheritance of the gene responsible for haemophilia in a family.

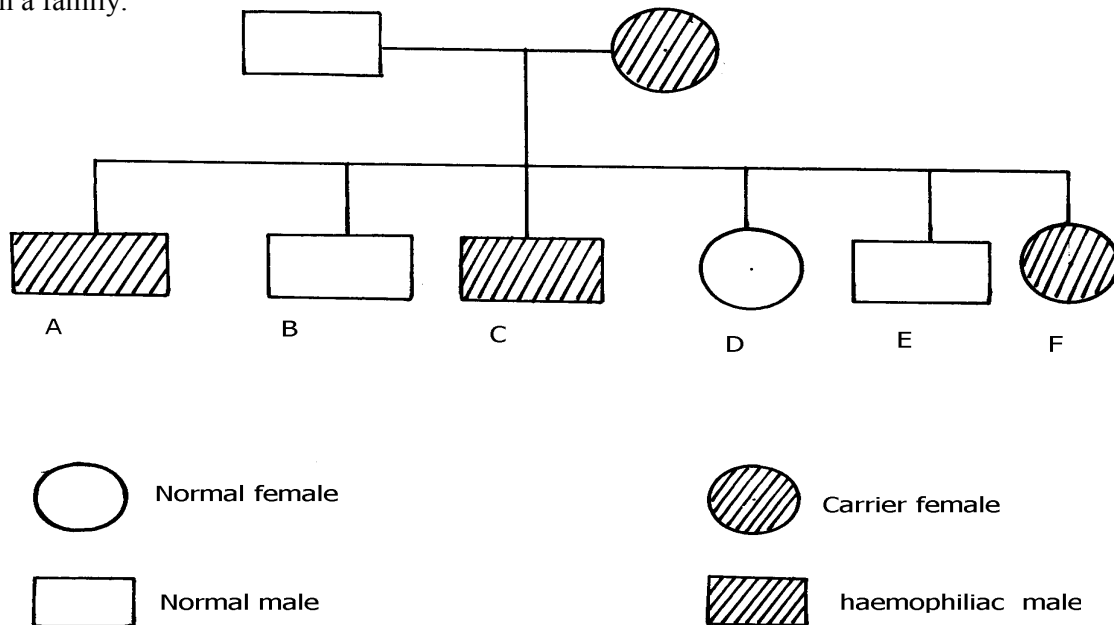

- a) Write the genotype of individuals A, B, F
- b) A member of this family labelled **F** marries a haemophiliac male. What will be the phenotypic ratio of the offspring? Show your workings
- c) Other than the condition stated above, state any other **two** common genetic disorders that result from gene mutation.
30. Haemophilia is due to a recessive gene. The gene is sex-linked and located on **X** chromosome. The chart below represents the offspring of parents who are phenotypically normal for

t

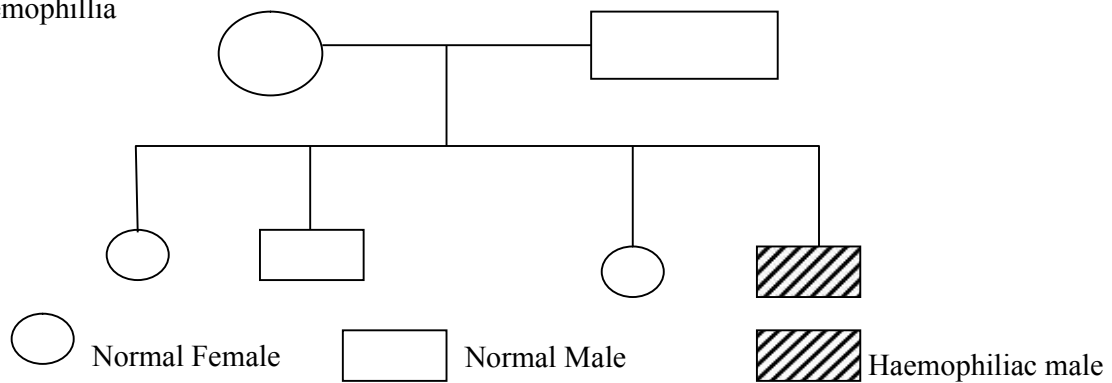

- (i) What are the parental genotypes?
Explain your answer in (i) above
- (ii) Work out the genotypes of the offspring
31. A cross between a red-flowered and a white flowered plant produced only pink –flowered F_1 plants
- (a) There was neither a red nor white –flowered F_1 plants. Explain
- (b) The F_1 offspring were selfed to get F_2 generation. Using appropriate letter symbols, work out the genotypes of F_2 generation
- (c) Give the genotypic and phenotypic ratios of F_2 generation
- (d) Distinguish between dominant and recessive genes
32. A true-breeding purple maize variety was cross-pollinated with a true-breeding yellow maize variety.

The offspring produced all purple fruits.
The plants grown from these F_1 grains were interbred among each other.
A typical cob of F_2 generation is shown below:
The yellow fruits are shaded while the purple ones are un-shaded.

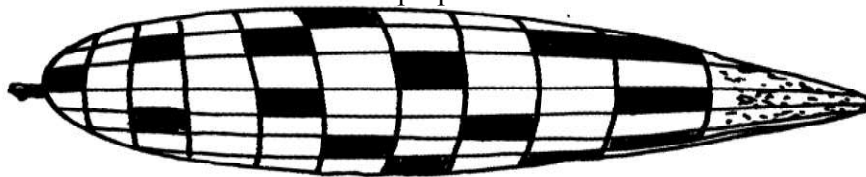

- (a) (i) In terms of flowers only, state why it is easier to work out genetic crossings using maize
(ii) Count separately the yellow and purple grains and therefore find the ratios of purple grains to yellow grains
- (b) Using appropriate symbol, work out a genetic cross for F_2 generation
- (c) From the above information, give the dominant gene
- (d) State **two** practical applications of genetics in identity determination
33. The figure below is a pedigree chart showing incidence of albinism which is transmitted through a recessive gene-a. Study and answer questions that follow;

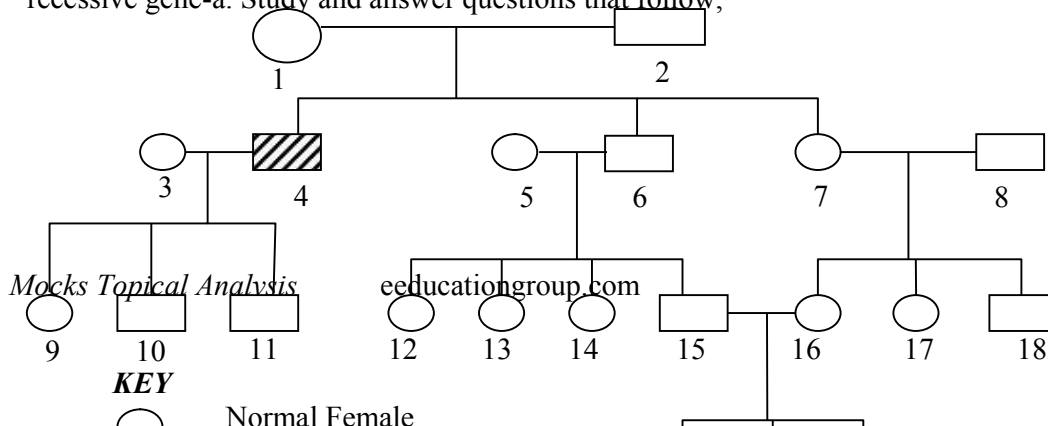

Mocks Topical Analysis

educationgroup.com

KEY

Normal Female

- (a) Write down the genotype of persons 1 and 2. Give a reason for your answer
 (b) Giving your reason state the most likely genotype of person 3
 (c) The cross between person **15** and **16** represents mating between first cousins. Comment why it is not advisable for close relatives to marry
 (d) Apart from albinism name **two** other effects of gene mutation
34. The table below shows results of test to determine blood groups of persons **Y** and **Z**. A tick (✓) Represents, agglutination while a cross (x) represents no agglutination;

Person	Test with antibody (a)	Test with antibody (b)	Test with Rhesus antibody	Blood group
Y- (male)	✓	X	✓	
X- (female)	X	✓	X	

- (a) Fill the blank space in table to show the blood group of the persons **Y** and **Z**
 (b) In order to investigate the inheritance of Rhesus factor, work out a cross between a male with Rh^+ and female with Rh^- . Let **D** represent the presence of Rhesus factor and **d** to represent the absence of the Rhesus factor
 (c) Determine the genotype of the cross in (b) above.
 (d) Which of the children can donate blood to their mother?
35. Describe the behavioural adaptations of animals to temperature
36. In man blood group inheritance is controlled by multiple alleles in which allele **A** is co dominant to allele **B**. a woman laterozygous for blood group **A** married a man heterozygous for blood group **B**
- a) State the genotype of both parents
 b) Using a pun net square, show the genotypes of F_1 generation
 c) State **one** application of knowledge of blood group inheritance in man
 d) The nitrogenous bases in nucleic acids are Adenine (A), cytosine(C), Guanine (G), Thiamine (T) and uracil (U). Input of a molecule of DNA the sequence of bases is CTT. Using the letters **A, C, G, T, U** where appropriate, write down the base sequence in;
 i) Corresponding part of the complementary strand of DNA molecules
 ii) Corresponding part in mRNA

- iii) A change in the DNA molecules caused the base sequence in the triplets to change from CTT to CAT. State **one** factor which could have caused the change
37. In an investigation plants with red flowers were crossed with plants with white flowers. All the plants in the F₁ generation had pink flowers when the F₁ plants were crossed, he counted 480 plants in F₂ generation
- (a) Using appropriate letter symbols, work out the cross between the F₁ plants to get the F₂ generation
- (b) Give the phenotypic and genotypic ratios for the F₂ generation
Phenotypic ratio
Genotypic ratio
- (c) How many plants in the F₂ generation had pink flowers? (show your work)
38. In an experiment, a black mouse was mated with a brown mouse. All the off springs in F₁ generation were black. The off springs grew and were allowed to mate with one another. The total number of F₂ generation offspring were 96.
- (a) Using letter **B** to denote the gene for black colour. Work out the genotype of the F₁ generation. (Use a punnet square)
- (b) State the following for the F₂ generation
- (i) Genotypic ratio
- (ii) Phenotypic ratio
- (iii) The total number of brown mice
39. (a) Distinguish between Homologous structures and analogous structures. Give an example in each case.
Homologous structures
Example
Analogous structures
Example
- (b) Explain why parasites develop resistance to certain drugs after a long time of exposure.
- (c) (i) What is non— disjunction?
(ii) Give **one** example of a genetic disorder associated with non-disjunction .

13. Evolution

1. a) Distinguish between homologous and analogous structures in evolution.
b) Name **one** vestigial structure in mammals.
2. a) Give **two** examples of adaptive radiation in animals.
b) State **two** disadvantages of using fossils as evidence of evolution
3. Distinguish between camouflage and mimicry.
4. State the role of light in photosynthesis
5. (a) Name the region of the **gut** where digestion of cellulose takes place.
(b) State role of **cardiac sphincter** in the stomach.
6. (a) Give **two** limitations of fossil records as evidence of evolution
(b) State any **two** similarities in structure between **Homo erectus** and **Homo Sapiens**
7. (a) (i) What is meant by vestigial structures?

- (ii) Give an example of a vestigial structure in human
8. Distinguish between the struggle for existence and survival for the fittest as used in the theory of natural selection
 9. Give **two** factors that determine water reabsorption in the distal convoluted tubule
 10. Distinguish divergent and convergent evolution
 11. (a) What are the advantages of natural selection
(b) All insects are believed to have arisen from a common ancestor. However, modern insects differ widely in a variety of ways such as in the adaptation of their mouthparts for different modes of feeding. What kind of evolution is this?
 12. Explain why Lamarck's theory of evolution is not accepted by Biologists today.
 13. a) i) What is meant by vestigial structures
ii) Give an example of vestigial structure in human
b) Explain why certain drugs become ineffective in curing a disease after many years of use
 14. (a) What is organic evolution?
(b) Briefly explain the term "*survival for the fittest*" as used in Darwin's theory of natural selection
 15. Explain why insecticides become ineffective against insects if used for several years in succession
 16. State **three** limitations of fossils records as an evidence of organic evolution
 17. State **three** pieces of evidence that support the theory of organic evolution
 18. What is meant by natural selection?
 19. (a) Explain why Lamarck's theory of evolution is not accepted today
(b) State **two** limitations of fossils records as evidence of organic evolution
 20. In a breeding experiment, plants with red flowers were crossed. They produced 123 plants with red flowers and 41 with white flowers:
 - (a) Identify the recessive trait
 - (b) Give a reason for your answer
 - (c) If white flowered plants were selfed, what would be the genotype of their offspring?
Show your working using appropriate symbols (**R**, **r**)
 - (d) What is a test cross?
 21. a) What is organic evolution?
b) Describe the various evidences which support the theory of organic evolution.
 22. (a) What is meant by the term natural selection
(b) Describe how natural selection brings about the adaptations of a species to its environment
(c) Distinguish between convergent and divergent evolution
(d) Discuss **four** evidences to show that evolution has taken place
 23. Explain the various evidence for organic evolution
 24. (a) What is organic evolution
(b) Explain why resistance to antibiotics is considered as an example of evolution
(c) List and explain various evidences of organic evolution
 25. Pure breed red flowered plants were cross pollinated with pure breed white flowered plants.
The resulting F₁ offspring's had pink flowers.
 - (a) Using letter **R** to represent the gene for red colour and letter **W** to represent gene for white colour of flowers. Work out the genotype of the **F₁** generation

- (b) If seeds from the F_1 generation plants were planted and allowed to self pollinate. Work out the phenotypic ratio of the F_2 generation

14. Irritability and sensitivity in (a) plants (b) animals

1. Give **two** functions of the exoskeleton in arthropods.
2. When shoots of young plants are exposed to unidirectional light they bend towards light;
 - a) Name the type of response exhibited by the young shoots
 - b) Explain the cause of the observation above
3. Study the drawing below and use it to answer the questions that follow :-

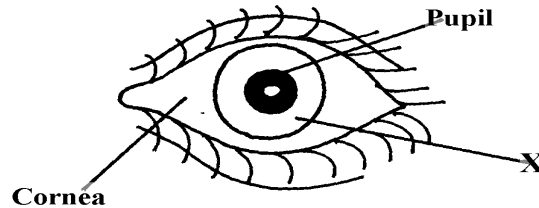

- a) Name the part labeled **X**.
- b) Describe the changes that occur in the structure **X** in dim light.
- c) What is meant by the term **accommodation** with reference to the eye?
4. (a) State **two** differences between taxes and tropisms
- (b) Give **two** survival values of tactic movements to organisms
5. The diagram below represents a type of neurone.

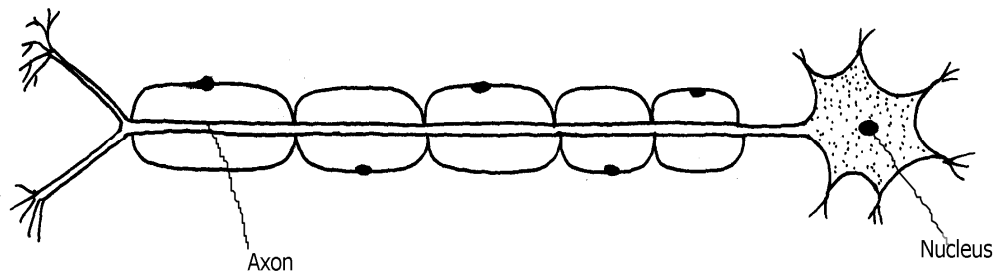

- (a) (i) identify the neuron above.
- (ii) Give a reason for your answer in a (i) above.
- (b) With an arrow, indicate on the diagram the direction of an impulse through the neurone.
- (c) Name the chemical substance that brings about transmission of impulse across a synapse
6. A student was traveling from Nairobi to Mombasa. As the bus descended down hill he felt an unpleasant sensation in the ear.
- (a) How did the sensation come about? *
- (b) How can the unpleasant sensation be relieved?

7. An experiment was carried out to investigate a growth response in maize seedling as shown in the diagram below:

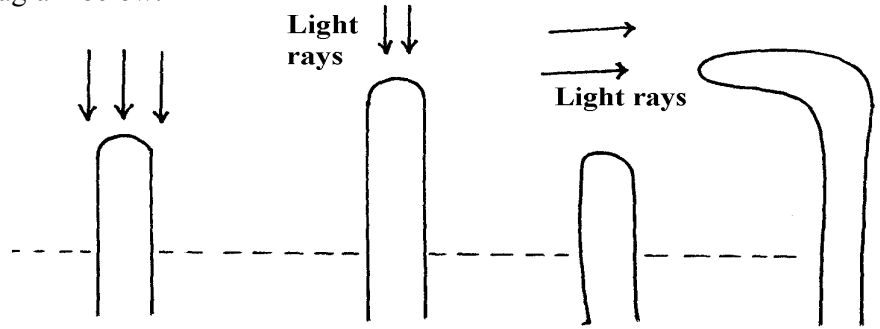

- (a) State the type of response that is being investigated
 (b) Explain the response exhibited by the shoot
8. State **three** genetic disorders caused by gene mutations
9. The diagram below shows the position of an image formed in a defective eye:-

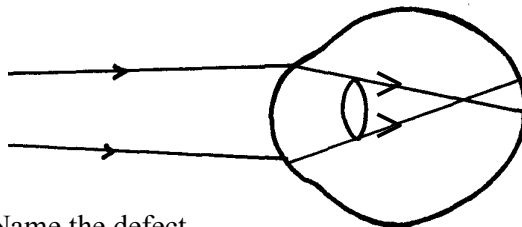

- (a) Name the defect
 (b) Explain how the defect named in (a) above can be corrected
10. (a) State **three** structural differences between arteries and veins in mammals
 (b) Name a disease that causes thickening and hardening of arteries
11. (a) Name the part of the eye in which the light sensitive cells are located
 (b) List the **two** types of sensory cells found in the part named in (a) above
12. The diagram below illustrates a certain eye defect

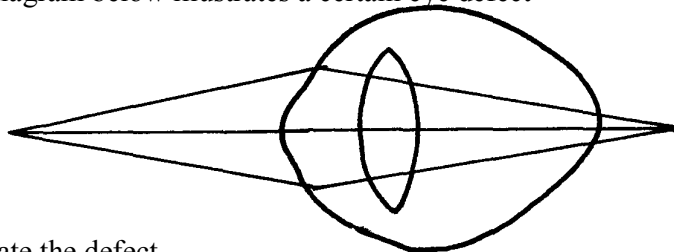

- (a) State the defect
 (b) On the diagram illustrate how the defect can be corrected
 (c) State **one** advantage of having two eyes in human beings
13. Briefly explain the role of the following part of skin
- a) Cornified layer
 b) Malpighian layer
14. State the functions of the following structures of the mammalian ear
- a) Eustachian tube
 b) Essicles
15. a) Distinguish between conditioned and simple reflexes
 b) State how the nerve cell structure is suited to its function of impulse transmission
16. (a) Name the part of the mammalian eye that:

- (i) Transmits impulses to the brain
 - (ii) Regulates the amount of light entering the eye
- (b) State the changes that occur in the part of the eye named in (a) (ii) above when one moved from bright light to dim light conditions
16. Name the type of response exhibited by the following:
- (a) A pollen tube growing towards the embryo sac
 - (b) Maggots moving from lit side of a box to the dark side
17. A response exhibited by a certain plant tendril is illustrated below:

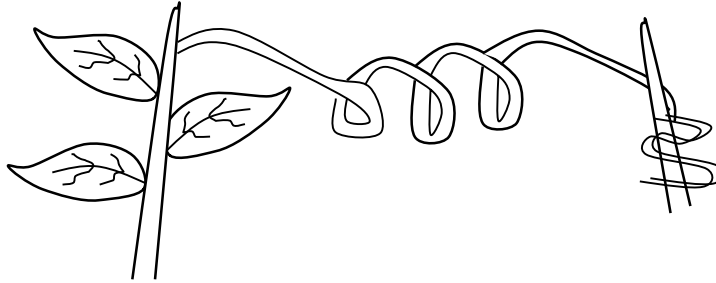

- (i) Name the type of response
 - (ii) Explain how the response named in (i) above occurs
18. A response exhibited by a certain plant tendril is illustrated below:-

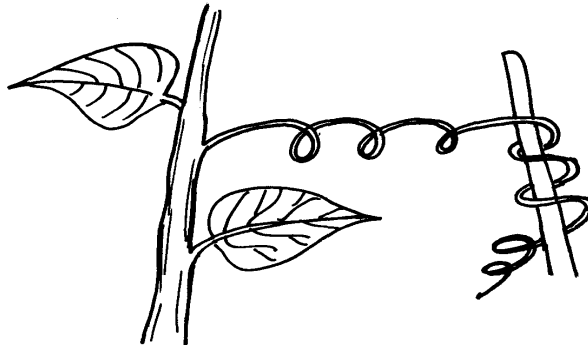

- Name the type of response
19. Removal of the apical bud from a shrub is a practice that results in the development of many lateral buds which later form branches
- (a) Give reasons for the development of lateral branches after the removal of the apical bud
 - (b) Suggest **one** application of this practice?
20. In an accident a victim suffered brain injury. Consequently he had loss of memory which part of the brain was damaged?
21. A person was able to read a book clearly at arm's length but not at normal reading distance
- (a) State the eye defect the person suffered from
 - (b) Why was he unable to read the book clearly at normal distance?
 - (c) How can the defect be corrected?

22. The diagram below represents a simple reflex arc;

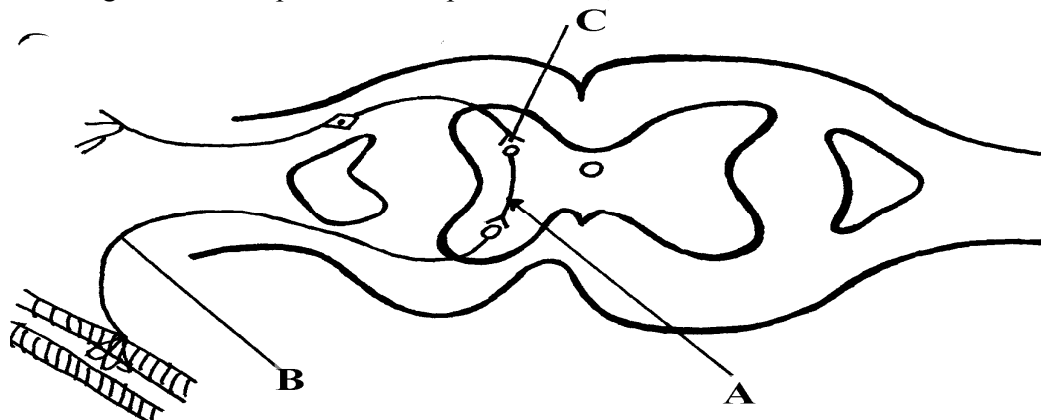

- (a) Name the parts labeled **A** and **B**
 - (b) Explain how an impulse is transmitted across the gap labeled **C**
23. (a) State **two** functions of a mammalian ear
- (b) How is the cochlea suited to its function
24. State **one** function of potassium ions in the human body.
25. State **two** functions of vitamin B₅ (pantothenic acid).
26. (a) What is the biological importance of tactic responses?
- (b) A person had an accident and had problems with his vision, hearing and memory. Identify the part of the brain that was affected
27. Identify the following responses shown by plants:- (a) Shoots grow towards light
- (b) Roots grow towards gravity
- (c) Tendril intertwine around an object
28. Name the type of responses exhibited by:-
- (a) (i) Marine crabs burrowing into the sand to avoid dilution of their body fluids
 - (ii) Chlamydomonas plant moving towards a region of high light intensity
 - (b) (i) What type of neuron is drawn above?
 - (ii) Using an arrow, show the direction of the nerve impulse
 - (iii) Name the part labelled **X**
 - (iv) State the function of part labelled **Y**
 - (c) Give **two** differences between reflex action and conditioned reflex action
29. In an experiment to investigate the effect of heat on germination of seeds, 12 bags each

Containing 60 pea seeds were placed in a water bath maintained at 85°C .

After every two minutes a bag was removed and seeds contained in it planted. The number that germinated was recorded. The procedure used for pea seeds was repeated for wattle seeds. The results were as shown in the table below:-

Time (min)	Number of seeds that germinated	
	Pea seeds	Wattle seed
0	60	0
2	60	0
4	48	0
6	42	2
8	34	28
10	10	36
12	2	40

14	0	44
16	0	46
18	0	48
20	0	49
22	0	47

- (a) Using a suitable scale and same axes, draw graphs of number of seeds that germinated against time in hot water for each plant
- (b) (i) At what time would number of seeds that germinated for each plant be same?
 (ii) How many wattle seeds would have germinated if the 13th bag was available and was removed and seeds contained in it planted at 24 minutes?
- (c) Explain why the ability of pea seeds that germinated declined with time of exposure to heat
- (d) Explain why the ability of the wattle seeds to germinate improved with time of exposure to heat
- (e) Account for the shape of the graph for the wattle seeds which germinated between 20-24 minutes
- (f) Some of the pea seeds were allowed to germinate and placed in a large air tight flask and left for four days:-
 (i) Suggest the expected changes in the composition of gases in the flask on the fifth day
 (ii) Give reasons for your answer **in (f)(i)** above
- (g) Name **three** factors other than those investigated in **(a)** above which would affect dormancy
30. How is the mammalian skin adapted to its functions?
31. Explain how the mammalian skin is adapted to its functions
32. Explain the structure and functions of the human eye.
33. The diagram below shows the position of an image in a defective eye.

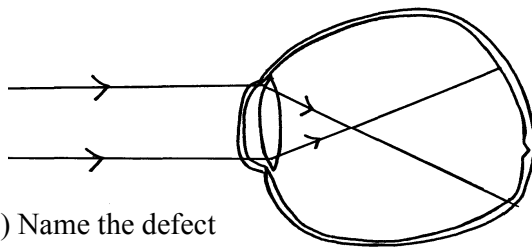

- (a) (i) Name the defect
 (ii) State the causes of the defect
- (b) Explain how the defect in **a(i)** above can be corrected.
- (c) State the functions of cones
- (d) How are nocturnal animals adapted to seeing?

5. Support and movement in (a) Plants (b) animals

1. Explain how the following tissues are adapted to provide mechanical support in plants:-
 a) Parenchyma
 b) Collenchyma
 c) Sclerenchyma
2. The diagram below represents a bone in the mammalian skeleton

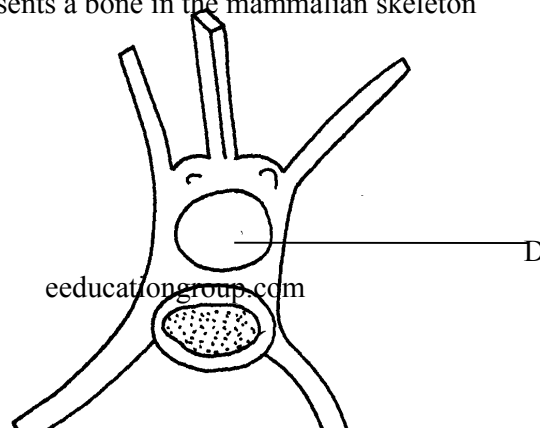

- a) Identify the bone with a reason
 b) State the function of the part labeled **D**
3. The diagram below represents a mammalian bone

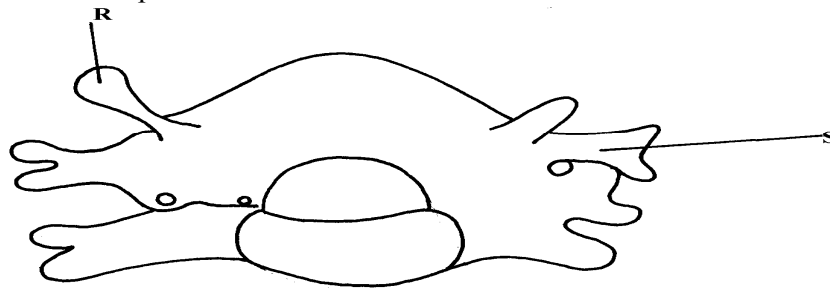

- (a) Identify the bone shown above
 (b) State the function of the parts labelled **R** and **S**
 (c) State the region of the body in which the bone is found
4. (i) Name **two** bones that form the ball and socket joint in the fore limb of a mammal
 (ii) Name the fluid that is found in the above mentioned joint and its function
5. State **three** types of skeleton found in Kingdom animalia
6. State **three** differences between an animal's muscle cell and plant's palisade cell
7. The diagram below represents a mammalian bone

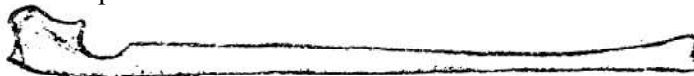

- (a) Name the bone
 (b) (i) Which bone articulates with the bone shown in the diagram at the notch
 (ii) Name the type of joint formed when the bones in **(i)** articulate
8. (a) Name the hard outer covering of the members of the phylum Arthropoda
 (b) State **two** roles played by the structure named in **(a)** above
9. (a) State the role of lignin in the wall of the xylem vessel
 (b) How does vascular bundles contribute to support in plants
10. (a) Distinguish between tendons and ligaments
 (b) State **one** way through which herbaceous plants achieve support
11. Name the ;
- a) i) Material used to strengthen the xylem tissue
 ii) Tissue that is removed when the bark of a dicotyledonous plant is ringed
 b) State the areas of the plant where translocated materials are taken
12. Give **three** importance of mammalian skeleton
13. The diagram below represents the anterior view of a rib

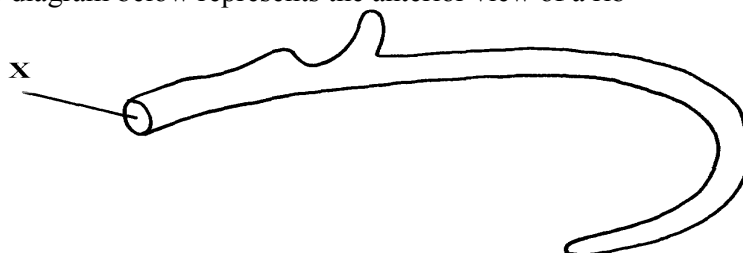

Name the part labelled X

14. The diagram below represents a bone obtained from a mammal

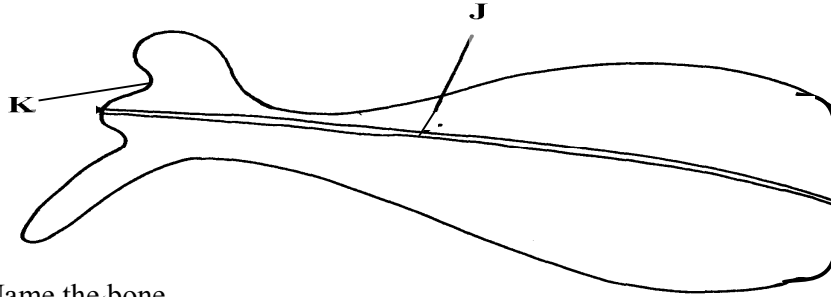

- a) Name the bone
 b) Name the:
 i) Bones which articulate with the bone named in (a) above at the cavity labelled K
 ii) Joint formed by the two bones at K
 c) State functions of part labelled J
15. The diagram below represents a bone obtained from a mammalian skeleton:

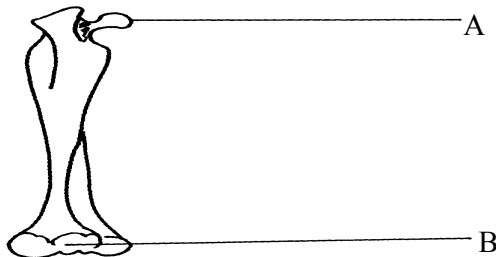

- (a) Identify the bone
 (b) Name the:
 (i) Bone it articulates with at point A
 (ii) Type of joint that forms at point B in articulation with other bones
16. The diagram below represents a bone obtained from a mammal

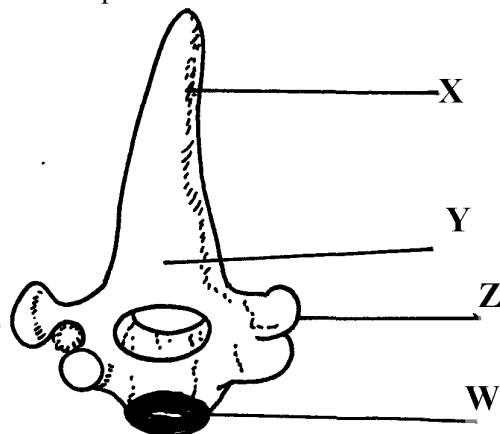

- (a) Identify the bone
 (b) Name the structures labeled X and W
 (c) Name the bone that articulate with structure labeled Z

17. (a) Name the vertebra in a mammalian body that is characterised by presence of **odontoid process**.
 (b) State the function of the **odontoid process**
18. a) Name **three** supporting tissues in plants
 b) Study the diagram below and answer the questions which follow:

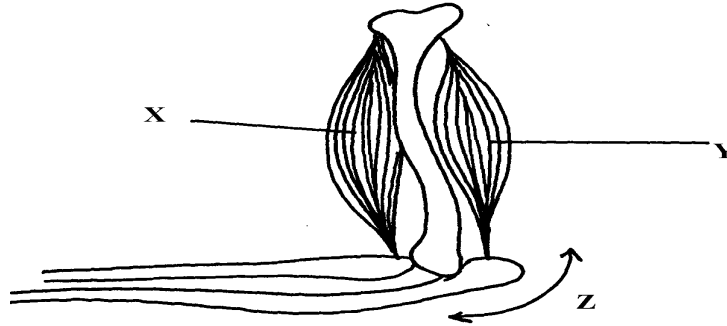

- i) Identify the muscle represented by X and Y
 ii) Describe how muscles x and y cause straightening of the joint z
 c) Name the joint z
19. (a) What is the importance of locomotion in animals?
 (b) Explain how a bony fish is adapted for movement in its habitat

16. Human health

1. a) Name the causative agent of cholera.
 b) Name the intermediate hosts in the life cycle of the following parasites;
 i) Ascaris lumbricoides.
 ii) Schistosoma haematobium.
 c) How does the parasite plasmodium vivax gain entry into its host?
2. The graph below shows body temperature of a patient suffering from malaria

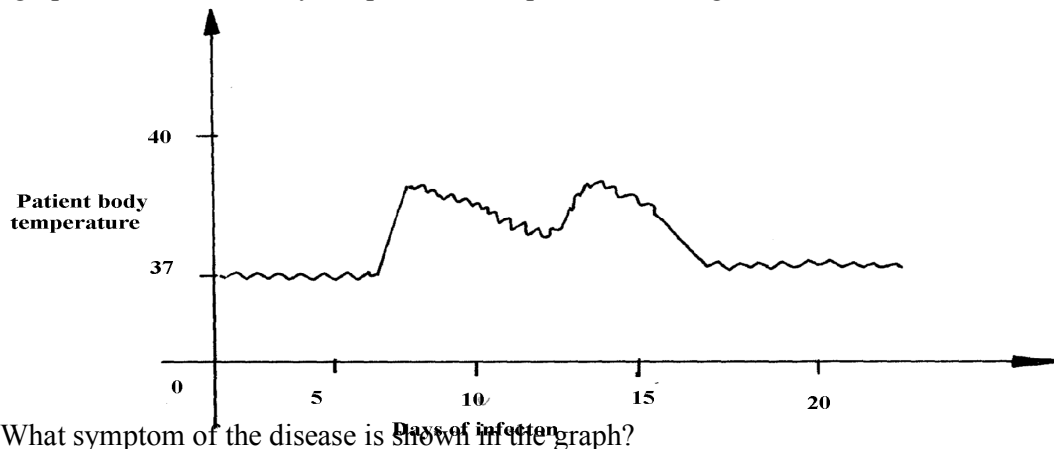

- (a) What symptom of the disease is shown in the graph?
 (b) Name the organism that causes malaria
 (c) Suggest **one** method of controlling spread of malaria
3. Name the causative agent of typhoid
4. Malaria is a common disease in Kenya:-
 (a) What causes the disease?
 (b) State **one** control measure of the disease
5. a) Name the causative agents of the following disease in humans:-
 i) **Typhoid**;

- ii) **Amoebic dysentery;**
b) Name the disease in human caused by plasmodium falciparum
6. Below are diagrams of disease causing micro-organisms. Use them to answer the questions that follow:

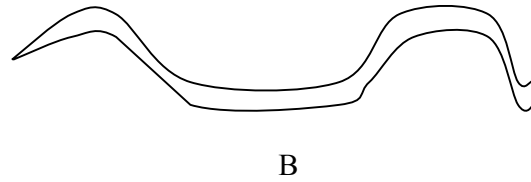
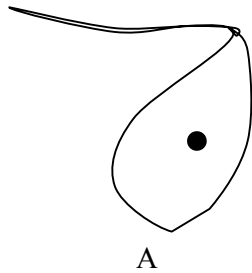

- (a) State the kingdom to which they are found.
(b) Name the diseases caused by the organisms: A and B
(c) State **one** way in which the disease named for organism B can be prevented
7. Explain why it is important to go for voluntary counseling and testing (VCT) on HIV/AIDS
8. Name **one** human disease caused by each of the following parasites.
(a) Plasmodium falciparum.....
(b) Entamoeba histolytica

SECTION I & II MARKING SCHEME

1. Classification I &II

1. arachnida; crustacean;
2. - Body is covered by fur or hair;
- Have mammary glands (for milk production);
- Have external earlobes;
- Have highly developed brain;
- Have muscular diaphragm that have sweat glands;
- Have muscular diaphragm (that thoracic cavity from abdominal cavity); (first three)
3. - Two names i.e first genus and second species;
- Genus names starts with capital letter while species starts with small letter;
- Both names are written in italics, when printed or underlined when types or handwritten;
4. (a) Kingdom Monera;
(b) Producing antibiotics; vaccines; hormones and in producing transgenic organisms in modern technology;
5. Chordata;
6. a) Fungi;
b) Sporulation;
7. Prothoracic glands disintegrates hence no production of ecdysone / moulting hormone
8. Zoology;
- Mushrooms used as food;

9.
 - penicilium are used to make antibiotic;
 - Yeast is used in brewing and bread baking;
10. Sub-division – Angiospermaphyta;
Class – Dicotyledonae;
11. arachnida;
12. (a) (i) Fungi/mycophyta:
(ii) Non— green/ lacks chlorophyll;
- Body made up of hyphae/ mycelia;
(b) (Asexual) reproduction: OW WTE
13. (a) taxonomy is the classification of living organisms on their similarities and difference observed
(b) (i) Rottus norvegicus (1mk) (Genus name MUST begin with capital letter and be underlined separately)
(ii) Genus – Rattus;
Species – norvegicus;
14.
 - A segmented body;
 - A hard exoskeleton;
 - Jointed legs;

2. The cell – structure & functions of organelles

1.
 - a) Lysosomes;
 - b) Contractile vacuoles;
2.
 - (a) Make cells visible;
 - (b) Prevent distortion of cells;
3. Diameter of field of view
= 4mm x 1000mm = 4000μm;
Size of each cell = $\frac{4000}{20}$
= 200μm;
4.
 - a) Manufacture of ribosomes;
 - b) encloses cell contents; regulate movement of materials in and out of the cell;
5. Protein:
Nucleic acid (DNA – RNA);
6. (i) Mg = O.L.M x E.L.M;
= 100 x 5
= x500;
(ii) x 500 = 5 x 10,000 = 50000mμ
x 1 = ?

$$= \frac{1 \times 50,000}{500}$$

= 100micrometer;

7. a) mitochondria;
b) -has cristae/inner membrane highly folded to increase surface area; for respiration.
-Has matrix medium for respiratory activities; (reject (b) if (a) is wrong.)
-Has matrix medium for respiratory activities; (reject (b) if (a) is wrong.)
8. a) nucleolus;
b) Centrioles;
c) nuclear membrane/pore;
9. a) catalyses the breakdown of toxic hydrogen peroxide; to harmless water and oxygen in active tissues;
b) Low temperature;
10. a) i) Nucleus.
ii) Formation of RNA / ribonucleic acid;
Formation of ribosomes;
b) i) Contractile vacuole;
ii) Lysosomes;
11. Sensitive to change in temp; sensitive to changes in PH; has both negative and positive charges;
12. a) Cellulose;
b) Store sugars, salt and food; carry out osmoregulation by inducing osmotic gradient that bring about water movement; maintain the shape of the cell;
c) Cell wall; and chloroplast;
13. Study of internal and external parts of the body of an organism; Study of the living organisms and their chemical composition;
14. a) Synthesis of proteins;
b) Site for photosynthesis;
15. a) Length of drawing :
Length of object
16. (a) Ribosomes:- Protein synthesis(1mk);
(b) Centrioles – Spindle formation during cell division ;
- Form cilia and flagella
17. (a) cellulose;
(b) Lipoproteins/lipids and proteins;
18. - No organized nucleus;
- Organelles not bound by membranes;
- Lack mitochondria;
19. (a) X : Chloplasts;

Y : Vacuole /sap vacuole;

- (b) More on the upper side to obtain optimum light intensity/ in bright light, they move away to avoid bleaching/ in dim light they move towards the source of light for maximum absorption of light;
20. Cell diameter = $\frac{\text{field of view in menometer}}{\text{Number of cells under the field of view}}$
$$\frac{3.5 \times 1000}{8} \quad ; \quad \frac{3500}{8}$$
$$= 437.6 \mu\text{m} = 438 \mu\text{m};$$
21. i) Arachnida
ii) - Exoskeleton
- Jointed appendages
- Segmented body
- Moulting;
22. a) Magnification – Ability of a microscope to enlarge tiny objects
Resolution – Ability of a microscope to separate between two tiny structures under magnification to appear distinct
b) Mounting – The placing of prepared slide on stage of a microscope;
Staining – Use of chemical stain on specimen for clear observation
23. (a) Golgi bodies/Golgi apparatus;
(b) Lysosome(s):
(c) Ribosomes;
24. (a) Make the sections transparent:
(b) To produce thin sections/ Not to distort the cells:
(c) To distinguish between different parts/organelles of the cells:
25. - Magnify the object further;
- Concentrates light onto the object;
- Controls amount of light illuminating the object;
26. Size of one cell = $\frac{\text{diameter of field view}}{\text{No. of cells arranged across the diameter}}$
$$= \frac{2000 \mu\text{m}}{10 \text{ cells}}$$
$$200 \mu\text{m} = 0.2 \text{ mm}$$
$$\text{N/B} = 1 \mu\text{m} = 0.001 \text{ mms};$$
27. (a) To make the specimen /section more visible
(b) To allow light to pass through for easy viewing
28. Animal cell;
29. a) Stores hydrolytic enzymes for destruction of worn out organelles/ cells/ tissues/ digestion of bacteria/ pathogens; Acc digestion of food/ accept autolysis
b) Processing/ packaging synthesized and transporting of packaged cell materials; production

of lysosomes/ secretions of packaged material;

30. Insecta; Reject insects/ exopoda
31. a) magnifying the image of the specimen;
b) Objective lens brings the image into focus and magnifies it;
32. a) Mitochondria
b) early production/ respiration;
c) Increases surface area; for attachment of respiratory enzymes;
d) Nerve cells; skeletal muscles; cardiac muscles

3. Cell Physiology – Osmosis, Diffusion and Active transport

1. a) A- The strip increased in length/ size; B - Decreased in length/ size;
b) The sugar solution was hypotonic to the cell sap strip A; it gained water by osmosis hence increasing in length;
2. (a) The potato cup will be filled with solution;
(b) The solution in the potato cells is hypertonic to the water; hence water moves into the cell by osmosis; this makes the solution in the neighbouring cells to be hypertonic to the outer cells; hence water moves from cell to cell until it eventually enters the potato cup;
3. (a) (i) Will lose water by osmosis and become plasmolysed;
4. Diffusion;
Osmosis ;
Active transport ;
5. a) $3.0 + 3.1 + 3.2 = 9.3$ g;
Average = $\frac{9.3}{3} = 3.1$ g;
b) The cell sap had a higher concentration of solutes than distilled water, water therefore moves from the environment to the cell by osmosis ;
6. (a) red blood cells placed in a hypertonic solution and as a result lost water to the surrounding thorough osmosis hence shrunk/crenated ;
(b) Appearance of that cell if subjected to the same condition
7. a) Haemolysis
b) Plant cell will lose water the cell sap to the outside solution by osmosis; the cell becomes plasmolysed/ flaccid; but it will retain its shape due to rigid cell wall;
8. a) Haemolysis ;
b) The plant cell will draw in water molecules by osmosis; it will swell and become turgid; but it will not burst because of the presence of cellulose cell wall;
9. i) Spermatozoon
 - Tail – For swimming in vagina tract
 - Numerous mitochondria – for provision of energy for swimming

- Streamlined – to reduce friction during movement
 - Haploid nucleus – for fertilization of haploid ovum
- Palisade mesophyll cell
- Numerous chloroplasts for photosynthesis
 - Narrow and cylindrical – packed in small space
 - Large sap vacuole for storage of manufactured food;

10. a) Prophase I Reject prophase alone
 b) Homologous Chromosomes side by side or Bivalency
 c)

Mitosis	Meiosis
One phase	Two phases
Diploid daughter cells	Haploid daughter
No chiasmata formation	Chiasmata formation; Any two correct

Trophism	Tactic response
Growth is involved or brought about cell division	Locomotary
Slow	Fast

Set -up	Sodium chloride concentration	Number of red blood cells	
		At start of experiment	At the end of the experiment
A	0.9%	Normal	No change in number
B	0.3%	Normal	Fewer in number

11. A-no change in; number because 0.9% sodium chlorine solution is isotonic to RBC/blood;
 B-fewer in number because 0.3% sodium chloride solution is hypotonic to RBC/blood therefore some water was drawn in to RDC by osmosis ;leading to haemolysis/boosting of RBCs

- b)i)number will not change;
 ii)RBC will appear small in size/wrinkled/crenated/shriveled/shrink; 1mk
 Rej. Flaccid/flabby/plasmolysed

12. (i) Paranchyma;
 (ii) Collenchyma;
 (iii) Xylem: and sclerenchyma

13. (a) X – hypotonic solution; ✓
 Y – hypertonic solution; ✓
 (b) A – haemolysis; ✓
 B – crenation /laking; ✓
 (c) The cell will maintain/retain its normal shape.

14. Absorption of mineral salts by root hairs from the soil; Translocation of food from leaves to other parts of the plant; movement of salts from one cell to the next;

15. (a) (i) Increased in length, absorbed water through osmosis, (since cylinder cells were hypertonic/ at higher concentration) and become turgid.
 (ii) Reduced in length, cylinder host water to the hypertonic sucrose solution/become flaccid.
 (b) (i) No change in length
 (ii) Cells are dead and cannot carry out osmosis.

- (c) - opening and closing of stomata
 - Support in plants
 - Movement of water from cell to cell
 - Feeding in insectivorous plants
 - Absorption of water by root hairs
 - Absorption of water in the intestines
 - Reabsorption of water in kidney nephron.
16. (a) (i) Nucleus
 (ii) Maintain the shape of the cell providing support to herbaceous plants; stores sugar and salts; (mark first one)
- (b) $\frac{0.5 \times 100}{8}$; 62.5 μm ;
- (c) Hypotonic solution;
 Accept -highly concentrated salt/sugar solution
- (d) The potato cell sap were lowly concentrated than the surrounding solution; hence lost water molecules by osmosis through the semi permeable membrane to become plasmolysed;
- (e) Re-absorption of water from the kidney tubules/ hence important in osmoregulation;
17. a) transpiration
 b) prevent evaporation of water from the surface
 c) the level of water dropper
 d) i) faster drop in water level ii) no change in water level;
 iii) slower/very slow drop in water level;
 e) another set up using a leafless twig;

4. Nutrition in (a) plants (b) animals

1. a) Condensation;
 b) water;
2. (a) Guard cells;
 (b) Cells walls are thicker on the inner side then the outer side; which enables them to pull inwards when the cells are turgid; contains chloroplasts that are able to photosynthesize and produce sugars which enable them to absorb water; (any two points)
 (c) Accumulation of carbon (IV) oxide in the leaf forms a weak carbonic acid; lowering the pH which favours conversion of sugar to starch; causing the guard wells to lose turgidity; and close;
3. (a) Stomata on the epidermic were blocked; thus no carbon (IV) oxide entered the heat; therefore photosynthesis did not take place;
 (b) Respiration; Excretion/ transpiration;
4. (a)

Etiolated plant	Normal plant
- Yellow leaves/stems	- green leaves/stems;
- small leaves	- large leaves;
- long inter-nodes and thin stems	- short internodes and thick stem;
- weak stem/feeble stem	- strong /firm stem;

- (b) Enables plants to grow faster towards light for photosynthesis;

5.

PLANTS	ANIMALS
- Make their own food through the process of photosynthesis	- Depend on plants and other animals for food;
- They do not move from one place to another	- They move from one place to another;
- Respond slowly to stimuli	- Respond faster /quickly to stimuli;

6. They have thick inner membrane and thin outer membrane to allow them to bulge outwards when turgid to open stomata; Have numerous chloroplasts, to carryout photosynthesis, forming sugars to control opening and closing of stomata;

7. Reaction A – condensation;
Enzyme Y – Sucrose;

8. - To emulsify fats;
- To provide an alkaline condition for enzyme activities;
- To provide an alkaline condition for enzyme activities;

9. Have stomata on upper surface;
- Large leaf surface to increase surface are for absorption of light;
- Presence of aerenchyma tissues, allows them to float on water hence accessing sunlight;

10. (a) – Protease;
- Lipase
(b) At 35°C optimum temperature for enzyme to act; at 15°C enzymes in active since temperature is low;

11. a) Goiter;
b) Scurvy;

12. Enzymes – Thrombin; Thromboplastin/ Thrombokinase;
Metal ion – Calcium ions;

13. a) Peristalsis;
b) Circular and longitudinal muscles on the wall of oesophagus and intestines contract alternately;
c) Roughage;

14. Long gut / many chambers to provide large surface area for digestion; bacteria in rumen has enzyme cellulase which digest cellulose (to glucose/ sugars).

15. Concentrated of the solutions separated by a semi-permeable membrane; existence of concentration gradient; temperature of the solution;

16. i) Pancreas; ii) Insulin;

17. a) Roughage;
b) Water, vitamins, mineral salts;

18. Photolysis – Splitting water into H^+ and oxygen gas;
 - Synthesis of ATP to be used during dark stage;
 - Synthesis of chlorophyll necessary for photosynthesis;

19.

Guard cells	Other epidermal cells
- Have chloroplasts/photosynthesize - Have thick inner walls/thin outer walls Bean shaped	- No chloroplasts/do not photosynthesize - Walls uniformly thickened block shaped (any correct pair)

20. (i) Biliverdin ; Bilirubin ;
 (ii) Emulsify fats;
21. a) Involuntary movement of food along the alimentary canal
 b) Rhythmic contraction and relaxation of the circular and longitudinal muscles along the gut;
22. a) i) Chloroplast;
 ii) Mitochondrion;
 b) Similarity — Both have a double membrane;
 Difference Chloroplast Mitochondrion;
 - Grana Cristae;
 - Stroma Matrix;
23. a) HCl — to hydrolyse complex sugar to simple sugar
 $NaHCO_3$ — To neutralize the HCl
 b) Disaccharides;
 c) i) Glucose;
 ii) Sucrose;
24. a) Sensory neuron;
 b) Cell body is off the axon;
 c) A — Conduct coming signals / Receives impulses;
 B — Receives impulses rough dendrites / coordinates the nerve cell;
 D — produce myelin sheath that protects and insulates the axon;
25. a) Increases surface area for attachment of respiratory enzymes;
 b) i) Intergrana;
 ii) Accept site 4 photolysis; contains chlorophyll pigment absorbs light;
26. a) Increases surface area of fats for purpose of digestion;
 b) Accept any two correct
 - Destroys any ingested pathogens;
 - Provides acidic media for protein digesting enzymes (pepsin);
 - Converts/ activates pepsinogen inactive form to pepsin;
27. Poison acts as competitive inhibitor for active site of respiratory enzymes; energy production for active transport of nitrates is impaired;
28. Rhizobium bacteria benefits by getting Shelter & carbohydrates;

- Leguminous plant obtains nitrates fixed by the bacteria;
- 29.
 - Enzymes amylase digests starch to maltose
 - Mucus lubricates food
- 30. They are converted to starch; then stored in organs and tissues;
- 31.
 - Guard cells have chloroplast;
 - They are bean shaped;
- 32.
 - Oxygen-releases to the atmosphere or used by plants for respiration;
 - Hydrogen-enter dark stage, where it combines with CO₂ to form simple sugar;
 - ATP- provide energy during the combination of hydrogen atoms with CO₂ in dark stage;
- 33.
 - a) to investigate the effect of boiled saliva on starch/to show the effect boiled/denature enzyme amylase has on starch;
 - b) A-brown colour/colour of iodine persists;
B- blue black/blue/dark colouration;
 - c) A-starch has been digested/starch has been broken down/amylase hydrolyses starch hence no colour changes;
B-enzymes/amylase denatured hence no starch digested;
- 34.
 - a)A-condensation;
 - B-hydrolysis;
 - b)Duodenum; (any correct Rj .wrong spelling)
-ileum;
- 35.
 - i)stroma
 - ii)side of light reaction of photosynthesis /site of water photosynthesis and adenosine triphosphate production (ATP)
- 36.
 - (i) (Vitamin D/calciferol);
 - (ii) Prevents rickets/Osteomalacia;
- 37.
 - a) Schistosomiasis/ Bilharzia:
 - b) -Has suckers for attachment to the host:
 - Has secondary host/snail to increase its chances of survival:/increase chances of transfer to several hosts;
 - Its larvae/Eggs produces lytic enzyme to soften the hosts tissues hence allow penetration into the host:
 - Larva covered with cysts to remain dormant for a long time;
 - Goes through various forms of lifecycle/miracidia. cercariae and redia to make it difficult to eradicate/increase chance of survival/transmission;
 - Adult produces chemical substances to cover the body to protect it against hosts defence mechanism;
 - Separate sexes to ensure dispersed eggs are fertilized before shed into blood vessels.
- 38.
 - (a) (i) Stomach
 - (ii) Presence of hydrochloric acid to provide acid conditions

- 39 (a) To investigate the effect of heat on salivary amylase.
 (b) A – The brown colour of iodine was retained because the starch was digested by enzyme amylase in the saliva; ✓ 1.
 B – The colour changed to blue black/black; because amylase in the saliva was denatured by heat;
40. (a) (i) stroma; ✓
 (ii) Granum; ✓
 (b) – Provide energy – ATP;
 - Provide H⁺ - ves H₂ GAS /atoms;
41. Midnight – There was no photosynthesis at night; and carbon IV oxide was not used hence the high concentration;
 Noon - Carbon IV oxide was used in photosynthesis and therefore CO₂ concentration dropped.
42. - By increasing the enzyme /substrate concentration;
 - By increasing the temperature below the optimum upto the optimum temperature;
 - Providing suitable /favourable /optimum pH.
43. (a) - Mode of feeding is herbivorous. Reject Herbivore
 - Absence of upper incisors but have hony pad
 (b) 30
44. Small mammals have large surface area to volume ratio; hence lose heat quickly to environment; to replace the heat , lost, their metabolism is high making them to feed more frequently
45. - Plants are able to synthetize their own food
 - Plants are able to use pollination rather rhan moving to seek mating partners
 - Use seed and fruits dispersal to colonize new habitats (3x1=3mks)
46. a) A- Rhizome
 B- Adventitious roots
 (b) The liverwort body form is thalloid while the fern has 3body parts, roots, stem and leaves
47. The break down of glucose into pyruvic acid
48. (a)

Monosaccharide	Polysaccharides
- Are soluble in water	- Are insoluble in water
- Form sweet tasting solution	- Do not have a sweet taste
- Reduce Copper(II) ions in benedicts solution to Copper (I) ions when heated together	- They do not reduce
- Are crystalizable	- Are not crystallizable

(b) Peptide

49. H⁺/H atom; rej H₂/Hydrogen gas
 - ATP/energy
50. Absorption of water; accept absorption of salts/ calcium/ iron; secretion of mucus;

51. a) To show that light is necessary for photosynthesis;
b) Only the uncovered areas turned blue- black with iodine; the part covered with aluminum foil did not receive light and thus could not carry out photosynthesis;
52. a) As the temperature increases, the rate of the reaction also increases; this happens because an increase in temperature increases molecular movement, thus increasing the chances of collision between the enzyme and substrate molecules;
b) X – is the optimum temperature/ It is the temperature at which the reaction proceeds
53. Nitrogen;
Magnesium;
Iron;
54. a) A- Hook;
B – Sucker;
C – Youngest proglottid;
b) Intermediate host – pig;
55. a) A – Villus
B- Lacteal
b) A __ Increases surface area for maximum digestion and absorption;
B – Absorption of fatty acid and glycerol;
c) - Final digestion of undigested foods;
- Absorption of soluble end products of digestion;
d) Produces bile juice which contains bile salts that emulcify fat;
e) Produces insulin and glucagons hormones;
Reject if only one hormone is mentioned
56. (a) Rapid increase (in water of photosynthesis) due to increase in concentration of CO₂
(b) Constant rate/no increase rate and no decrease, other factors /light/temperature water become limiting/inadequate.
(c) chlorophyll traps energy.
Light energy react water into hydrogen ions and oxygen/photolysis.
Hydrogen is picked by hydrogen.
Acceptor/NAD/NADP (and becomes reduce, * ACCEPT NADPH,NADPH
ATP adenosine triphosysbate formed.
57. (a) Compensation point
(b) (i) There is no net uptake or release of Carbon (VI) oxide by the plant;
(ii) The rate of respiration and photosynthesis in the plants are equal; therefore all the Carbon (VI) Oxide released during respiration is used in photosynthesis;
(c) At light intensity beyond/above X, the rate of photosynthesis is higher than the rate of respiration; and this requires a net uptake of Carbon (IV) Oxide (to sustain the increasing rate of photosynthesis);
(d) Growth would cease because all the products of photosynthesis would be utilized in respiration;
(e) The plant will take up oxygen from the surrounding air since the rate of respiration is higher than the rate of photosynthesis;

58. (a) Broad and flat to absorb maximum light
 Have chloroplast with chlorophyll to trap light.
 Transparent cuticle to allow light to pass through
 (b) X – Carbon (IV) Oxide
 Y – Oxygen
 (c) Xylem – Transports water
 Phloem – Sugars out of the leaf
 (d) Starch is insoluble in water, hence osmotically inactive; This reduces effect on absorption of water.

59. a) breakdown of complex food, substance; into simple diffusible substances;
 b) intestines relatively long/coiled /folded ;this allows food enough time for absorption.
 Intestines long /have villi; to increase the surface area for absorption and digestion ;
 The walls have glands which secrete enzymes for digestion;(examples of correct enzymes e.g. Maltase, sucrose lactose etc).some glands /goblet cells also produce mucus; which protects The intestinal wall from autodigestion/being digested; and reduce friction;
 Intestines have opening of ducts which allows bile pancreatic juice into the lumen;
 The intestines have circular and longitudinal muscle, whose contraction and relaxation/peristalsis;
 Leads to mixing of food with enzymes/juice; facilitating rapid digestion and help push food along the gut; the intestines are well supplied with blood vessels to supply oxygen/ remove digested food from an efficient absorption and transporting system to move the food away from the small intestines;
 Have lacteal vessels for transport of fat/lipid; have thin epithelial lining; to facilitating fast absorption /diffusion;

Note. Allow increases in surface are for absorption only once

60. (a) To investigate the rate of photosynthesis;
 (b) It is used to draw the bubbles of gas through the apparatus;
 (c) (i) Oxygen gas;
 (ii) $6\text{CO}_2 + 6\text{H}_2\text{O} \xrightarrow[\text{Chlorophyll}]{\text{Light energy}} \text{C}_6\text{H}_{12}\text{O}_6 + 6\text{O}_2$

Acc. Either word or chemical equation

If chemical, must be balanced, symbols capital.

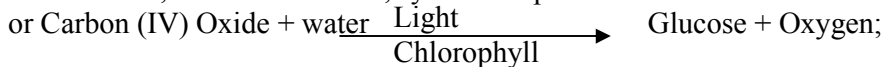

- (d) - Optimum
 - Optimum PH
 - Absence of inhibitors.
 - Presence of co-factors or co-enzymes.
 - Low substrate concentration.
 (e) - To minimize temperature changes.
 61. a) A- Rhizome
 B- Adventitious roots
 (b) The liverwort body form is thalloid while the fern has 3body parts, roots, stem and leaves
 62. The break down of glucose into pyruvic acid

63. (a)

Monosaccharide	Polysaccharides
- Are soluble in water	- Are insoluble in water

- Form sweet tasting solution	- Do not have a sweet taste
- Reduce Copper(II) ions in benedicts solution to Copper (I) ions when heated together	- They do not reduce
- Are crystalizable	- Are not crystallizable

(b) Peptide

64. H^+ /H atom; rej H_2 /Hydrogen gas
- ATP/energy
65. Absorption of water; accept absorption of salts/ calcium/ iron; secretion of mucus;
66. a) To show that light is necessary for photosynthesis;
b) Only the uncovered areas turned blue- black with iodine; the part covered with aluminum foil did not receive light and thus could not carry out photosynthesis;
67. a) As the temperature increases, the rate of the reaction also increases; this happens because an increase in temperature increases molecular movement, thus increasing the chances of collision between the enzyme and substrate molecules;
b) X – is the optimum temperature/ It is the temperature at which the reaction proceeds
68. Nitrogen;
Magnesium;
Iron;
69. a) A- Hook;
B – Sucker;
C – Youngest proglottid;
b) Intermediate host – pig;
70. a) A – Villus
B- Lacteal
b) A __ Increases surface area for maximum digestion and absorption;
B – Absorption of fatty acid and glycerol;
c) - Final digestion of undigested foods;
- Absorption of soluble end products of digestion;
d) Produces bile juice which contains bile salts that emulcify fat;
e) Produces insulin and glucagons hormones; Reject if only one hormone is mentioned
71. (a) Rapid increase (in water of photosynthesis) due to increase in concentration of CO_2
(b) Constant rate/no increase rate and no decrease, other factors /light/temperature water become limiting/inadequate.
(c) chlorophyll traps energy.
Light energy react water into hydrogen ions and oxygen/photolysis.
Hydrogen is picked by hydrogen.
Acceptor/NAD/NADP (and becomes reduce, * Accept NADPH, NADPH
ATP adenosine triphosybate formed.
72. (a) Compensation point
(b) (i) There is no net uptake or release of Carbon (VI) oxide by the plant;
(ii) The rate of respiration and photosynthesis in the plants are equal; therefore all the Carbon (VI) Oxide released during respiration is used in photosynthesis;
(c) At light intensity beyond/above X, the rate of photosynthesis is higher than the rate of

respiration; and this requires a net uptake of Carbon (IV) Oxide (to sustain the increasing rate of photosynthesis);

- (d) Growth would cease because all the products of photosynthesis would be utilized in respiration;
- (e) The plant will take up oxygen from the surrounding air since the rate of respiration is higher than the rate of photosynthesis;
73. (a) Broad and flat to absorb maximum light
Have chloroplast with chlorophyll to trap light.
Transparent cuticle to allow light to pass through
- (b) X – Carbon (IV) Oxide
Y – Oxygen
- (c) Xylem – Transports water
Phloem – Sugars out of the leaf
- (d) Starch is insoluble in water, hence osmotically inactive; This reduces effect on absorption of water.
74. a) breakdown of complex food, substance; into simple diffusible substances;
b) intestines relatively long/coiled /folded ;this allows food enough time for absorption.
Intestines long /have villi; to increase the surface area for absorption and digestion ;
The walls have glands which secrete enzymes for digestion;(examples of correct enzymes e.g. Maltase, sucrose lactose etc).some glands /goblet cells also produce mucus; which protects The intestinal wall from autodigestion/being digested; and reduce friction;
Intestines have opening of ducts which allows bile pancreatic juice into the lumen;
The intestines have circular and longitudinal muscle, whose contraction and relaxation/peristalsis;
Leads to mixing of food with enzymes/juice; facilitating rapid digestion and help push food along the gut; the intestines are well supplied with blood vessels to supply oxygen/ remove digested food from an efficient absorption and transporting system to move the food away from the small intestines;
Have lacteal vessels for transport of fat/lipid; have thin epithelial lining; to facilitating fast absorption /diffusion;
Note. Allow increases in surface are for absorption only once
75. (a) To investigate the rate of photosynthesis;
(b) It is used to draw the bubbles of gas through the apparatus;
(c) (i) Oxygen gas;
(ii) $6\text{CO}_2 + 6\text{H}_2\text{O} \xrightarrow[\text{Chlorophyll}]{\text{Light energy}} \text{C}_6\text{H}_{12}\text{O}_6 + 6\text{O}_2$
- Acc. Either word or chemical equation
If chemical, must be balanced, symbols capital.
or Carbon (IV) Oxide + water $\xrightarrow[\text{Chlorophyll}]{\text{Light}}$ Glucose + Oxygen;
- (e) - Optimum
- Optimum PH
- Absence of inhibitors.
- Presence of co-factors or co-enzymes.
- (e) - To minimize temperature changes.
76. (a) The bacteria ad exhausted the available food materials and they died;

- (b) They multiply very fast as they feed on the substances; release toxic waste on food then die there causing food spoilage
- (c) fungi;
- (d) – Speed up recycling of matter in the ecosystem;
 - Breaks down /decompose dead complex organic matter

77. (a) Graph:

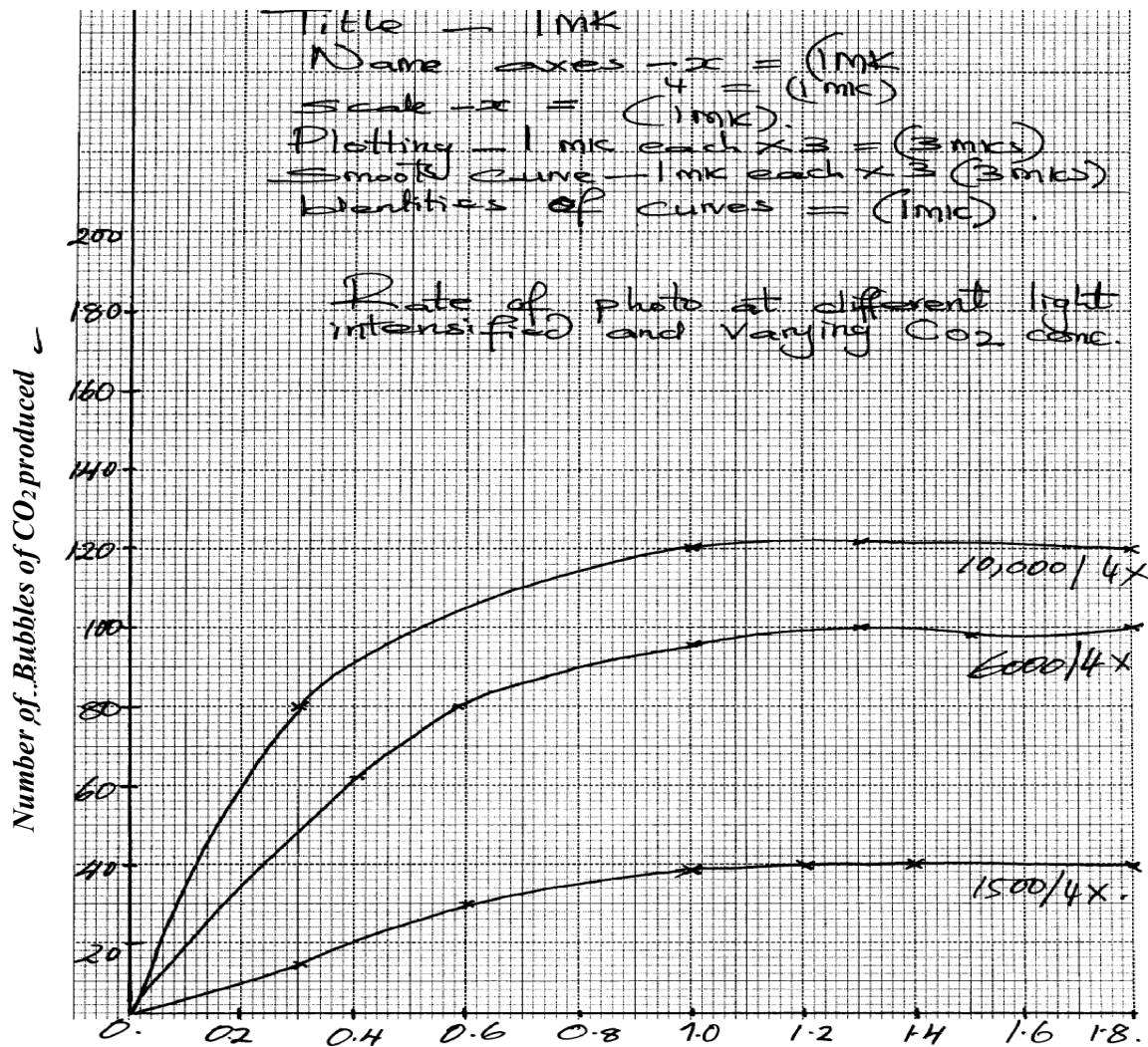

78.

- Is relatively long/ cooled/ folded to allow food (enough) time/ increase surface area for absorption of digested food and for digestion
- Lumen has projection called villi; villi has projections called microvilli; to increase surface area for absorption
- Walls have glands which secrete enzymes for digestion; e.g. maltase/ sucrose/ lactase/ enterokinase/ peptidases
- Some glands/ goblet cells produce mucus; which protects the intestinal wall from being digested and also reduce friction
- Have openings of ducts which allow bile/ pancreatic juice into the lumen
- The intestines have circular and longitudinal muscles; whose contraction and relaxation/ peristalsis leads to mixing of food with enzymes/ juices; facilitating rapid digestion; and helps push food along the gut
- Intestines are well supplied with blood vessels/ highly vascularized; to supply oxygen/ remove digested food
- Lacteal vessels; transport fats/ lipids
- They have thin epithelia; to facilitate fast/ rapid absorption/ diffusion

79.

- (a) To destarch the plant leaves;
- (b) (i) To absorb carbon (iv) oxide in the flask;
- (ii) To enrich the air in the flask with carbon(iv) oxide;
- (c) (i) leaf M – Sodium Hydroxide absorbed Carbon (IV) oxide in the flask;
 - No photosynthesis occurred and so the leaf retained the brown colour of Iodine;
- (ii) Leaf N – Sodium hydrogen carbonate enriched the flask with carbon (IV) oxide;
- Photosynthesis occurred and starch formed reacted with iodine to give the leaf the characteristic blue-black colour;
- (d) Conical flask covered with aluminium foil and no sodium hydroxide or sodium hydrogen carbonate;

80.

- a) Graph
- b) i) $2.5 - 2.7$; i.e. $2.6 + 0.1$
- ii) $4.5 + 0.1$
- c) - Volume of CO_2 consumed/ volume of O_2 liberated
- Change in dry mass (due to photosynthesis);
- d) - Photolysis of water
- ATP synthesis
- e) i) Rate of photosynthesis very low
- Enzymes inactivated
- ii) Rapid rate of photosynthesis
- Optimum temperature for enzyme reaction
- iii) Very low rate of photosynthesis
- Enzymes denatured
- f) Chlorophyll concentration (in leaves)
- CO_2 concentration
- Water availability

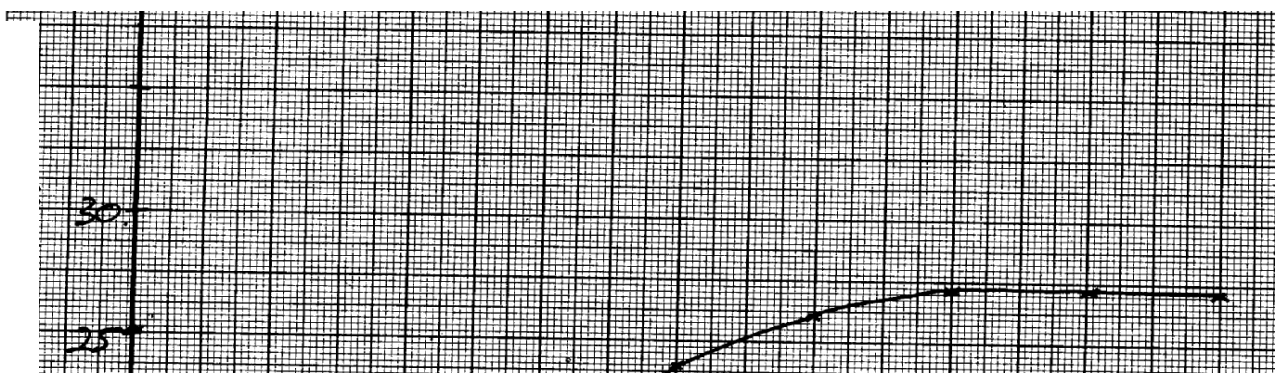

LIGHT INTENSITY

79. a) i) to kill cells/expose starch gradually/stop biology processes;
ii) to decolourise the leaf/to dissolve chlorophyll;
b) i) leaf retained brown colour of iodine;
ii) starch was absent (since no photosynthesis had taken place);
c) to investigate the necessity of light in the process of photosynthesis;
d) to soften the leaf and wash off alcohol;
e) leaf with some parts/patches looking chlorophyll;
f) water + carbon(iv)oxide $\xrightarrow[\text{chlorophyll}]{\text{light}}$ Glucose + oxygen;
(carbohydrate)

5. Transport in (a) plants (b) animals

1. On a hot sunny day blood vessels are dilated hence more blood is lost; on a cool chilly day the blood vessels have constricted hence less blood flows on the surface of the skin;
2. - Biconcave disc shaped to increase surface area for gaseous exchange;

- Have no nucleus to increase room for the package of red blood cells;
 - Numerous in number to increase surface area for the transportation of oxygen
 - Have haemoglobin which has a high affinity of oxygen;
 - Cytoplasmic filaments/strands along which food streams;
 - Companion cells have mitochondria that provide energy for translocation;
 - Sieve plates with sieve pores through which cytoplasmic filaments pass.
 - Photoplasmic material pushed on the sides to create lumen space for translocation;
4. (a) Chitin;
(b) Lignin:
- Root pressure;
- Cohesion – adhesion forces
 5. Transpiration pull;
 6. (a) – transpiration pull;
- Cohesion and adhesion;
- Capillarity;
- Root pressure;
(b) Phloem;
 7. (a) (i) $(15 \times 2) = 30$;
(ii) Carnivorous; reject carnivore
(b) – To lubricate the food;
- To protect the alimentary canal wall from digestion by protein digesting enzyme /protoelytic enzyme;
- Make the food adhere together during swallowing;
 8. (a) Thoraic vertebrae;
(b) B – Neural canal;
C – Centrium;
(c) For attachment of back muscles;
 9. - Growing regions (e.g meristems); storage organs for storage (e.g stems, roots, fruits)
- secretory organs (e.g. flower nectarines);
 10. A, AB, B, O; for all blood groups
 11. (i) Efficient diffusion of substances e.g. food, gases and waste products;
(ii) Efficient transport of food/gases/waste products to and from cells;
 12. (a) Transpiration;
(b) (i) The level of water in the boiling tube reduced significantly;
(ii) The level of water did not reduce;
 13. Aerenchyma tissues have large and numerous air spaces; hence facilitation buoyancy;

Arteries	Veins
- Thick muscular - No valves (except pulmonary artery and aorta)	- Thin muscular walls - valves present;

14. a)	at the base - Narrow (small) lumen	- Wide lumen (large) lumen;
--------	---------------------------------------	-----------------------------

b) Arteriosclerosis; reject Artheroma

15. Transpiration pull; Cohesion and adhesive forces; Capillarity; Root pressure;

16. -numerous to increase surface area
-Biconcave to increase surface area for packaging hemoglobin alter shape to fit narrow lumens of capillaries;
-No nucleus to increase surface area for oxygen leading;
-Have hemoglobin which has high affinity for oxygen;

17. a) Tissue fluid is a fluid / liquid found surrounding cells/ between cells formed as a result of ultra filtration from blood while lymph is inter cellular fluid which nutrients and oxygen have been taken and is rich in waste materials (mark as a whole)
b) Vitamin K is needed for formation of prothrombin which is activated to thrombin which helps in clotting of blood.

18. Open circulatory system

19. Coronary Artery;

20. a) Oxyhaemoglobin;
b) Use oxygen released from photosynthesis process;

21. Leukemia (acc. blood cancer)

22. (a) Diabetes mellitus
(b) - Symptoms of diabetes mellitus
- Passing urine frequently;
- Constantly feeling thirsty;
- Dehydration;
- Loss of weight;
- Poor resistant to infection;

23. (a) A – Tracheid; B – Vessel;
(b) - Side walls are impregnated wit lignin/deposited with lignin /walls are lignified/pressure of lignin nucleus not enclosed by a membrane ;

24. There is high concentration of water vapour around the leaf/less space for water vapour form the leaf to occupy low saturation deficit /low diffusion gradient / the diffusion between the concentration of water vapour in the atmosphere and the air spaces is greatly reduced.

25. a) Transports water and dissolved mineral salts; provides mechanical support due to lignification of cells
b) Narrow lumen of vessels and tracheids – enhances capillarity forces;

Presence of pits on lignified walls follows for lateral movement of water;
They are hollow to allow uninterrupted/ continuous flow of water from roots to leaves;

26. a) Involuntary movement of food along the alimentary canal
b) Rhythmic contraction and relaxation of the circular and longitudinal muscles along the gut;
27. a) A – Hepatic portal vein; B- Hepatic artery;
b) Excess glucose must be converted to glycogen; for storage
c) Burning charcoal produces carbon (II) Oxide which combines with haemoglobin to
28. a) Oxyhaemoglobin
form carboxyhaemoglobin that is stable/ does not dissociate; reducing efficiency of haemoglobin in carrying oxygen leading to death; Ref death alone
leaf fall;
exudation;
guttation;
transpiration
29. - Sebum – from sebaceous glands – antiseptic ;
- Confined layer of dead cells- impenetratable by bacteria/ fungi/ viruses
- Sweat – saline and kills bacteria and viruses
30. Leukamia/ blood cancer;
31. a) inversion;
b) mustard gas/ gamma rays/ x-rays/ beta rays/colchicines;
32. (a)(i) Dicotyledonae;
(ii) Star shaped xylem/phloem between the arms of the xylem;
(b) Lignified walls to prevent it from collapsing/keep it hollow open throughout:
- Hollow/Lack cross walls for continuous flow of water and mineral salts any 1
- Narrow Lumen to enhance capillarity;
33. - Creates transpiration pull:
- Absorbs latent heat of vaporization hence cools leaves of the plant: (2marks)
34. Water absorption does not involve active transport that requires energy from respiration facilitated enzymes ; hence no metabolic inhibition involved;
35. (a) A – Tracheids ; B – Xylem vessel;
(b) B is hollow at the middle therefore the substance flowing through it gets to their destination faster as compared to that of A; ✓
(c) – Lignification ; ✓
36. - Antigen B;
- Rhesus antigen / Rhesus factor /rhesus protein;
37. After the first transfusion the patient would produce rhesus antibodies; second transfusion rhesus antigen would react with rhesus antibodies; causing agglutination;
38. (a) Pseudopodium; ✓
(b) Phagocytosis; ✓

- (c) White blood cells.
39. (a) Xylem vessels are hollow (lack cross walls) , hence more efficient in transporting water than tracheids which have trapped ends with perforation;
 (b) Xylem vessels are dead due to heavy lignification on their walls hence provision of support to the plant as well preventing collapse ;
40. Transpiration is the loss of water vapour, while gutation is loss or exudation of liquid water through hydathodes
41. Support
42. – Storage of air
 - For buoyancy
43. (a) A blood disorder where red blood cells appear sickle shaped
 (b) Sinoatrio node/pace maker
44. a) To generate high pressure to pump blood; to all parts of the body/ to furthest distance;
 b) Hydrogen carbonate (HCO_3)
 Carbonic acid;
45. a) Sunken stomata form pits; in which water vapour accumulates reducing rate of transpiration
 b) Water proof to reduce the rate of transpiration;
46. a) Lignin;
 b) Phloem;
47. a) A – Transport of organic food substances from sites of manufacture;
 B – Formation of new xylem and phloem tissues;
 C – Transport of water and mineral salts from the roots to the leaves;
 b) Parenchyma cell;
 c) Sclerenchyma;
48. - Blood cells;
 - Plasma proteins;

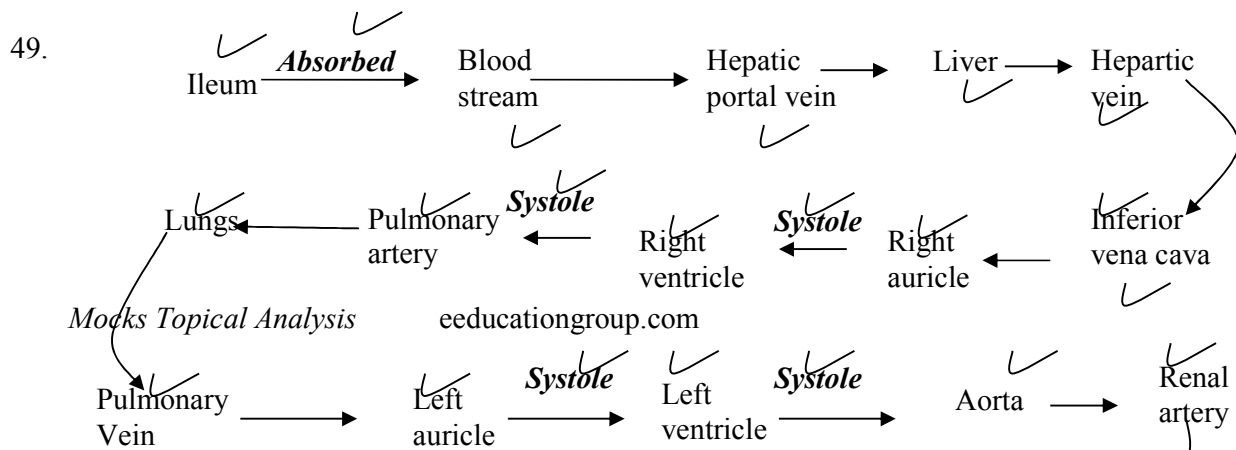

- | | | |
|--|-----------------------|----------------------------------|
| | Acc. Descriptive form | Rej. – From appoint of a mistake |
|--|-----------------------|----------------------------------|
50. (a) - Blood group O is a universal donor (as it donates to all other blood groups); *UGU*
- Blood group AB a universal receipt (as they receive blood from all other groups.
 - Blood group A can receive blood from group O and A only.
 - Blood group B can receive blood from O and B only.
 - Blood group O does not receive blood from other blood groups except O.
 - Compatibility of blood group
 - Absence of pathogens in blood.
 - The Rhesus factor matches.
- (c)- When blood vessel is injured, exposed platelets rupture to release thromboplastin (enzymes); which converts prothrombin to thrombin; in presence of Ca^{2+} thrombin activates conversion of fibrinogen into fibrin; which forms mesh work of fibre in the cut surface;
51. a) Measure rate of transpiration;
- b) -Assemble apparatus under water;
- Apply vasectomy between cork shoot contacts;
 - Open the reservoir tap;
- c) i) The air bubble will not move
- ii) Water droplets will be seen in he polythene;
- iii) Air bubble will move faster
52. (a) (i) $\frac{(23000 - 100)}{1100} \times 100 = 1,990\%$;
- (ii) $\frac{(1300 - 400)}{1300} \times 100 = -6.92\%$;
- (b) (i) At rest, the gut is more active than skeletal muscles as this is the time when digestion is taking place; more blood goes to gut to transport the absorbed food;
- (ii) During strenuous exercise, skeletal muscles are more active; and a lot of blood is diverted to help it contract and relax while very little blood flow through the gut which becomes less active;
- (c) During light exercise, the skin becomes more active; thus give the highest blood flow compared to other times to release excess heat, sweat and wastes.
- (d) – Excess water;
- urea, ammonia, uric acid; (OWTTE)
53. a) A- Epidermis
- B- Pith
- b) C- Transports manufactured food/ products of photosynthesis/ translocates food
- E- Transports water and mineral salts
- c)

Section above	Section from root
Xylem/ phloem form around cambium	Xylem star shaped and centrally placed
Pith at the centre	No pitch
Roof hairs absent	Roof hair present
Epidermis has cuticle	Epidermis has no cuticle

54. Geographical distributed of organism;

Theory supposes that at sometime the present day continents found a large single land mass; animals migrated freely all over the land mass; the land broke up into parts which drifted from one another forming the present day continents; this drive isolated animals from common ancestry; leading to the formation of new differed species distinct; from those found in other climatically similar but separate regions.

Comparative embryology;

Embryos of different groups have been found to have similar morphological feature during their early stages of development. This similarly suggest a common ancestry

Comparative anatomy;

When comparing the firm and structure of different organism; some groups shows basic structural similarities; which suggest a common ancestry as observed in homologous and analogous structures

Homologous structures are those that have common embryonic.... But are modified to perform different functions e.g. vertebrate fore limbs

Analogy structure those that have different embryonic origin bad have evolved to perform similar functions due to exploitation of similar environment e.g. bad and insect wing)

Cell biology;

Cells of all higher organism show basic similarities in their structure and functions; cell membrane and cell organelles such as ribosomes; biological chemicals in common e.g. ALP & DNA. This strongly indicate that all cell types have a common ancestral origin

-blood pigments among also show the same ancestral origin

Comparative serology;

Analysis of blood proteins and the antigens to reveal phylogenetic relationship. Those species that are more phylogenetical reacted contain more similar blood proteins

An immunological reaction between human beings and chimpanzees produces a lot of precipitate showing a close phylogenetic relationship

-red blood cells; carry oxygen; to all parts of the body/from lungs /to tissues; transport CO₂; to lungs /from tissues;

-platelets/thrombocytes; produce in enzymes/thrumbokinace /thrumboplastin; necessary for blood clotting;

-leucozytes/W.B.C; produces antibodies for defense against disease; they also engulf foreign bodies/pathogens;

-plasma; transport nutrients; hormones; distribute heat; carbon(iv)oxide; nitrogenous waste/urea; mineral ions; fibrinogen; plasma bathes the tissues allowing for exchange of materials

Acc. Plasma proteins for fibrinogen (20)

6. Gaseous exchange in (a) plants (b) animals

1. a) Alveoli
- b) Thin walled/ epithelium highly vascularised, has large surfaces area; moist;

2. It does not easily dissociate; thereby reducing the capacity of haemoglobin to transport *KKE* oxygen;
3. Smoking; Diet with lots of fats and carbohydrates/cholesterol fat; (2mks) *KKE*
4. - Carbonic anhydrase; facilitates formation of /ionization of carbonic acid;
- It has haemoglobin which readily combines with bicarbonate.
5. (a) The ratio of the amount/volume of Carbon (IV) Oxide produced to that of oxygen consumed during respiration;

(b) (i) $RQ = \frac{\text{Vol. of CO}_2 \text{ produced}}{\text{Vol. of oxygen consumed}}$
= $\frac{102}{145}$
= 0.703;
(ii) Fats;
6. Gill filaments are thin/one cell thick to facilitate faster/rapid diffusion of respiratory gases; the surfaces of the gill filaments are moist to facilitate dissolution of respiratory gases ; The gill filaments are numerous to provide a large surface area for gaseous exchange; the gills have numerous rakers that filter food/solid particles that may damage the gill filaments; The gill has a gill bar which is long and curved to provide a large surface area for attachment of gill filaments; the gill is highly vascularised to ensure efficient transport of respiratory gases;
7. (i) Cell membrane;
(ii) Lenticels;
(iii) Skin, lungs and mouth cavity;
8. a) (Moist) skin/ buccal cavity; lungs; mark the first two
b) – (oxygen) dissolves in the water film; in the tracheoles; and diffuses in to the haemolymph (along the concentration gradient)
9. a) Increased rate of breathing; increased rate of heart beat;
b) Mitochondrion;
10. - Importance of counter current flow in fish : - It maintains a steep concentration gradient across the respiratory surface; thus ensuring there is a maximum exchange of O₂ from water to the blood;
11. Four adaptations of red blood cells
 - -lack of nucleus to create large surface area for dense packing of haemoglobin required for oxygen transportation;
 - Have biconcave shape to provide large surface area for oxygen transportation;
 - have thin membrane to facilitate rapid diffusion of respiratory gases;
 - have numerous /many haemoglobin densely packed to increase the rate of oxygen transportation;
 - are pleomorphic /can change shape easily thus can squeeze through narrow capillaries;
12. a) i) Cytoplasm
ii) Pyruvic acid

- b) Pyruvic acid is broken down; into ethanol and CO₂
13. - Ribcage moves upwards and outwards;
- Diaphragm muscles contracts; hence;
- Diaphragm flattens;
14. a) Process of movement of food substances from site of manufacture to other storage organs
b) - Capillarity
- Root pressure
- Transpiration pull
15. -PH of blood, plasma is not altered homeostasis maintained;
-Within RBC there is an enzyme (carbonic anhydrate) which helps in fast loading / dissociation / combination and offloading/dissociation of CO₂; (award 1st two2mks)
16. Have lenticels: for gaseous exchange: *
17. - Moist;
- Thin epithelium; Mark 1st two
- Highly vascularised:
- Large surface area;
18. (a) Create more room/space for packing of more haemoglobin:
(b) To provide a large surface area for diffusion of a lot of respiratory gases:
19. -Increase in Red blood cell count/Total number of red blood cells;
- Increase in haemoglobin content of RBC
20. Distilled water is hypotonic to RBC (OWTTE); hence water is absorbed by osmosis; the RBC bursts haemolysis (due to absence of cell wall)
21. (a) Numerous/ many;
(b) Long:
(b) Blood in the gill filaments flow in the opposite direction to water over the gill filaments: to create a deep diffusion gradient; for rapid ?faster diffusion of respiratory gases:(2marks)
22. When the rubber plug is pulled there is an increase in volume and decrease in pressure in the syringe; Therefore due to this the atmospheric pressure exceeds the pressure in the syringe case causing air to flow in the balloon; leading to the increase in size of the balloon;
23. - Air containing oxygen from the atmosphere gets to trachea; through spiracles; on to the tracheoles from where it diffuses; to the tissue;
24. (i) Moist to dissolve respiratory gases prior to diffusion;
(ii) Thin to reduce the distance through which diffusion has to take place/to facilitate rapid diffusion;
25. (a) Adds carbon dioxide to the water
(b) At evening the light intensity has reduced hence reduction in the rate of photosynthesis.
(c) Water plants are able to extract dissolved carbon(IV)oxide in water (1x1=1mk)

26. (a) - Red blood cells are biconcave in shape increase surface area to pack more haemoglobin
- They are numerous for efficient transport of oxygen
- Red blood cells lack nucleus, creating large surface area to more haemoglobin
(b) – In form of hydrogen carbonate by plasma, carboamino haemoglobin or carbonic acid in plasma
27. a) A – Ciiil rackers act as a screen preventing entry of food and other particles that might damage the delicate gill lamella;
B – Gill bar for attachment of gill rakers and gill filament
C – Gill filaments – the surface on which gaseous exchange take place
b) Filaments are supplied wit a dense network of blood capillaries for the efficient transport of gases;
28. - Ventilated through spiracles on either side of the insects body;
- Trachea branches too numerous tracheoles increasing the surface area for gaseous exchange;
- Tracheoles are moist to allow gases to diffuse in solution form;
- Tracheoles membrane is very thin to provide a short distance for diffusion
- Trachea has circular rings of chitin to prevent collapsing. This keeps the air passages always open;
- Spiracles have valves to enhance movement of gases into the trachea, and also to prevent drying of the trachea;
29. - Active immunity is immunity that is produced when an animal’s body reacts to an antigen by producing antibodies;
- Passive immunity is immunity that is produced when antibodies are transferred from one individual to another;
30. - Lenticels;
- Cuticles
- Mesophyll cells/ spongy mesophyll/ palisade mesophyll/ stomata/ substomatal chambers;
31. a) Ventilation
b) i) lower concentration of oxygen in high altitude areas; raises the demand of oxygen by body cells
ii) Number of red blood cells has increased; hence enough oxygen is reaching all body cells adequately
c) Has a higher capacity of transporting enough oxygen to body cells; due to higher number of red blood cells; in the body (has lower oxygen demand)
d) i) Muscle cramps; Muscle fatigue
ii) It is completely oxidized by oxygen to form water, carbon IV oxide and energy;
32. a) Red Blood Cells
- Lacks nucleus to provide greater space for packing more haemoglobin; oxyhaemoglobin;
- Thinner membrane for faster diffusion of gases through a shorter distance
- Biconacave to increase the surface area for maximum transport of gases
- Shorter life cycle for increasing more efficiency in gass transport;
- Numerous to increase the surface area for maximum transport of gases;
White blood cells - Have a lobbed nucleus to carry out engulfing and digestion process of pathogens more effectively
Platelets - Has thromboplastic enzyme which catalyses the activation of prothrombin to thrombin during blood clotting process;
FibrinogenIt is highly sensitive to thrombin whose presence changes it into insoluble fibrin;
Plasma - Has water with a high specific heat capacity which enables it to maintain the temperature of the body within a narrow range
- Water also dissolves and act as a medium of transport of dissolved substances;
33. (a) Stomata; cuticle; lenticels; any two

- (b) Spongy mesophyll layer; Palisade mesophyll; sub-stomatal air spaces/chambers;
 - (c) Foliage leaf – photosynthesis;
scale leaf v - protection;
floral leaf – attraction of agent of pollination/photosynthesis;
cotyledon leaf – storage of food / photosynthesis
 - (d) Guard cells photosynthesize food, accumulate monosaccharide and become osmotically active; they absorb water from neighbouring epidermal cells and stoma opens as they expand/swell;
34. (a) Path A (Nose) has mucous lining which trap foreign particles in air; has sensitive cells to smell in nose limit inhalation of poisonous gases; air is warmed in the nose before reaching the lungs; hair in the nose filter solid particles in the air;
- (b) Has a lumen/tubular for air passage; has mucous membrane to trap foreign particles and filter dust; Has cartilage to prevent collapsing / to keep it open; Has elastic muscles to allow compression and flexibility;
- (c) Soot/smoke particles block the passage (bronchi/alveoli) of the gases; may cause cancer /stimulate the epithelium membrane/lining to secrete a lot of mucus which may block the passage;
35. (a) Adaptations of the air ways (trachea and bronchi)
- The walls of the trachea and bronchi are lined by rings of cartilage; which prevent them from collapsing and keep them open for air passage;
 - The inner passage of air ways is lined with mucous membrane; which contain ciliated cells; whose movements to and from the pharynx cause a sweeping action that collects mucus containing dust towards the pharynx hence preventing their entry into the air ways;
 - The mucous membrane contains mucus secreting cells; which produce mucus that trap dust and pathogenic particles which would find their ways into the air ways;
 - The mucous membrane has a rich supply of blood; which helps to keep the incoming air warm and moist for easy diffusion into the lungs;
 - The epiglottis and other structures on top of the trachea prevent food, drinks and other soil particles from going into the trachea during swallowing;

Adaptations of the lungs

- It has numerous alveoli; that provide a large surface area for efficient gaseous exchange;
- Epithelial lining between alveoli wall and the blood capillaries is thin; to provide a shorter diffusion distance for easy gaseous exchange;
- The lung is spongy and has numerous air sacs; that accommodate large volume of gases (oxygen);
- It is highly supplied with blood capillaries that transports oxygen and carbon (IV) oxide to and from the body tissues respectfully;
- Its epithelial lining is covered by a thin layer of moisture; to dissolve oxygen for easy diffusion into the blood stream;
- The lung is connected to tree – like system of tubes (the trachea, bronchi and bronchioles); that supply oxygen and removes carbon (IV) oxide from the lung;
- The whole lung is covered with the pleural membrane which is gas-tight thus changes in pressure within the lungs can occur without external interference; N/B- Mark as a whole)

(b) Opening

- In the guard cells there are chloroplasts; which carry out photosynthesis in the presence of light; (in the day)

- During photosynthesis glucose is produced in the guard cells; this increases osmotic pressure; compared to the neighbouring epidermal cells; water then moves into the guard cells by osmosis; and increases their turgidity;
- The inner walls of guard cells are thicker than the outer walls; so outer walls stretch more than the inner walls causing guard cells to bulge outwards causing the stomata to open;

Closing

- During the night when there is no light; no photosynthesis takes place in the guard cells; Glucose in the guard cells is converted into starch; this lowers the osmotic pressure of the guard cells than the neighbouring cells;
- Water is then drawn away from the guard cells by osmosis; into the neighbouring cells, making them to be flaccid;
- Thinner outer wall shrink and the curvature of the thicker inner wall reduces; then the stomata closes;

36. a) External intercostals muscles contract; internal intercostals muscle relax; Rib cage move outwards; and upwards; Diaphragm muscles contract; diaphragm flatten; Volume in thoracic cavity increases; pressure reduces; Atmospheric air enters the lungs; lungs inflate;
- b) Guard cells have chloroplast; which photosynthesis in the presence of light, to form sugar; the osmotic pressure of guard cell increases; water move from neighboring cells into guard cells; by osmosis. Guard cells become turgid; inner walls of guard cells being thicker than outer walls. Causes the outer wall to stretch more resulting in guard cells budging outwards, stoma opens

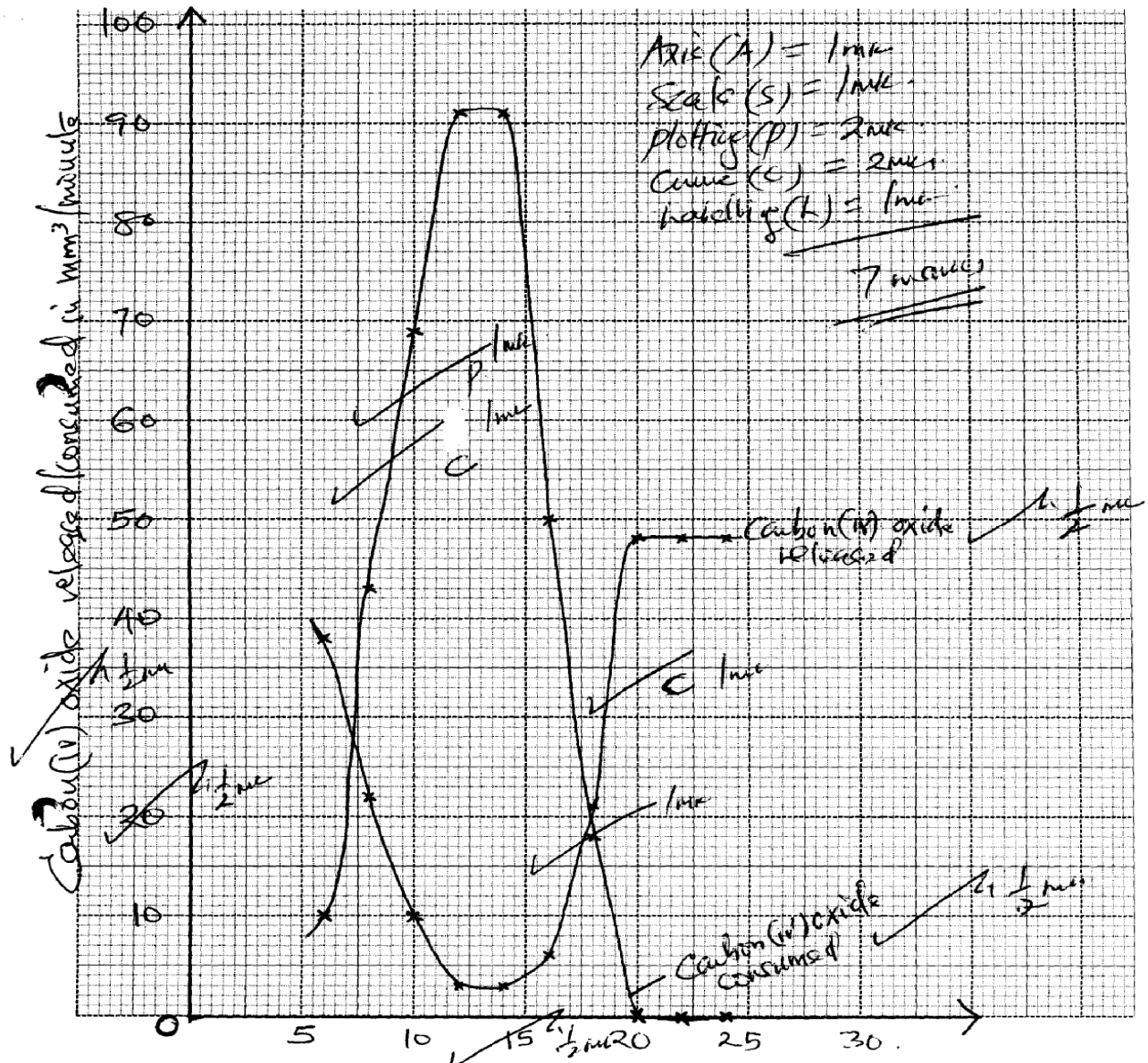

37. (a)
- b)
 - i) Photosynthesis;
 - ii) Respiration
 - c)
 - i) Rapid increase in amount of carbon (iv) Oxide consumed; As time increase amount of light increases', thus increasing rate of photosynthesis
 - ii) No carbon (iv) Oxide consumed, No light hence no photosynthesis
 - d) Low amount of carbon (iv) oxide released, carbon (iv) Oxide consumed for photosynthesis; respiration rate very low
 - e)
 - i) Point when rate of photosynthesis equals rate of respiration
 - ii) At 18 hrs
 - f) It denatures enzymes/ stops photosynthesis; hence consumption of carbon (iv) Oxide

7. Gaseous exchange in (a) plants (b animals)

1. (a) Gaseous exchange is the movement of gases across a respiratory surface; while respiration is the biochemical breakdown of food molecules to produce energy (and carbon IV oxide);
(b) Ethanol/Alcohol;
Carbon (IV) oxide; and energy; (any two)
2. (a) Glycolysis;
Krebs cycle;
(b) Krebs cycle; because oxygen is used to oxidize acid to water, Carbon (IV) Oxide and energy;
3. a) anaerobic respiration/fermentation;
b) -baking of bread
-brewing industry
4. Carbon (IV) oxide produced in respiration is utilized in photosynthesis; oxygen produced in photosynthesis is used in respiration;
5. a) Amount of oxygen required to get rid of lactic acid that accumulates in the body tissues when oxygen available is lower than the demand
b) Energy/A.T.P/ Lactic acid
6. (a) Germinating seeds respired using oxygen in the conical flask and produced CO₂, which was absorbed by the sodium hydroxide solution. A partial vacuum was created in the conical flask. The atmospheric pressure being higher pushes the water down to A and upto B.

- (b) $RQ = \frac{\text{Vol of CO}_2 \text{ produced}}{\text{Vol. of O}_2 \text{ used}} = \frac{102}{145} = 0.70$;
- (c) Lipids;
7. (a)
 - Complete oxidation of lipids require a lot of oxygen;
 - Lipids are insoluble in water hence difficult to transport in the body
 - Complete oxidation of lipids take a longer time
 (b) Maltose
 Lactose
8. a) i) Cytoplasm
 ii) Pyruvic acid
 b) Pyruvic acid is broken down; into ethanol and CO₂
9. a) $RQ = \frac{\text{CO}_2 \text{ produced}}{\text{O}_2 \text{ consumed}} = \frac{5}{6}$; = 0.83;
 b) Protein;
10. Bacteria, bacteria/ Symptoms
 - Prolonged coughing and vomiting
 - Convulsions and coma
 - Conjunctival haemorrhage
 - Severe bronchopneumonia
 Causative agents
 Symptoms
11. - Lowers saturation deficit by trapping H₂O moisture;
 - Protects direct sunlight to the stomatal pore;
12. They form depressions such that when wind blows it does not carry away water molecules.
13. - Increase rate of respiration
 - Speeds up the heart beat rate
14. A rat has a large surface area to volume ratio thus loses a lot of energy on form of heat therefore eats a lot to replace the lost energy;
15. a) Glucose \longrightarrow water + carbon(iv) oxide + energy/210kj
 Or
 $C_6H_{12}O_6 \longrightarrow H_2O + CO_2 + \text{ATP (energy) (mark as a whole) 1mk}$
16. Insoluble hence not easily transported to respiratory sites;
 - They require more oxygen to be oxidized;
17. - Making of beer/Brewing/Ethanol/alcohol;
 - Baking industry/Raising of the dough:
18. (a) Respiration – Chemical breakdown of food to release energy. ✓
 Respiratory surface – Surface across which respiratory gases exchange.

- (b) Circulatory system transports the respiratory gases to and from tissues; hence maintains steep concentration gradient around the respiratory surface;
19. - Not every soluble/not readily soluble therefore not easily transported to the site of respiration;
- A lot of oxygen is required to oxidize one gram of fat/liquid than one gram of glucose;
20. a) $RQ = \frac{\text{Volume of CO}_2 \text{ given out}}{\text{Volume of O}_2 \text{ used}} = \frac{102}{145} = 0.70$;
b) Fats/ oil/ lipid;
Reason: RQ for lipids/ fats/ oils is always less than 0.8; more oxygen is used than carbon IV produced;
21. (a) Boiling
(b) becomes milky/cloudy /precipitate.
(c) Yeast produces enzyme amylase which catalyze breakdown of glucose anerossiccally into energy (heat)
CO₂ and Ethanol
CO₂ makes lime water to become cloudy
(d) High temperature donators enzymes, reduces/stops respiration/stops the reaction.

8. Excretion and homeostasis

1. i) Ammonia is highly soluble in water and requires a lot of water for excretion hence assists in the removal of excess ammonia;
ii) All the glucose is reabsorbed at the proximal convoluted tubule;
2. (a) – Excretion;
- Osmo-regulation;
(b) – Glucose
- Amino acids;
(c) – Nephritis;
- kidney stones /Gall stones;
- Hepatitis A and B;
3. (a) Extra long loop of henle; Have fewer and smaller glomeruli;
(b) Salty food increased the salt concentration in blood; Blood becomes hypertonic to kidney tubules; more water is reabsorbed from kidney tubules; hypertonic urine is thus produced;
4. (a) Glucose;
(b) The person was a sufferer of diabetes mellitus;
(c) Pancrease;
5. a) i)insulin;
ii) Diabetes mellitus;
b) Diuresis is a condition which is characterised by production of large volumes of dilute urine;
6. i) urea;
ii) Triethylamine;
iii) Ammonia;
7. a) i) Fresh water; reject water
ii) Desert/ Arid areas; reject land

- b) Reduces blood flow to the skin as more blood is stored in the spleen, reducing heat loss through the skin;
- 8.
 - a) Ultra filtration;
 - b) Selective reabsorption;
 - c) Proteins have large molecular weights hence not ultrafiltrated;
- 9. Produces sebum to keep hair and epidermis supple and water proof; and protect skin against bacteria (through antiseptic substances);
- 10.
 - a) Sweat produced does not evaporate due to high humidity;
 - b) Body does not cool hence more sweat is produced leading to accumulation;
- 11. Diabetes mellitus
 - Caused by failure of the pancreas to secrete enough insulin;
 - High glucose concentration in the blood than normal;Diabetes insipidus
 - Inability of the pituitary gland to secrete anti-duretic hormone;
 - High concentration of solutes in blood ;
- 12. Two processes through which plants excrete metabolic wastes:-
 - Gaseous exchange;
 - Transpiration;
 - Shading leaves;
 - Production of resins and gums;
 - Storage of wastes in seeds/bark/fruits;
- 13. Has got long loop of henle in order to maximize water reabsorption thus conserving it;
- 14.
 - i) urea;
 - ii) Triethylamine;
 - iii) Ammonia;
- 15.
 - (a) i) Fresh water; reject water
 - ii) Desert/ Arid areas; reject land
 - b) Reduces blood flow to the skin as more blood is stored in the spleen, reducing heat loss through the skin;
- 16.
 - a) Ultrafiltration;
 - b) Selective reabsorption;
 - c) Proteins have large molecular weights hence not ultrafiltrated
- 17. Produces sebum to keep hair and epidermis supple and water proof; and protect skin against bacteria (through antiseptic substances);
- 18.
 - a) Sweat produced does not evaporate due to high humidity
 - b) Body does not cool hence more sweat is produced leading to accumulation
- 19.

Diabetes mellitus	Diabetes insipidus
-Caused by failure of the pancreas to secrete enough insulin -High glucose concentration in the	-Inability of the pituitary gland to secrete anti-duretic hormone -High concentration of solutes in blood

blood than normal - Caused by failure of the pancreas to secrete enough insulin - High glucose concentration in the blood than normal	Inability of the pituitary gland to secrete anti-duretic hormone High concentration of solutes in blood
---	--

20. Two processes through which plants excrete metabolic wastes:-
 -Gaseous exchange
 -Transpiration
 -Shading leaves
 -Production of resins and gums
 -Storage of wastes in seeds/bark/fruits
21. a) A – medulla; B – Cortex;
 b) Cortex;
22. a) Enhances more reabsorption of water; leading production little but conc urine;
 b) Reabsorption of water; Na⁺/CL⁻ ions;
23. a) Aldosterone;
 b) Loop of Henle;
 c) Positive feed back;
24. - Reabsorption of unuseful substances in the kidney;
 - Absorption of digested food from the ileum;
 - Removal of metabolic waste products from kidney;
25. a) A D H / Vasopression;
 b) Pituitary gland;
 c) Diabetes Inspidus;
26. a) - Afferent vessels are wider than effereal vessels;
 - Presence of pores on capillary and Glomerula membrane;
 - Highly coiled narrow capillaries to reduce speed of flow of blood and increase ;
 pressure
27. a) Arid/ semi arid areas
 b) Ammonia
 c)i) Contractile vacuole
 Malpighian tubules
28. - Deamination
 - Detoxification
 - Breakdown of haemoglobin
29. a)Deamination;
 b)-Removal of excess amino acids;
 -Availing of energy in the body;
 -Formation of glycogen /fats for storage; (award any one)
30. a)diabetes insipidus;
 b)antidiusetic hormones (ADH);

31. a) large quantities of dilute urine;
b) Small quantities of concentrated urine ;(renal failure if habitual)
c) Production of urine containing glucose/sugar;
32. (a) Excretion — Separation and elimination of waste products of metabolism from bodies of living organisms:
Egestion; Removal of undigested materials from food vacuoles/alimentary canals of animals:
(b) Removes waste products metabolism to create/pro'. idea suitable internal environment for best working of cells
33. (a) N – desert/arid/semi arid;
(b) Small sized glomeruli; to reduce ultra filtration longer loop of henle; to increase reabsorption of water – conservation of water.
N.B – Reject 12(b) if 12 (a) is wrong.
34. (a) – Organisms whose body temperature varies with the environmental temperature; ✓
(b) – Reptilia - rej. Reptile;
- amphibia - rej. Amphibians;
35. Glomerulus;
Adaptations of part R
- Coiled to increase the surface area for re-absorption of some glomerular filtrate
- Presence of numerous Mitochondria to promote active transport of glucose, amino acids
- covered by dense network of blood capillary for absorption of useful glomerular filtrate
36. Internal environment is the immediate surrounding of the body cells while external environment is the immediate surrounding of the organism
37.
• Radiation;
• Conduction;
• Convection;
• Evaporation ;
38. a) A – capsular space/ Bowmans capsule;
B – Descending wing of loop of Henle;
D – Glomerula
b) Urea;
39. Ovary; accept ovules
Anthers;
40. a) Detoxification;
b) Liver;
c) Prevents ammonia from accumulating to toxic levels; which would affect body functions;
d) Urea;
e) Excess amino acids are broken down to form amino group; which is combined with hydrogen atom to form ammonia;
f) It is transported to the kidney; through the renal artery where it is excreted

41. a) platelets exposed to air rupture on damage tissues to release thromboplastin/(enzyme) /thrombokinase; Thromboplastin neutralizes heparin; and activates prothrombin to thrombin; thrombin activates the conversion of fibrinogen to fibrin; which forms meshwork of fibres on the bruised surface;
b) blood clotting is the conversion of soluble blood protein into a mass of tangled threads of insoluble protein; while haemogglutination is the clumping together of red blood cells;
c) haemophilia;
42. a) i) glucose is completely reabsorbed at proximal convoluted tubule back to blood stream;
ii) Protein has molecules hence not ultrafiltered (from glomerulus) to proximal convoluted tubule);
b) Create a steep diffusion gradient; hence higher rate of reabsorption of useful Substances-glucose/amino acids/sodium and chloride ions from the nephron tubules back to the blood stream;
c) -antidiuretic hormone;
-Aldosterone;
d) nephritis; kidney stones
43. (a) Nephron;
(b) (i) D = Afferent arteriole;
M = Efferent vessel;
(ii) Q = Aldosterone ; G - ADH/ vasopressin.
(c) Red blood cells/white blood cells/ plasma proteins;
(d) This shows that reducing sugar (glucose) was present in urine; the person is likely to be suffering from Diabetes mellitus;
44. (b) (i) Blood sugar level increased as a result of the glucose being absorbed in the ileum; by diffusion / or active transport;
(ii) – The blood sugar level dropped as a result of the conversion of glucose to glycogen; (and fats) by influence of insulin;
- There was also an increased rate of respiration reducing the blood sugar level;
(c) 90 mg/100ml of blood;
(d) Person B has a defect in the pancreas; He did not produce enough insulin to control the blood sugar level;
(e) By administration of insulin;
(f) - A constant level of blood sugar ensures optimum levels of metabolism;
- High level will increase the osmotic pressure and that affect metabolism;
- Low levels reduce energy supply in the body tissues and affect metabolism;
(g) - Glucose is used for respiration;
- Glucose was lost in urine;
45. a) Axis
Scale
Plotting
- b) i) The rate increases with time;
Because a lot of acid been drunk;
Very little ADH or No ADH produced yet;
No reabsorption taking place;
- ii) The rate remain constant

Pituitary not stimulated to produce ADH
 Nephrons, less permeable
 No water being reabsorbed back to blood;

- iii) The rate reduces with time;
 Little water remaining in blood; due to a lot of water lost through urine;
 No water being taken

c) ADH: Adosterone

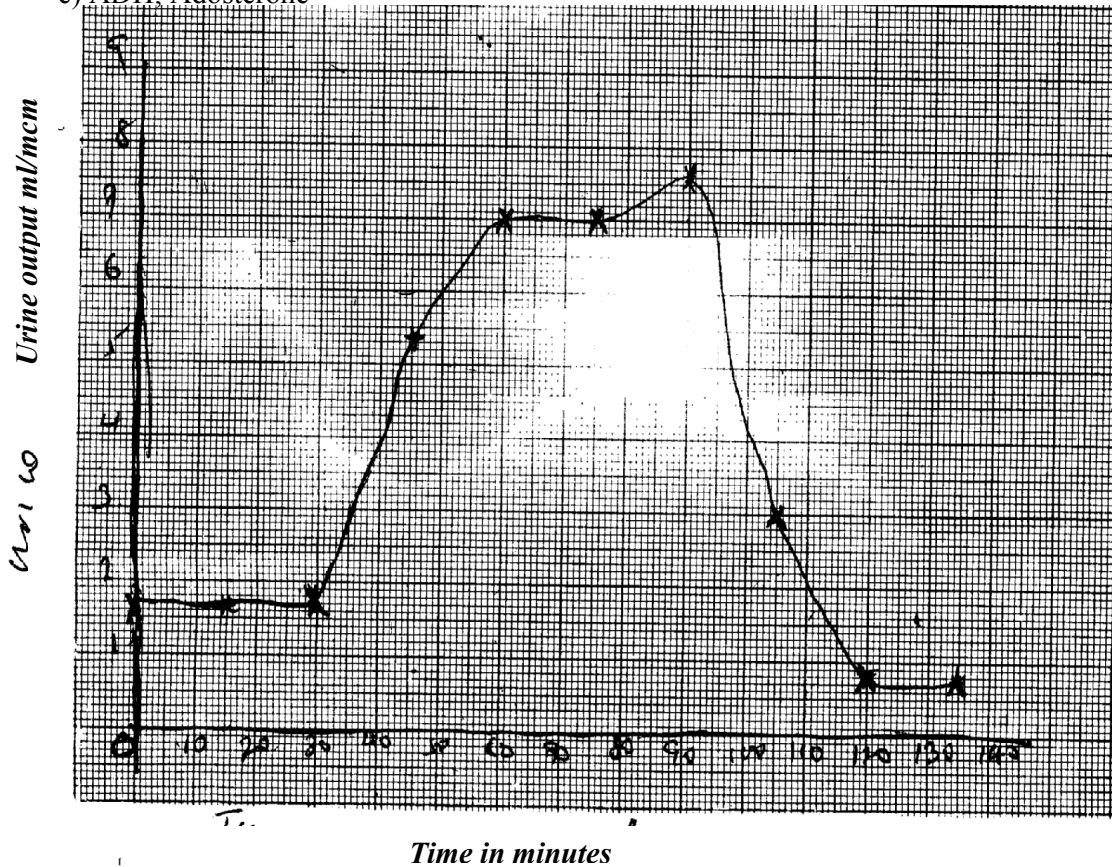

46. (a) Explain how urea is formed in the human body:
 - Excess amino acids are deaminated and the converted into urea in the liver
 (b) Describe the path taken by urea from the organ where it is formed until it leaves the human body
 - Urea from the liver is carried through hepatic vein into post/in prior vena cava; right auricle, right ventricle; pulmonary artery into lungs; Pulmonary vein, left auricle; left ventricle; aorta renal artery; glomerulus's; into Bowman's capsule; kidney tubules ascending and descending); collecting tubule ureter; into urinary bladder, urethra and out of the body in the form of urine.
47. a) B- Bowman's capsule
 C- Loop of Henle
 D- Distal convoluted tubule
 b)
 - have numerous/ many microvilli; to increase surface area for reabsorption

- coded to slow down filtrate for reabsorption
 - have many/ numerous mitochondria to provide energy for reabsorption
 - c) - Active transport
 - d) Afferent arteriole is wider than the efferent arteriole
-
- (d) Storage of vitamins (e.g. vitamin A, B2 & D)
 - Storage of mineral salts (e.g. Potassium and Iron)
 - Storage of Blood
 - Manufacture of R.B.C
 - Manufacture of plasma proteins (Albumen, fibrinogen & Globulin)
 - Regulation of amino acids (deamination)
 - Regulation of lipids
 - Regulation of body temperature (thermoregulation)
 - Destruction of worn out R.B.C
 - Elimination of sex cells
-
48. a) X- Thromboplastin
Y- Fibrin
Z-- Thrombin
- b) Promotes wound healing; stops further loss of blood/ bleeding; prevents entry of pathogens/ injection
- c) Blood contain leparin/ anti clotting factor eight; that inhibits blood coagulation
-
49. a) Response of an endotherm to heat gain
- i) Subcutaneous of fat little/ localized: to encourage heat loss/ not to impede heat loss
 - ii) Hair is lowered/ lies flat; by relaxation of erector pilli muscles; insulator reduced/ little air trapped; heat readily lost (by radiation and convector)
 - iii) Sweating/ panting occur
Evaporation of water absorbs latent heat of vaporization; leaving a cooling effect
 - iv) Cutaneous/ superficial blood vessels dilate;
Blood flows near skin surface facilitating heat loss
 - v) Metabolic rate falls/ BMR falls
Less heat generated to avoid overheating
- b) Response of Endotherm to heat loss
- i) Subcutaneous/ Adipose fat insulates; facilitating heat conservation
 - ii) Hair raised/ erects; by contraction of erector pili muscle; Insulator increased/ traps air; facilitating heat conservation
 - iii) Cutaneous/ superficial blood vessel vasoconstrict blood flows deep in the dermis; conserving heat
 - iv) Sweating/ panting stops; little heat is conserved
 - v) Extra heat is produced; by increase in metabolic rate of liver/ muscles/ shivering/ goose pimples/ animals become more active
-
50. (a) (i) Efférent arteriole/vessel; (I mark)
(ii) Loop of Henle: (Rj. Wrong spelling) (I mark)
- (b) (i) Small sized; Few; (2mrks)
(ii) Large sized: Many: (2marks)
- (c) (i) Glucose:
(ii) Diabetes mellitus: (Rej; wrong spelling)

51. High body temperature above normal: sweat glands: produce sweat: water in the sweat evaporates/ sweat evaporates: absorbing latent heat of vaporization produces a cooling effect. Hairs lie flat; due to relaxation of erector pilli muscles: no/little air is trapped: [fins increased heat loss from the body; Blood arterioles/vessels; vasodilate/dilates: more blood floss to the skin hence more heat is dispersed by radiation and convection: when the body temperature is low below normal; sweat glands produce less/no sweat: no latent heat is absorbed/more heat is retained in the body; The hairs stand upright/erect: to trap air between them: that insulates the body against at loss; more heat is retained in the body; Blood vessels/arterioles constrict/vasoconstrict: less blood flows to the skin: reduces heat loss/ more heat is retained in the body; Subcutaneous fat/ adipose [issue; beneath the skin insulates the body against heat loss: more heat is retained in the body: 22 marks

9. Ecology

1. a) Capture –recapture method;
b) Calculate the population of grasshoppers using the above data

$$\frac{FM \times SC}{MR} = \frac{36 \times 45}{4} = 405;$$
2. a) Help to breakdown dead organic matter hence reducing bulk; in the recycling of Nutrients;
b) Regulate the predator – prey population;
3. a) Grass _____ grasshoppers _____ birds;
b) Not all the energy is transferred from one trophic level to another; some is lost as heat, some is used up during metabolism and some is lost when organisms die and decay;
4. Autecology is the study of population / study of members of a species;
Biomass is the quantity of matter of a given type of organisms at a given trophic level;
Or the dry weight of an organism;
5. – Availability / adequate food supply ;
- Absence of predations ;
- Absence of disease; (mark the first two pts
6. (a) Habitat – physical location with asset of condition where an organism lives; while niche is the exact place where an organism occupy and its role in the habitat;
(b) Producers have a greater biomass than primary consumers since they start the food chain.
Inter-trophic energy losses occur in form of heat;
(c) It is non-toxic; It's organism specific;
7. Reduce oxygen supply and hence suffocation and death of plants and animals, clog respiratory surfaces (gills and stomata) leading to death;
8. (a) Food web;
(b) Three;
(c) Sun
9. a) Microscopic plants- mosquito larvae- small fish- large fish- crocodiles
b) Large fish;

10. a) Owl is nocturnal , white mice are easily seen and predated on, black mice camouflaged/ not easily predated on;
 b) (Theory of) Natural selection;

11. a) Capture recapture method

b) i)
$$P = \frac{FM \times SC}{MR}$$

$$= \frac{725 \times 974}{139}$$

$$= 5080;$$
 Where FM – First marked
 SC – Second recapture
 MR – Marked recapture
 P - Population

- ii) – No fish moves in or out of the area between counts ;
 - The marked fish mix freely with other fish populations;
 - Marking does not expose the fish to predation ;
 - No variation in population size ;

12. D → A → C → B

- (b) - Correct label;
 - A,B same size;
 - C-largest;
 - D- smallest;

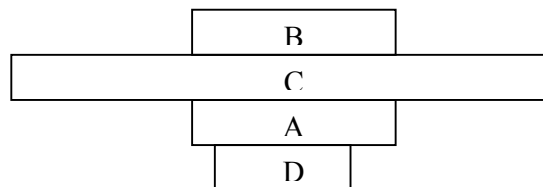

13. - Protects delicate internal parts from mage;
 - prevents excess loss of water (desiccating);
 - provides surfaces for attachment of body muscles / organs;

14. a) Grass → Grasshopper → Guinea Fowl;
 Grass → Termites → Guinea Fowl;
 b) - Leopards will decrease;
 - Gazelles will also decrease;
 c) Grass;

15. Population — all members of one species occupying a particular habitat at a given time;
 Community — all organisms belonging to different species that interact in the same habitat;

16. - lay down two ropes parallel to each other a meter apart; count the number of shrubs between the two ropes at marked points; and record the number; repeat the process several times;
 Obtain average number; calculate area of the belt transect.

17. a)
$$\text{Population} = \frac{FM \times SC}{Mr}$$

$$P = \frac{10 \times 50}{4} = \frac{500}{4}$$

= 125;

- b) No entry or exit of fish;
Tags did not influence the general behavior of fish
- 18. - they decompose organisms; aid in nutrient circulation
- 19. i) Accumulation of CO₂ in the atom
ii) Increase in environmental temperature
- Erratic weather changes
- 20. - Enzymes amylase digests starch to maltose
- Mucus lubricates food
- 21. Due to (stiff) competition for available resources which leads to elimination/exclusion;
- 22. a)feeding level;
b)quaternary consumer;
c)sun/source of energy;
- 23. Adaptive radiation/divergent evolution;
- 24. i)crab pop= $\frac{\text{number marked in 1st catch} \times \text{total no. in 2nd catch}}{\text{Number marked(recaptured)in second catch.}}$
= $\frac{400 \times 360}{90}$
=1600;
ii) Capture mark release recapture/
Capture-recapture /capture release /recapture;
- 25. (a) Suck small crawling insects (from tree trunks):
(b) Catching (flying) insects in grass:
- 26. (a) Used for the collection of flying specimens such as butterflies;
(b) Used for sucking small insects from barks of trees and under stones; ✓
(c) Used for trapping crawling insects such as termites; ✓
- 27. 1. Competition; ✓
2. Emigration; ✓
3. Predation; ✓
4. Parasitism; ✓
- 28. (a) Biotic and abiotic factors (2x ½ =1mk)
(b) - Faecal analysis
- Type of dentition type of beak (2 x1=2mks)
- 29. X – denitrifying bacteria/
Y – Animals/ herbivores; accept primary consumers
Z – Nitrogen fixing bacteria (in soil) accept Azotobacter
- 30. a) Check graph

- Labelling axes;;
- Scale
- Plotting;
- Joining (smooth contineas);
- Identifying the graph;

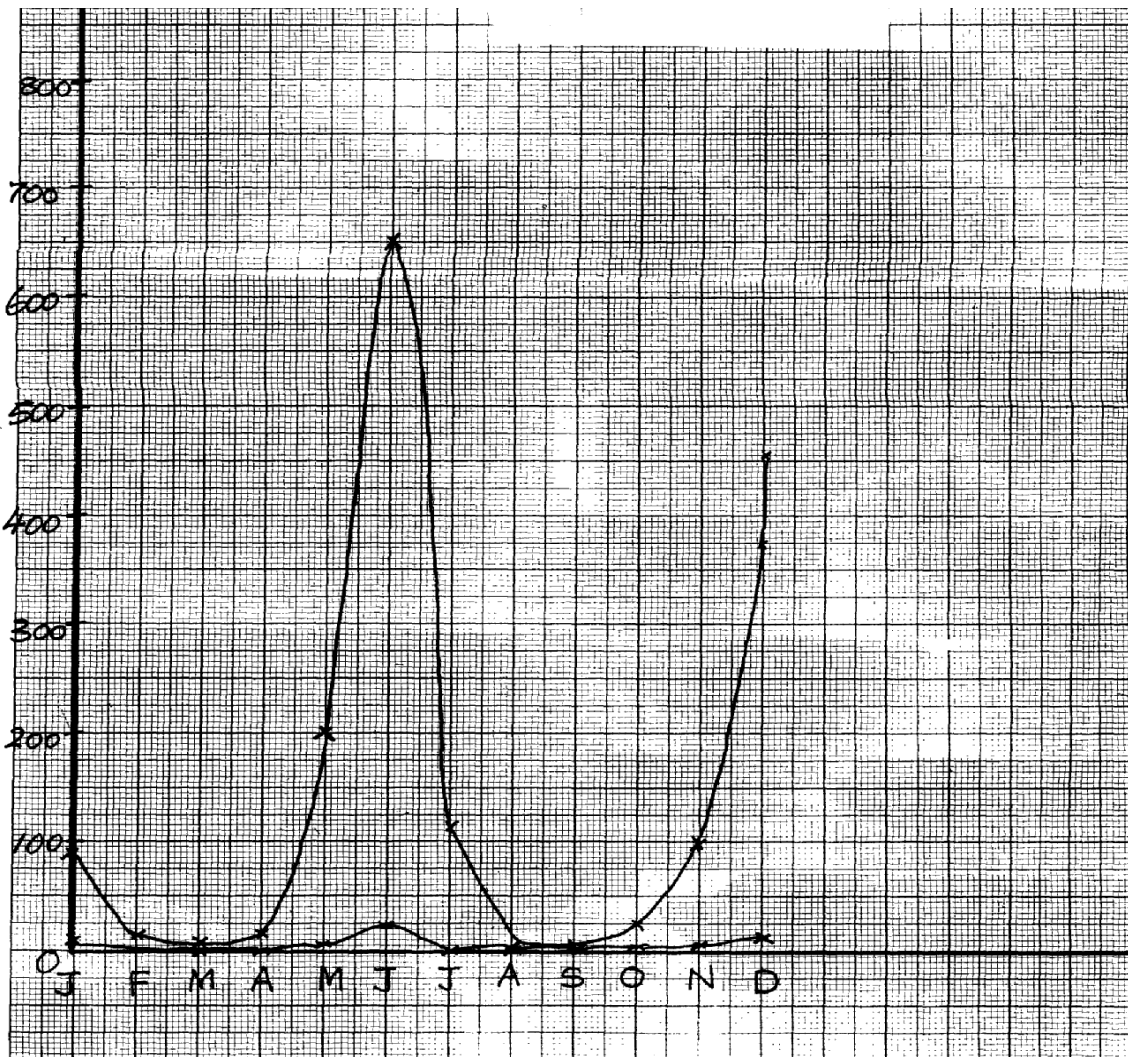

- b) i) The population of locusts increase with increase in that the amount of rainfall;
ii) – Increased amount of food;

- Improve breeding conditions;
 - c) - The population of both decreases
- Less food availability for locusts and hence crows;
 - d) i) Quadrat method;
ii) total counts
 - e) i) locusts ____ primary consumers;
Crows _____ secondary consumers;
ii) Grass ____ Locusts _____ crows;
 - f) - Grass would increase;
- Crows would reduce;
 - g) Wild animals are browsers hence obtain food while cows are grazers hence lack grass
 - h) Biomass is the total dry weight of organisms at a particular trophic level;
31. (a) (i) Antelope A;
(ii) Reason- Rate of multiplication /reproduction is higher in species A than B;
- (b) (i) Sigmoid curve /ogive/s-shaped curve;
Accept any one correct
- (ii) PQ- Lag phase /slow growth phase; QR- Exponential/log / rapid growth phase;
RS – Deceleration phase ST- Stationary/constant growth phase;
- (c) (i) Q and R
Marked with rapid population growth rate; many mature reproducing organisms/individuals/antelopes;
Absence of environmental resistance;
- (ii) S and T - Growth rate stagnant/birth rate equals to death rate; the ecosystem has attained its carrying capacity/environmental resistance (density dependent) have set-in;
- (d) (i) Interspecific;
(ii) Thin and tall; yellow/pale green; low yield
- (e) By occupying different (ecological) niches;
- (f) Move swiftly to escape predators; camouflage to avoid noticed by predators; Eyes on the side of the head to give them a wide field of view enabling them to keep track of their enemies;
- (g) Capture –recapture method,; direct count,
Aerial photography
32. Water- The availability of adequate amounts of water lead to plant growth which provides food for animals. In aquatic environment, water is a medium in which gametes are released thus lead to continuity in procreation.
Temperature- Influences the rate of enzyme catalyzed reactions. Therefore, it exerts an influence on almost all activities of plants and animals such as respiration, photosynthesis, growth, transport e.t.c.
Light-Is necessary in plants for photosynthesis as it influences flowering of a wide variety of plants, affecting opening and closing of stomata, affect the rate of transpiration.
Salinity- Is the salt content of water. It varies in aquatic habitat. Fresh water organisms suffer the risk of losing water.
Humidity – Determines the amount of water loss from a bodies animals and organs of plants; high humidity means less evaporation; and low humidity means high rate of evaporation and transpirations;
pH – It determines if water habitat is acidic or alkaline; PH has a great influence on physiological function of organisms affects enzyme concern reactions since enzymes operate within a narrow pH ranges

Wind- Wind cause physical damage to plants; increase rate of transpiration as air blows away; causes migration of insects; wind carrying gases may cause acid rain in a region; wind is an agent of pollination and dispersal;

33. (a)

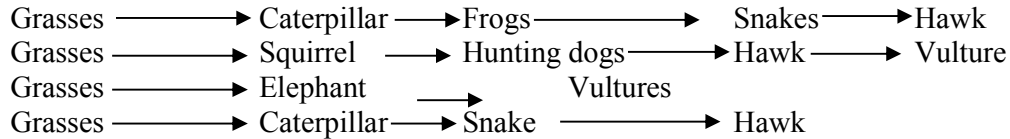

(b) Pyramid of numbers.

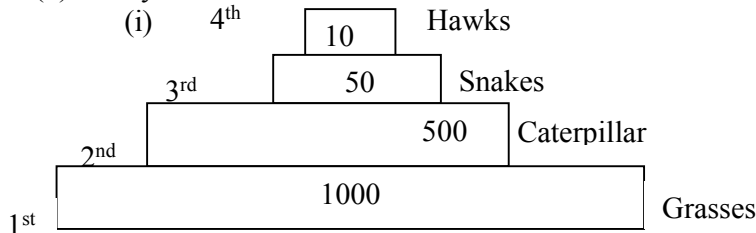

Or:

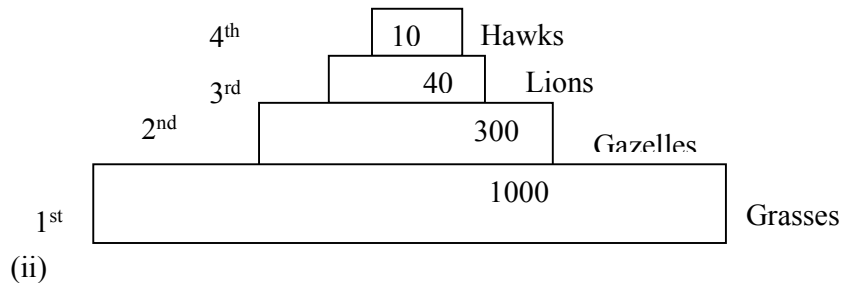

(c) Effects of removing the hunting dogs.

- Increase in number of gazelles and squirrels due to reduced predation leading to increased pressure upon the grass;

(d) During transfer of energy at each feeding level, some amount of energy in form of heat is lost only about 10% would be transferred from the grains to steers and out of the 10% about 1 kg would be transferred to man. The rest would be lost as heat or ingestible material.

34. a) i) Slugs; mice;/ Amphids/ caterpillar

ii) Primary consumers;

b) i) plants _____ mice _____ snakes _____ Hawks;

Plants _____ Caterpillar _____ insectivorous birds _____ hawks

c) Plants ; _____ directly obtain energy from the sun

Hawks – Loss of energy in form of heat; through process of respiratal/ defaecation/ excretion

35. a) A lot of food causes population increase due to high rate of reproduction and immigration resulting in competition for food/ death/ emigration; reducing population; little food leads to competition; leading to emigration/ death; reducing population

- b) Energy from the sun is trapped by green plants; during photosynthesis; producing chemical energy/ carbohydrates/ food
Green plants are producers/ 1st trophic level; Green plants are eaten by herbivores which are primary consumers/ occupy the second trophic level, when plants die and animals die organisms die; saprophytic fungi/ bacteria/ micro organisms feed on them; thus decomposing them into smaller/ simpler substances/ they are decomposers/ detritivores; At all levels some energy is lost; through respiration
36. a) A- Ovary
B- Oviduct/ fallopian tube
C- Uterus/ uterine wall
D- Cervix
b) Produce ova
Produce female hormones/ Estrogen and progesterone
c) - Highly vascularized to supply nutrients to foetus/ drain away excretory wastes
- Inner wall lined with Endometrium for implantation of fertilized egg/ zygote
- Muscular for peristalsis to expel menses during menstruation/ parturition
- Great capacity to expand during gestation to accommodate developing foetus
d) - copulation/ Achieve orgasm in Human male followed by ejaculation
- birth canal
37. a) use the capture-recapture method; capture the grass hoppers; count; and mark using permanent ink; record; releases; and allow time(1-24hrs);recapture and count the marked and unmarked;
Total population is equal to the number marked and unmarked grasshoppers in the second sample X number of marked grasshoppers in the first sample ; divided by number of grasshoppers marked in the second sample that were recaptured;
Acc P= $\frac{FM \times SC}{MR}$
where FM-1st captured
SC-2nd capture(marked and unmarked
MR-marked recaptured
(rej. ½ mark i.e. 10/2=5) acc specified distance apart e.g. 3m apart
b. run two ropes parallel to each other a meter apart; counts of shrub are made between the two ropes at marked points/whole belt (and recorded);report the process severally(at least 3 times);calculate shrub area of the belt transect; calculate shrub population for whole area;
Rej all shrubs counted
NB shrub pop=average shrubs per transect x total area of grassland
Average area of belt transect (max 3)
38. (a) (i) Phytoplanktons:
(ii) Hawk; and water snake:
(b) - Decrease in phytoplanktons:
- Increase in population of small fish:
(c) Hawk;- Top predator amount of energy decreases in successive trophic level/energy is lost through respiration; undigested/unconverted food:
(d) Residue is poisonous to man;
-Kill non- targeted organism / Beneficial organisms:
-Remains for along time in the ecosystem / pollutes environment:
(e) (i) Causes decomposition/Recycling of nutrients:

- (ii) Root nodules: have bacterial / Rhizobium sp: to convert free nitrogen: into nitrates in the soil;
 - (f) Capture - recapture: capture release recaptures:
 - (g) Manufacture food: (OWTTE) to be used by themselves: and all other organisms in the ecosystem (awls)
39. Broad/ wide lamina: to Provide a large surface area to trap maximum sunlight or photosynthesis;
- Thin lamina; to reduce the distance covered b\ light and carbon (iv) oxide: to reach the photosynthetic cells/ palisade cells;
 - Cuticle; is transparent to allow light reach photosynthetic cells:
 - Waterproof climatic cuticle: to reduce water loss/Transpiration:
 - Numerous stomata: efficient gaseous exchange: palisade (mesophyll) cells: have numerous chloroplasts: for maximum photosynthesis: spongy mesophyll cells: are irregular in shape creating large air spaces between: for efficient /free circulating air; Lear veins; have x 1cm 1r transport of water and mineral salts: and phloem for transport of manufactured food;
 - Leaf mosaic: to maximum trapping of sunlight for photosynthesis:
 - Guard cells: to control opening and closing stomata: Guard cells have chloroplasts for photosynthesis:

10. Reproduction in (a) plants (b) animals

1. a) i) integuments ;
ii) Primary endosperm nucleus;
b) This is fruit development without fertilization;
2. - Secretion of progesterone and oestrogen;
- Controls exchange of material between maternal and foetal blood;
- Prevents entry of pathogens from the maternal to the foetal circulatory system;
3. – Sexual intercourse with infected persons;
- Transfusion with infected blood;
- sharing contaminated needles;
- Infected mother to child through breastfeeding;
- Contact with infected blood/body fluids through cuts or wounds; (mark the first 3 points)
4. (a) Par thenocapy;
(b) Ethylene;
(c) Promoted differentiation of adult features;
5. – Site for fertilization;
- Conducts on a from ovary to the uterus;
6. (a) X – Polar nuclei; Y – Egg cell;
(b) – Results to variation; that makes the plant to be adapted for survival;
7. (a) Chiasma; reject – chiasmata
(b) (i) Provide a chance for the exchange of genes (along the portion of chromosome);
(ii) Meiosis;

8. (a) When they can freely interbreed to produce fertile/viable offspring;
(b) Is the occurrence of two distinct reproductive forms in the life cycle of an organism; the diploid sporophyte phase and the haploid gametophyte phase;
9. (a) Acquired characteristics are not inherited/inherited characteristics are found in reproductive cells only;
(b) Mutations bring about variation which when advantageous can be passed on from one generation to the next; and this can lead to emergence of new species;
10. (a) Gaseous exchange; means through which foetus get nutrients from the mother; offers a means for elimination of wastes by the foetus; supplies antibodies to the embryo from the mother; secretes progesterone hormone that maintains pregnancy;
(b) because testosterone is transported through the blood
11. – Protandry
- Protogyny;
- Self sterility/incompatibility
12. – Ability to pollinate;
- Ability to photosynthesis;
- Ability to disperse seeds/fruits;
- Ability to absorb water and mineral salts from the soil;
13. (a) Fusion of one male nucleus with an egg cell to form a diploid zygote; and fusion of the other male nucleus with two polar nuclei to form triploid endosperm;
(b) – Are brightly coloured to attract insects
- Have seed coat that is resistant to digestive enzymes
- Have hooks for attachment to passing animals
- Are fleshy/succulent to attract insects
14. a) Oxytocin;
b) Progesterones;
on different individual plants;
-some plants are self-sterile in their pollen grains transferred to stigmas in the same plant fail to germinate;
-in some plants stamens and carpel on the same plant mature at different times;
-in many plants the stigmas are located higher than the anthers;
15. -some plants are dioecious which means that staminate and distillate flowers are borne
16. a) A – Has umbilical vein and artery to supply foetus with nutrients and removal of waste products; ✓
B – Protects embryo from shock/regulate temp. of developing embryo/ suspends and supports embryo;
b) Foetus head is turned towards the cervix; ✓
c) To supplement iron synthesized by the mother since it (iron) is needed for haemoglobin formation in the foetus; ✓
17. i) Marginal; ✓
ii) Free central; ✓

18. a) Cypselia b) Animal
19. i) Production of the hormones progesterone and oestrogen continues;
 ii) These hormones inhibit the production of follicles;
 Stimulating hormone (FSH) and luteinising hormone (LH);
 iii) This inhibits the maturation of more follicles;
20. a) It brings about useful variations which make the offspring better adapted for survival
 b) i) 33;
 ii) 11;
21. a) A – Antipodal cells; B - Embryo sac; D- Synergid ;
 b) Double fertilization
22. They cannot freely interbreed to produce a viable /fertile offspring OR- do not have hereditary distinction to interbreed to produce a fertile viable offspring;
23. Adverse temperature , wind/air current, pH, light noise ;
24. (a) (i) Epigynous –a condition where other floral parts arise/positioned above the ovary
 /inferior ovary
 (ii) Staminate flower – Male flower (accept – has stamen only / male parts only);
 (b) Meninges;
25. (a) Yeast ; (b) Budding;
26. – Through breast feeding if mother’s nipple and baby’s mouth have rashes/wounds
 - During delivery;
 - During pregnancy;
27. a) Production of spindle fibres
 b) i) Absorbs light energy; which is used to break down water molecules into O₂ gas and H⁺/ atoms ;
 ii) Glucose;
28. a) Prophase I ; Reject prophase alone
 b) i) There is crossing over of genes that leads to variations;
 ii) Leads to formation of gametes;
 Brings about genetic variation;
 It helps retain a constant diploid chromosomal constitution in a species at fertilization;
29. a) Stamens hanging outside the flower; large anthers loosely attached to flexible filaments;
 Large amounts of small; light and powdery pollen grains to be easily blown by the wind;
 b) Monoecious plants have both male and female flowers borne on separate plants;
30. a) Inability of seeds to germinate despite all the conditions necessary for germination are provided;
 b) Scarification;
 Increase the concentration of hormones which stimulate germination/ increase auxin conc;
 Allow the embryo to mature before planting seeds;
 Remove germination inhibitors;

31. a) Allows the adult to reproduce;
Allows the species to disperse in order to colonize new habitats;
b) Leads to the formation of the larval cuticle;
32. - Hot water kills organisms in the water;
- Reduces oxygen content in the water leading to suffocation;
- Chemicals in the element may lead to entrophication;
33. - Chances of fusion of gametes are low
- Large amounts of gametes are produced leading to wastage
- Changes of survival of the young ones are low since there is lack of parental care
34. - Allow nutrients to pass from mother to Foetus
- Allow diffusion of excretory products from Foetus to mother's blood for excretion
- Produce hormones Oestrogen & Progesterone / that retains pregnancy.
- Prevents passage of foreign particles e.g. pathogens.
35. a) i) prophase I
ii) Chiasmata Formation / cross over
b) _Ovary
- Anthers
36. - Ensures no competition for dispersal;
- Survival of pupa stage;
37.

Mitosis	Meiosis
- Two diploid daughter cells are formed	- Four haploid daughter cells are formed;
- No crossing over	- There is crossing over because of chiasmata; formation;
- Takes place in one cell division	- takes place in two cell division;
- Leads to growth	- leads to gamete formation
- Takes place in somatic cells	- takes place in reproductive cells;
38. Due to (stiff)competition for available resources which leads to elimination/exclusion;
39. i) healing and repair of the uterine wall following menstruation stimulates the pituitary Gland to secrete L.H; (award any one)
ii)-cause ovulation
-changes the remnants of graafian follicle to corpus uteum;
-initiates secretion of progesterone; (award any one.
iii)-accelerates growth and maturity of graafian follicle;
-stimulate the graafian follicle to secrete oestrogen; (award any one.)
40. (a) A - Syncarpous: B- Apocarpous; Rj: Wrong spellings
(b) A fused ovaries B — separate ovaries:
(c) Hinder self pollination? fertilization:
- 41.
- | Sperm | Ovum |
|------------------|--------------------|
| - Spear shaped. | - Spherical shaped |
| - Posses a tail. | - No tail |
| - Has acrosome . | - No acrosome |

- | | |
|------------------------|---------------------------|
| No vitelline membrane. | - Has vitelline membrane. |
|------------------------|---------------------------|
42. (a) anthers; (b) – tube nucleus;
- Generative nucleus;
43. (a) – Metaphase 1; rej. Metaphase.
(b) - Homologous chromosome arranged on the equator;. ✓
- Spindle fibres formed and attached at the centromere of the chromosome;
44. Progesterone;
45. - Seed dormancy allows the plant to escape harsh conditions of the environment
- It also allows time for the seed to disperse;
- Seed dormancy allow time for the seed to fully mature (after ripening period);
46. (i) - A fruit has two scars while a seed has a single scar
- Fruits are covered by epicarp while seeds have seed coats/testa
(ii) Biological control helps to prevent pollution f the environment
47. (a) Site for sperm formation (b) For nourishment of sperm cells /support
48. (a) Ovary; anther (b) Small/light/smooth
49. - Self sterility;
- Dioecious plants;
- Protandry and protogyny;
50. In birds the embryo develops externally. It is totally dependent on food stored in the egg for its nourishment; In mammals the embryo receives nourishment from the mother through the placenta
51. Pollination is the transfer of pollen grains from an anther to a stigma;
Fertilization is the fusion of the nucleus of a male gamete with the nucleus of a female gamete to form a zygote;
52. a) Water dispersal
- Such seeds and fruits enclose air in them to lower their density for buoyancy;
 - They are fibrous/ spongy to lower the density for buoyancy;
 - Have impermeable seed coat or epicarp to prevent water from entering during flotation so as to avoid rotting;
 - The seeds can remain viable while in water and only germinate while on a suitable medium;
- Wind dispersal - They are light; and small; to be easily carried by wind currents due to lower density;
- Have developed extension which create a larger surface area; so as to be kept afloat in wind currents e.g. * Parachute like structures;
* Wing like structures;
- Animal dispersal - Brightly colored to attract animals
-Fleshy to attract animals;
- Some have hook like structures to attach on animals fur
- Self dispersal - They have weak lines on the fruit wall along which they burst open to release seeds, which get scattered. This occurs when temperature changes suddenly
- b)
- The zygote formed when egg nucleus fuses with one male nucleus develops into the embryo of a seed
 - The triploid nucli develops into the primary endosperm of the seed
 - The inner and outer interguments develops into the seed testa

- The ovary wall differentiates into epicarp, mesocarp and endocarp forming a fruit
- The ovule then develops into a seed
- The corolla dries up and withers away
- The calyx may persists shortly as it photosynthesis but afterwards , shrivels, dries and withers away
- The Androecium shrivels,dries and withers away
- The stigma together with the style shrivels, dries and withers away

53. Wind dispersal.

- Parachute of hair, increase surface area to be carried by wind /float
- Wing like structures, increase surface area to be carried by wind /floats.
- Small/light, seed/fruits to be carried by wind have censor mechanism/split open particularly and shaken by wind to throughout the seeds.

Animal dispersal

- Juicy/succulent/fleshy, to attract animals; hooked; to stick on animals bodies and be carried away.
- Hard seed coat; to resists digestive enzymes. Hence come out a long with feaces/dropping of animals.
- Brightly coloured; to attract animals that carry them away.
- Scented; to attract animals that eat and scatter their seeds.

Water dispersal;

- Fibrous fruit wall/mesocarp with air spaces to store air hence make them buoyant/float in water;
- Air floats make them buoyant/float on water.
- Self dispense mechanism
- Fruits dry and crack/open violently along the lines of weakness throwing away the seeds.

54. (a) Pituitary gland

(b) (i) Testosterone

(iii) Follicle stimulating hormone

(v) Leutinising hormone

(c) Sterility/lack of spermatogenesis. Failure of secondary sexual characteristics.

(d) Inhibit production of F.S.H

Inhibit production of L.H

55. (a) I – F.S.H (Follicle stimulating Hormone);

II- Lutenizing Hormone (LH);

III. – Androgen/Testosterone/male Hormone

(b) Progesterone;- brings about protogenetion/development/thickening of uterine wall;

(c) A – Inhibition of L.H

B – Stimulation of L.H

(d) – Growth of hair on the armpit and pubic region; - Development of pimples on the face;

56. (a) Role of spleen in human defense mechanism:-

- Form lymphocytes which ingest pathogens present in the blood;
- Produce antibodies; which neutralizes poisons produced by the pathogens

(b) Ways of controlling HIV spread:

- Testing and transfusing blood free form the HIV
- Avoid sharing of cutting instruments (OWTTE) any two

(c) Meaning of the word Acquired Immuno Deficiency Syndrome:

- Development of lack of immunity system resulting to various chains of infections

(d) Reason for encouraging vaccination prevent/control infection which is better/cheaper than treatment

(e) Is acquired when an individual is infected and naturally produces immunity and recover from the infection

57. Seeds and fruits are adopted to the various methods of dispersal:-

Water dispersed fruits and seeds;

- Mesocarp fruits has air spaces thus light/buoyant to float; therefore carried away by water; seeds are protected from soaking by water proof pericarp / testa;

Animal dispersed fruits/seeds;

Presence of hooks for attachment to animals thus carried away to other places; fruits are also brightly coloured;

-Succulent; aromatic /scented to attract animals; the seed coats are hard and resistant to digestive enzymes; the seeds are therefore dropped away in faeces/droppings'

Self dispersed seeds/fruits/explosive mechanism;

- The dry pods/fruits splits along line of weaknesses/sutures; scattering seeds away from parent plant;

Wind dispersed fruits/seeds;

- censer mechanism; open/split; to disperse the seeds. Perforated capsule is usually loosely attached to stalk / long stalk is swayed away by wind scattering seeds;
- Presence of hairs /wing-like structures/floss/extension which increase surface area for buoyancy; making it easy for fruits/ seeds to be blown away;
- Fruits /seeds are light due to small size; therefore, easily carried away by wind;

58. a) A- Ovary
B- Oviduct/ fallopian tube
C- Uterus/ uterine wall
D- Cervix
- b) Produce ova
Produce female hormones/ Estrogen and progesterone
- c) - Highly vascularized to supply nutrients to foetus/ drain away excretory wastes
- Inner wall lined with Endometrium for implantation of fertilized egg/ zygote
- Muscular for peristalsis to expel menses during menstruation/ parturition
- Great capacity to expand during gestation to accommodate developing foetus
- d) -copulation/ Achieve orgasm in Human male followed by ejaculation
- birth canal
59. a) chorion; Rej Amnion/Amniotic membrane.
- b) i) A: (umbilical Artery; Rej Arteriole
B: (umbilical vein; Rej venule
- ii) More food nutrients; more oxygen in umbilical vein/less food nutrients; more excretory products in umbilical Artery;
Rej.(ii)if (i) is wrong
Rej oxygenated/deoxygenated
- c) highly vascularized;
-large surface area; acc. Numerous villi for large surface area
-presence of secretory cells/are glandular; any 2 Rej. Source of hormones.
- d) cushion /absorbs shock/buoyancy;

]

60. (a)

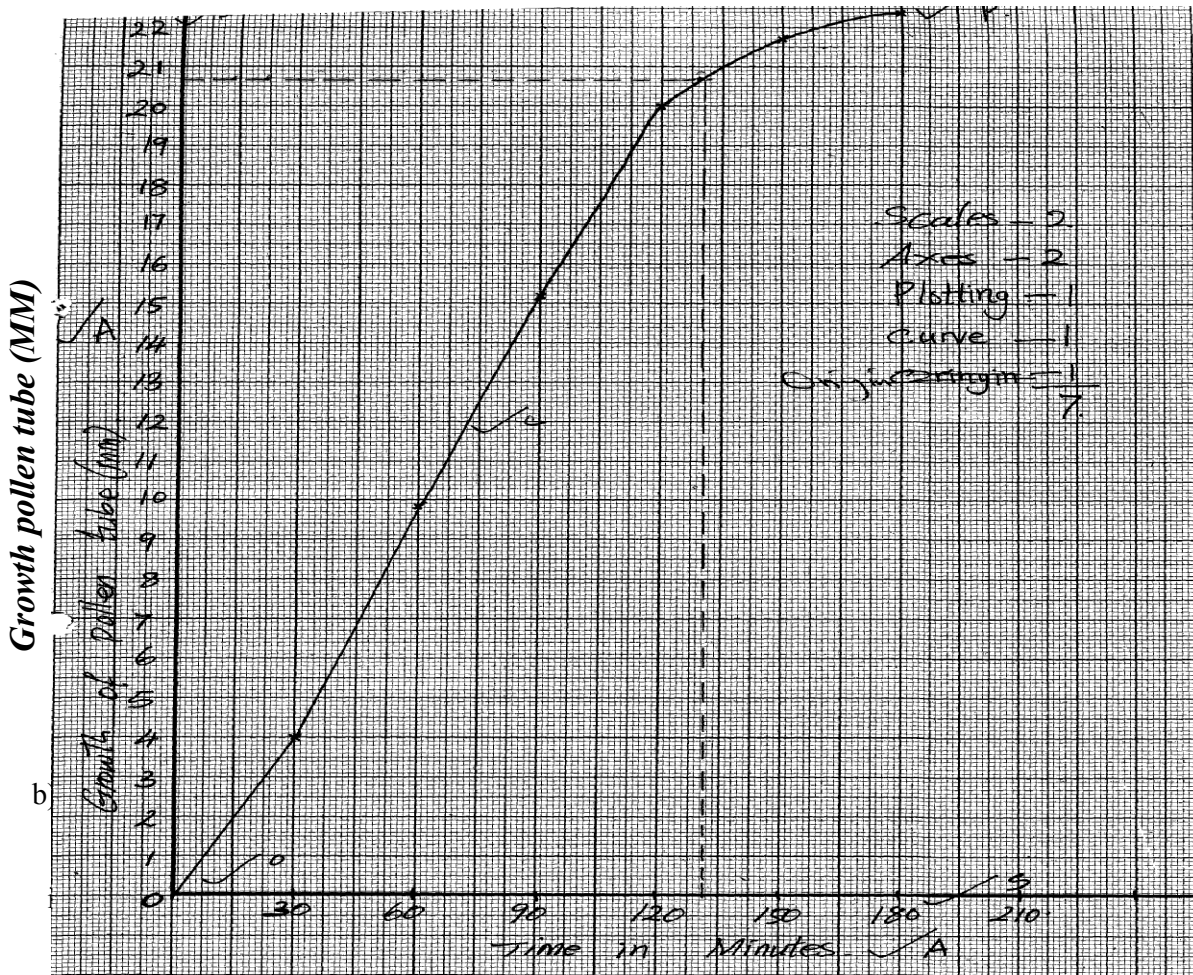

reason: pollen tube young/has enough nutrients in culture;
 to 180 minutes- grows slowly/rate of growth decline /decrease/growth rate pattern decrease;

reason: pollen tube mature/old/has exhausted nutrients;

v) directs role gametes/nuclei/nucleus to ovules; Rej. Ovary/pollen grains for male gametes.

c) integument develop/changes to-seed coat/testa;

zygote-embryo;

triploid nucleus-endosperm;

ovary wall- pericarp;

ovary- fruits;

ovules-seeds;

corolla/petals/style/stamens/filament-dry out /fall off /wither(losing a scar);

calyx may persist(dry up &fall off) Rej. die/disappear.

11. Growth and development in (a) plants (b) animals

1. a) Moulting hormone/ ecdysone
b) It allows growth to take place; since growth can not take place in the presences of the
2. a) Long sightedness/ hypermetropia ;
b) Convex/ converging lenses;
3. (a) – Excretion;
- Osmo-regulation;
(b) – Glucose
- Amino acids;
(c) – Nephritis;
- kidney stones /Gall stones;
- Hepatitis A and B; (mark first 2 pts (2mks))
4. (a) Intermittent growth curve;
(b) Moulting;
(c) Ecdysone;
5. Natural immunity is inherited /transmitted from parent to offspring; Acquired immunity is developed after suffering from a disease or through vaccination;
6. A – Cell elongation/expansion ;
B – Cell division/multiplication ;
C – Cell differentiation/maturation ;
7. Continuous variation shows gradation in characteristic with intermediate; discontinuous shows distinct characteristics between organisms with no intermediate groupings;
8. a) to investigate the effect of the force of gravity on the growth of a seedling (shoot and root);
b) Force of gravity cause accumulation of auxins on the lower side of the seedling
- Higher concentration of auxin will promote growth in the shoot but inhibit growth in the Roots;
- There will be more/ faster growth on the upper side of the root than on the lower side hence the downward bending;
-There will be more/ faster growth on the lower side of the shoot than on the upper part hence the upward curvature;
9. i) Between xylem and phloem;
10. Growth – Increase in size of an organism or its parts due to synthesis of protoplasm
Development – Differentiation and formation of various tissues to perform specialized functions;
11. - Reduce competition between the young ones (larvae) ;
- Avoid predation of the young ones as they are different ;

- The pupa stage can withstand harsh environment by being inactive;
12. Disadvantages of exoskeleton;
 - Limits growth
 - heavy to the insect;
 13. Primary growth results from the activity of primary/embryonic tissues/apical meristems and lead to increase in height, while secondary growth result from activities of secondary meristems; /cambium and leads to increase of girth/diameter /circumference;
 14. i) — Oxidizes food to release energy needed for germination;
 ii) — Stores food for the seed;
 - Stores enzymes;
 15.
 - Selective weeding
 - Ripening of fruits
 - Parthenocorpy
 - Reject Prunning of coffee and tea
 16.
 - -Contraction of muscles
 - Formation of bones
 17. allow growth to the place;
 (ii) Grain/cotyledon remains underground below the soil level: (1 mark)
 18. (a)(i) Hypogeal;
 (b) Photosynthesis; OWTTE
 -Gaseous exchange; accept. Transpiration.
 19. (a) Effect of unilateral/unidirectional light on shoots:
 (b) Seedling/shoots growth towards light' growth curvature towards light;
 20. (a) Intermittent growth;
 (b) Moulting /ecdysis;
 (c) Ecdysone rej. Moulting hormones;
 21. (a) Divide giving rise to more vascular tissues – phloem and xylem; hence leading to secondary growth/thickening of the stem;
 (b) They lack vascular cambium;
 22.
 - It has chondrionic villis to increase surface area for excahgne of materials
 - Has thin epithelium for rapid exchange of exchanged substances
 - Has counter current flow of foetal and maternal blood to enhance speed diffusion gradient.
 - Highly vascularised (dense network of capillaries) for faster transport of exchanged material
 23. (a) For oxidation of stored food;
 (b) Breakdown and oxidation of food
 24. (a) (i) osmotaxi/cremotaxis
 (ii) phototaxis
 (i)Sensory neuron
 (ii) Direction of nerve impulse
 (iii) Schwarn cell
 (iv) insulate the axon/Speed up transmission of impulses
 (c)

Reflex action	Conditioned reflex action
Single stimulus to bring about response. Simplest form of behaviouir and is independent of experience	Repeatal stimulus to bring about response Involves modifications of behaviour and dependent experience .

25.	Sensory and motor component are the same at all times	Primary sensory component is repeated by a sensory component but the motor. Component remains unchanged.
-----	---	--

- (a) To absorb carbon (IV) oxide;
 (b) to provide moisture to germinating seeds;
 (c) (i) (Left – right direction \longrightarrow);
 (ii) Oxygen in the tube is taken up by the seeds for germination; the Carbon (IV Oxide) Produced during respiration and the one in the tube reacts with potassium hydroxide pellets; lowering the pressure inside the set-up; the higher pressure from outside the tube forces the dye in the direction shown;
26. (i) Lag phases; Dry mass increases slowly; because in plant has not developed leaves; for photosynthesis hence is depending on stored food;
 (ii) Exponential phase; Rapid growth /increase in dry mass, leaves developed; photosynthesis taking place leading to accumulation of food and rapid cell division / plant adapted to the environment
 (iii) Death phase/ senescence; Negative growth/decrease in dry mass as some tissues die after reaching maximum maturity; Fall in photosynthesis activity; toxic wastes poison tissues;
- (c) (i) When dry mass was first recorded/at germination
 (ii) Dry mass would decrease first because food is oxidized to produce energy; water and carbon dioxide/utilized in respiration;
- (d) (i) Harvest every week about five seedlings; dry in oven to a constant dry mass; Calculate the average mass for one seedling and record the results.
 (ii) Advantage; Dry mass is not affected by environmental conditions while fresh weight is dependent on the amount of water in the plant which fluctuates with environmental factors affecting transpiration rate.
27. a) klinostat/clinostat;
 b) i) the radicle remains /grow horizontally;
 ii) rotation of klinostat causes uniform distribution of auxins/ indoleacetic acid; hence uniform growth/elongations (no curvature formed);
 c) the experiment repeated but with stationary klinostat;
 d) -(tropism) enable plants to get water-hydrotropism;
 -chemotropism aids plants in fertilization and nutrients absorption;
 -thigmotropism enable weak plants to obtain support

- phototropism enable plants to obtain light for photosynthesis;
- geotropism enables the roots grow down the soil towards the centre of the earth thus providing support to the plant

28. a)graph

- axes have to be labelled- ½ mk@-1mk No axes marking stops there.
- scale-should be appropriate and workable- ½ mk @-1mk
- plotting correctly-1mk@*RCH* *wrong scale stop marking.
- curve-smooth and not extrapolated beyond 3 small squares- ½ mk@-1mk
- identity- ½ mk each-*RCH*

Note/ -axes reversed-award only for identity
 -no origin-award only for one scale/vertical one.

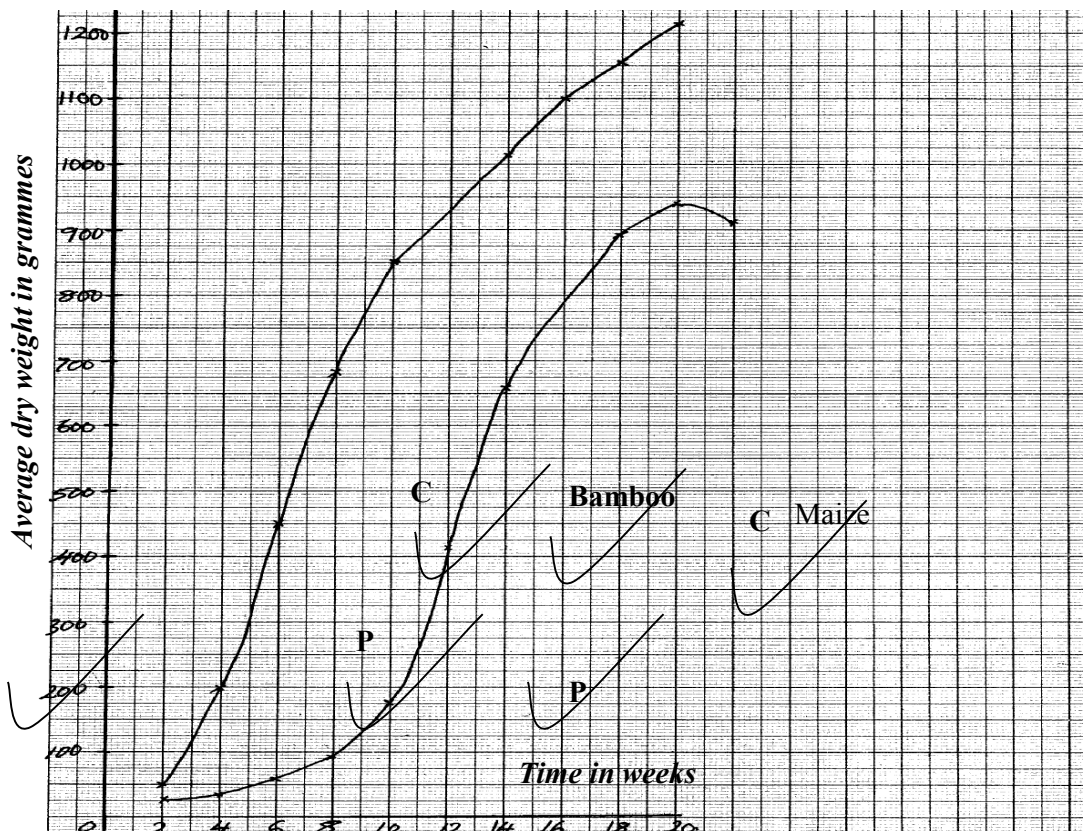

- b) i)bamboo;
- ii)(bamboo)have higher average weigh
- c) i)average height of maize plant between weeks 14 and 18 constant (at 2.1m); maximum height attained; average weight increased; because there was slight increased in the girth;
- ii) dry weight represents the actual dry matter/fresh weight includes weight of water;
- iii)-average height was determined by measuring the length; of the plants at various intervals;
- average dry weight was determined by heating the plants to exclude all the water; and then

- taking their dry weights;
- d) both height and weight are used to show rates of growth;
- e) lacks cambium(tissue)hence no secondary thickening;
29. a) Fusion of an egg cell nucleus with sperm cell nucleus; to form a zygote
- b) i) Meiosis
ii) In the testis/ testes/ ovary/ ovary
- c) i) There is increased blood supply causing thickening of the uterine walls;
ii) Capillaries break up/ endometrium is lost with some blood/ menstruation occurs
- d)
- Large number/ numerous blood vessels to increase surface area for exchange of materials
 - Thin membrane for faster diffusion across it
 - Has villi to increase surface area for diffusion
 - Special cells to produce hormones
 - Membrane selectively allows materials across it
30. a) $\frac{\text{Number of seeds that germinate}}{\text{Number of seeds planted}} \times 100 = \% \text{ seed germination}$
- b) Seeds dry mass would have resulted in death of embryo thus no germination
- c)i) Mean seedling fresh mass include the mass of water that has not resulted from growth
ii) At regular intervals of time; uproot seedlings (say five each) dry to constant weight, and record
- d) Directly proportional / Increase in seed mass results in increase in % seed germination, survival and seedling fresh mass
- e) Embryo well developed/ Embryo very mature;
- Large food reserves for growth and development
30. a) Directly proportional/ increase in enzyme concentration results in increase in reaction rate
- b) i) Increase in substrate concentration results in increase in reaction rate
Increase in concentration results in more active sites occupied by substrate molecules, resulting in higher turn over
ii)A rate of reaction constant/ does not change
Active sites fully occupied
iii) Sharp decrease in reaction rate
Enzymes denatured
- c) PH/ Enzyme inhibitors/ Enzyme co- factors
31. a)

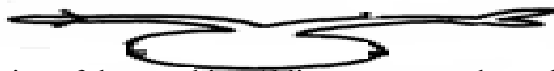

- b) the rotation of the machines/ klinostat ensured equal distribution of Auxins in the seedling (upper & inner) side;
- c) Klinostat;
- d) radicle grow dominants; plumule grow upwards;
- e)

STIMULI	RESPONSE (name)
light	Phototropism;

gravity	Geotropism;
---------	-------------

32. (a) (i) Carbam inohaemoglohin:
 (weak) Carbonic acid: (2marks)
 (ii) Oxyhaemoglobin; (1 mark)
 (b) Secretes pleural fluid:
 - Makes lungs air tight:(OWTTE) (2marks)
 (c) Carboxyhaemoglobin doesn't dissociate readily (OWTTE):
 Hence its formation reduces the capacity of haemoglobin to carry oxygen to time lungs
 hence resulting in death: (2marks)
 (d) Cuticle: lenticels: (Both to be correct to score 1 mark) (1 mark)
33. (a) Region of rapid growth / cell elongation in a radicle: root

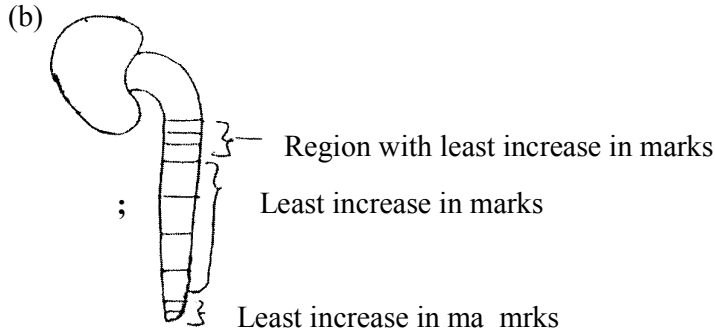

- (c) Dense cytoplasm
 Lack cell vacuoles
 Thin cell walls
- (d) -Presence of germination inhibitors / abscisic acid:
 - Low concentration of hormones / Enzymes/ gibberlic acid:
 - Impermeable seed coats to water and oxygen:
 - Embryo not fully developed:

12. Genetics

- BB;
 - AA;
- Black mice are better adapted camouflage with the environment hence less are eaten by the owls compared to the white mice which are easily seen;
 - Theory of natural selection;
- Heterostly – stigma located above anthers;
 - Self sterility or incompatibility – pollen grain from the same plant do not germinate
 - Protandry – Male parts mature before female parts;
 - Protogyny – Female parts mature before male parts;
- Complete dominance is when an allele completely suppresses another intermediate fruits;
 Incomplete dominance is when heterozygous organisms show an intermediate trait;
 - Genetic recombination's of alleles leading to variations; Independent assortment of chromosomes;

- Random fusion of gametes; mutations;
Environment (may either enhance or suppress expression of a gene);
5. (a) C-A – G – U – C _ A ;
(b) – Stones genetic information (in a coded form);
 - enables transfer of genetic information unchanged to daughter cells through replication);
 - Translates genetic information into characteristic of an organism through protein synthesis);
 6. Ability to pollinate; response to stimuli (tactic) nastic or tropics); Ability to exploit localized nutrients an ability to photosynthesize; Ability to disperse seeds/fruits, propagation;
 7. (a) Glucose;
(b) The person was a sufferer of diabetes mellitus;
(c) Pancrease;
 8. Continuous variation shows gradation in characteristic with intermediate; discontinuous shows distinct characteristics between organisms with no intermediate groupings;
 9. -mutation;
-intermixing of genes already in the population through sexual reproduction recombination;
-crossing over during prophase of meiosis I
-interdependent assortment of chromosomes, during metaphase of meiosis I
 10. i) Substitution;
ii) Deletion;
iii) Inversion;
 11. i) C G G A T C T A G T G;
ii) C G G A U C U A G U G;
 12. a) Continuous ;
b) Nutrition/ environment; genes;
 13. a) Father X^HY ;
Mother X^HX^h ;
b) i) Genes found in the same chromosome and usually transmitted together;
ii) Across to determine an unknown genotype involving use of a recessive parent;
 14. a) Colour blindness; haemophilia;
Sickle cell anaemia;
b) Part of X chromosome has homologous portion on the Y chromosome therefore if the X has the recessive trait, it will show on the male phenotype ;
c) The son inherits the X chromosome from the mother while the daughter inherits the X chromosome from the father;
 15. (a) Inversion ;
 - ustard gas;
 - ionizing radiation;
 - gamma rays;
 - X- rays ;

16. (a) Ribonucleic acid /RNA
 - Because it has uracil / presence of uracil;

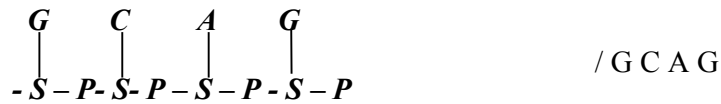

17. (a) Due to co-dominance /partial dominance/incomplete dominance/(Acc. equal dominance)
 (b) Red: 2Pink : white – 1: 2:1 (Acc. 1RR: 2RW: 1WW) mark as a whole;
 (c) Why women should drink extra milk;
 (i) Bone formation for infants ;
 (ii) pressure on bladder by the enlarging uterus;
18. a) Genes which are located on the sex- chromosomes and therefore are transmitted along with them
 Example Haemophilia; colour blindness;
 b) Where more than two genes control a particular characteristic/ trait;
 Example ABO blood group system;
19. a) Parental Genotype Rr, Rr ;
 b) Red: white;
 119/41; 41/41;
 2.90: 1
 3: 1;
20. (i) Y – Chromosome-hairy pinna, pre-mature boldness; ; (any one)
 (ii) X – Chromosome- haemophilia (bleeders disease); colour blindness; (any one)
21. The Gene that determine the growth of long hair on pinna is sex linked and an Y-chromosomes; V hence can only be inherited by males as a single gene and it expresses itself out phenotypically
22. Due to crossing over: that results in exchange of genetic materials between homologous chromosomes;
23. (a) Co dominance/ incomplete dominance:
 (b) 1 Red flowered; 2 pink flowered; 1 white flowered: for ratio for phenotype)
24. (a) Albinism;
 (b) Makes skin supple;
 - Kills bacteria/ a mild antiseptic;
25. - Change in base sequence of the DNA; ✓ 1.
26. (i) Sudden and spontaneous change in structure of chromosome and DNA which is inherited
 (ii) Chemical ionizing radiations, Uv light, extreme temperature or some virus

27. (a) GCCTATG – DNA
GCCUAUG- MRNA
(b) Ribosome;

28. a) Parental phenotype Pink flight feathers $X^{R}X^{r}$ X White flight feathers $X^{r}Y$
Parental genotype
Parental gametes $\begin{matrix} R \\ X \end{matrix}$ $\begin{matrix} r \\ X \end{matrix}$ $\begin{matrix} r \\ X \end{matrix}$ $\begin{matrix} r \\ Y \end{matrix}$

Fusion
F1 genotypes Rr/XX Rr/XY rr/XX rr/XY ;

b) incomplete;
c) i) Ribonucleic acid;
ii) has uracil base;
ii) – 3;
- There are three codons;

29. A – $X^{h}Y$;
B – $X^{H}Y$;
F – $X^{H}X^{h}$;

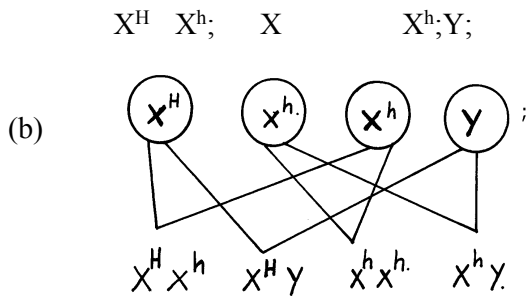

(c) Albinism; sickle cell anaemia; colour blindness; chondrodystrophic dwarfism;

30. (i) Father $X^{H}Y$ Mother $X^{H}X^{h}$
Since father cannot have the recessive gene and fail to be affected. The mother must be a carrier on her second X chromosome for a male son to be haemophiliac.
(ii) Parental phenotypes mother carrier, father normal

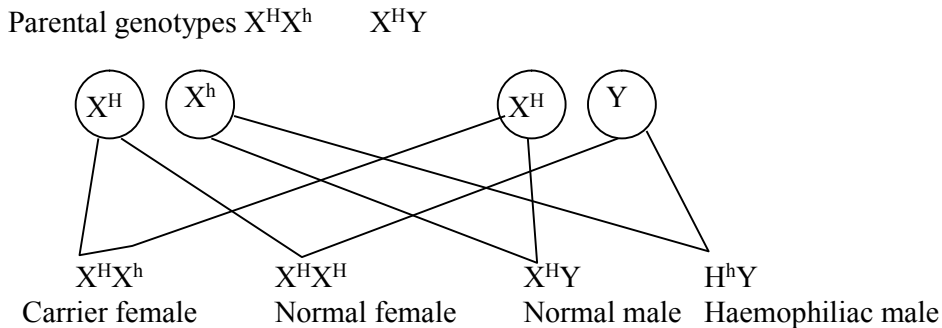

31. a) the two genes that control flower colour ,that is the gene for red flowers and the one for white are codominate;

b) F₁ phenotype pink flowers pink flowers

F₁ genotype RW X RW ;

Gameter $\textcircled{R} \textcircled{W}$ $\textcircled{R} \textcircled{W}$;

Fussion

F₂ genotypes RR RW RW WW;

F₂ phenotypes red pink white flowered ;
 Flowered pink white flowered ;
 Flowered

c) genotypic ratio= 1RR:2RW:1WW/RR:RW:WW=1:2:1 ;

Phenotypic ratio=1 red flowered:2 pink flowered:1 white flowered ;

Notes: i) there must be cross on genotype

ii) gameter should be circled

d) recessive gene expressed it self only underlined homozygous condition while dominant gene expresses it self in both homozygous and heterozygous conditions;

32. (a) (i) Male and female flowers are separate hence cross pollination is made possible.

(ii) 1 Yellow : 3 Purple
 Rej.: 15 yellow : 45 Purple

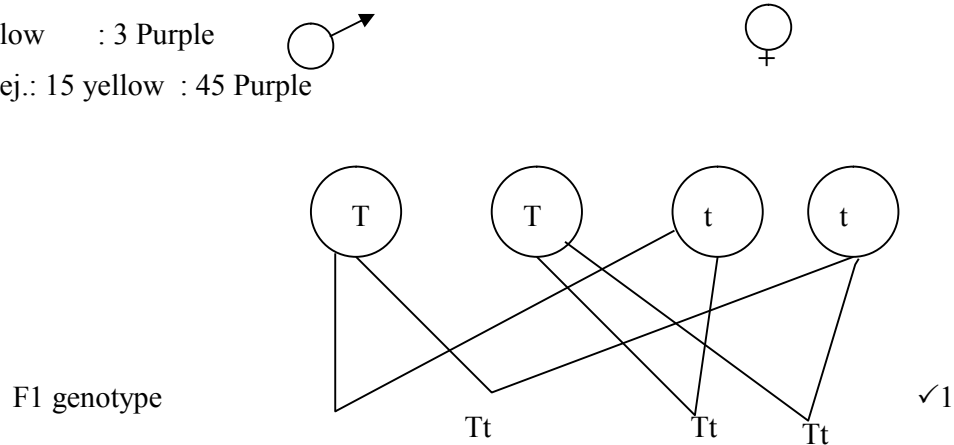

(b) Let letter T represents purple maize grain

Let letter t represent yellow maize grain

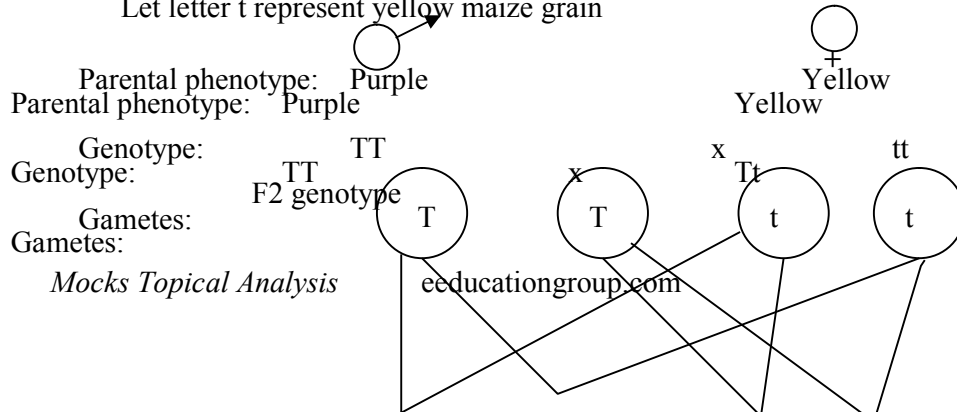

- (c) Gene for purple grain;
 (d) (i) Finger prints are used to identify criminals;
 (ii) Blood groups are used to settle parental disputes;

33. a) Aa; Aa; because of one child - 4
 b) AA; Aa; because of cross between parent 1 and 2
 c) Lethal genes easily inherited;
 d) Sickle celled anaemia; colour blindness; haemophilia

34. (a) Y – Blood group A⁺;
 Z – Blood group B⁻

(b)

Parental phenotypes	♂ Rhesus (+ve)	Rhesus (-ve)
Parental phenotypes	Rh Rh	Rhd Rhd;

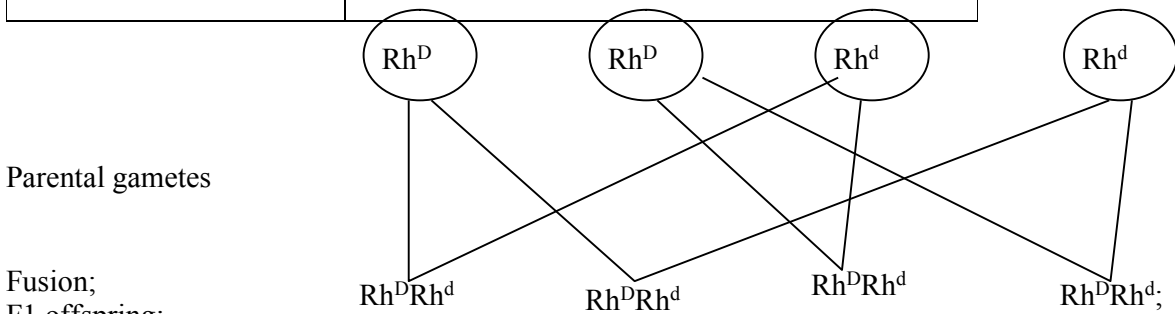

- Fusion;
 F1 offspring;
 c) All Rhesus positive/ all Rh^DRh^d;
 (d) None

35. – By keeping their mouth open/panting; to lose heat over surface area of the tongue by evaporation;
 -Basking; to gain heat by conduction;
 - Shivering; to generate heat through increased metabolism;
 - Physical activity (e.g. running); to generate heat through metabolism;
 - Hibernation; to increase metabolism;
 - Putting on warm clothes when it is cold; to retain the heat energy;
 - Reduction of physical activity; to reduce the metabolic rate;
 - Migratory behaviour to cooler environment; to reduce the body temperature;
 - Moving into water when it is hot; to cool the body;
 - Staying around fire place; to gain heat by convection;
 - Taking hot drinks; to warm the body;

36. a) Parental genotypes
 i) Woman/ O^X - AO

ii) Man/ O - BO

b

	A	O
B	AB	BO
O	AO	OO

c) Cases of disputed paternity settlement

- Determining compatible blood groups in blood transfusion

d) i) Corresponding complementary DNA strand GAA;

ii) Corresponding RNA CUU

iii) Nitrates/ sulphites/ hydroquinone/ gamma/ beta/ alpha/ x-rays/ UV light/ hydrogen peroxide

37. let R rep. gene for Red flowers

W.rep gene for white flowers

a) parental phenotype Pink flowered
genotype RW X RW ;

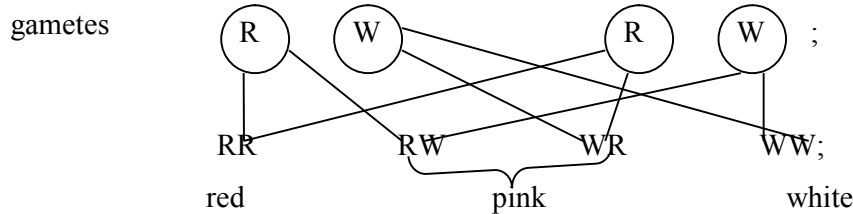

b) phenotypic ratio 1Red:2Pink:1White;

genotypic ratio: 1RR:2RW:1WW;

c) $\frac{2}{4} \times 480 = 240$

4

38.

Parental genotype;

Gametes ;

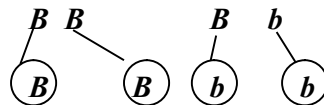

♂	B	Bb
♀	b	Bb
	b	Bb

F1 generation Award for punnet Square and genotypes

(b) (i) 1BB : 2Bb: 1bb

(1 mark for ratio, 1 mark Par genotype)

(ii) 3 B lack: 1 brown

(iii) 24;

39. (a) Homologous structures:

Structures of common embryonic origin modified to perform different functions;

Example: Eye structure in man and octopus/ wings in birds and insects (1 mark)

Analogous structures Example

- (b) They undergo mutations: resulting in new forms that resist selection resistant to drugs;
- (c) (i) Failure of chromosomes to separate during anaphase I resulting in gametes with an extra chromosome and others with less chromosomes: (1 mark)
- (ii) Downs syndrome / Klinefelters syndrome/ Turners syndrome: any 1 (1mk)
40. a) Homologous structures have a common embryonic origin but are modified to perform different functions; while analogous structures have different embryonic origin but are modified to perform similar functions;
- b) Nictitating membrane; post anal tail; body hair;
41. a) Pentadactyl limb structure of mammals; beaks of birds; feet of birds;
- b) - Missing links between fossils because some parts or whole organisms were not fossilized
- Some parts were distorted during fossilization hence may give wrong impression of structures;
- Some structures have been destroyed by geological activities;
42. Camouflage is the conceal/ element of identity of an organism by resembling the color of the environment while mimicry is the imitation of non- living organisms to conceal identity
43. Light energy splits water molecules; into hydrogen ions and oxygen atoms;
44. (a) Caecum/ Rumen/ pauch;
- (b) Closes to prevent food from moving up the oesophagus;
45. (a) – the soft bodied organisms fail to fossilize;
- Human activities interfere with fossilization;
Earth movements e.g. volcanic eruptions interfere with fossilization; (mark any first 2 pts)
- (b) – They resembled from neck downwards;
-They walked upright;
- The shape of the skull suggested they were able to speak;
46. a) i) vestigial structures are those structures that have ceased to be functional over a long period of time and hence reduced in size
ii) - appendix;
- caecum
- coccyx or tail/tail bone;
- Nictitating membrane/semi - lunar fold at the corner of the eye;
- ear muscles
- Body hair;
- b) Disease causing organism mutates; and became resistant;
47. Struggle for existence – environmental pressure on the population in order to survive;
Survival for the fittest-advantageous variations an individual possesses to make it survive;
48. Secretion of antidiuretic hormone; reabsorption of salts at the loop of Henle;
49. -Divergent evolution refers to a situation where by organisms that are believed to have had a common ancestral origin have homologous structures which have been modified to suit different environments;
50. a) Allows survival of organisms with better qualities / traits / characteristics; eliminates organisms with unfavorable characteristics/ traits;
b) Divergent;
51. Evidence does not support Larmarks theory
Acquired characteristics are not inherited/;
Inherited characteristics are found in reproductive cells ;
52. (a) Vestigial structures
(i) Are those structures that have ceased to be functional over a long period of time hence reduced in size;
(ii) Appendix/coccyx/tail/ nictitating membrane semilun fold at the corner of the

- eye/caecum/ear muscles, body hairs;
- (b) Disease causing micro-organisms mutate and become resistant;
- 53. a) The gradual emergence of complex life forms from pre-existing simple forms over along period of time ;
- b) Nature selects those organisms with structures that are well adapted to survival in the environment. These structures are passed to their offspring; organisms with structures that are poorly adapted perish ;
- 54. The insecticide kills most of the insects when introduced; those that survive; give rise to a new generation of flies that are resistant to insecticide.
- 55. - Most organisms especially soft-bodied ones do not form fossils;
- Most fossils have not yet been discovered;
- Exposed fossils are usually destroyed by physical and chemical weathering;
- Earth movements e.g. volcanicity, earthquakes, tsunami do destroy fossils;
- Most animals are preyed upon;
- 56. -Fossil records/paleontology ;
- Comparative anatomy/taxonomy;
- Comparative embryology;
- Geographical distribution;
- Cell biology;
- Comparative cellology/immunology; (award 1st three 3mks)

13. Evolution

1. a) Homologous structures have a common embryonic origin but are modified to perform different functions; while analogous structures have different embryonic origin but are modified to perform similar functions;
- b) Nictitating membrane; post anal tail; body hair;
2. a) Pentadactyl limb structure of mammals; beaks of birds; feet of birds;
- b) - Missing links between fossils because some parts or whole organisms were not fossilized
- Some parts were distorted during fossilization hence may give wrong impression of structures;
- Some structures have been destructed by geological activities;
3. Camouflage is the conceal/ element of identity of an organism by resembling the color of the environment while mimicry is the imitation of non- living organisms to conceal identity
4. Light energy splits water molecules; into hydrogen ions and oxygen atoms;
5. (a) Caecum/ Rumen/ pauch;
- (b) Closes to prevent food from moving up the oesophagus;
6. (a) – the soft bodied organisms fail to fossilize;
- Human activities interfere with fossilization;
- Earth movements e.g. volcanic eruptions interfere with fossilization; (mark any first2 pts
- (b) – They resembled from neck downwards;
- They walked upright;
- The shape of the skull suggested they were able to speak;
7. a i)vestigial structures are those structures that have ceased to be functional over along period of time and hence reduced in sizes
- ii)-appendix;
- caecum
- coccyx or tail/tail bone;
- Nictitating membrane/semi - lunar fold at the corner of the eye;
- ear muscles

- Body hair;
- b) Disease causing organism mutates; and became resistant;
- 8. Struggle for existence –environmental pressure on the population in order to survive;
Survival for the fittest-advantageous variations an individual possesses to make it survive;
- 9. Secretion of antidiuretic hormone; reabsorption of salts at the loop of Henle;
- 10. -Divergent evolution refers to a situation where by organisms that are believed to have had a common ancestral origin have homologous structures which have been modified to suit different environments;
- 11. a) Allows survival of organisms with better qualities / traits / characteristics; eliminates organisms with unfavorable characteristics/ traits;
- b) Divergent;
- 12. Evidence does not support Larmarks theory
Acquired characteristics are not inherited/;
Inherited characteristics are found in reproductive cells ;
- 13. (a) Vestigial structures
(i) Are those structures that have ceased to be functional over a long period of time hence reduced in size;
- (ii) Appendix/coccyx/tail/ nictitating membrane semilun fold at the corner of the eye/caecum/ear muscles, body hairs;
- (b) Disease causing micro-organisms mutate and become resistant;
- 14. a) The gradual emergence of complex life forms from pre-existing simple forms over along period of time ;
- b) Nature selects those organisms with structures that are well adapted to survival in the environment. These structures are passed to their offspring; organisms with structures that are poorly adapted perish ;
- 15. The insecticide kills most of the insects when introduced; those that survive; give rise to a new generation of flies that are resistant to insecticide.
- 16. - Most organisms especially soft-bodied ones do not form fossils;
- Most fossils have not yet been discovered;
- Exposed fossils are usually destroyed by physical and chemical weathering;
- Earth movements e.g. volcanicity, earthquakes, tsunami do destroy fossils;
- Most animals are prayed upon;
- 17. -Fossil records/paleontology ;
- Comparative anatomy/taxonomy;
- Comparative embryology;
- Geographical distribution;
- Cell biology;
- Comparative cellulogy/immunology; (award 1st three 3mks)
- 18. Nature selects organisms that are well adapted and allows them to survive: but rejects those that are poorly adapted they perish/die/become eliminated;
- 19. (a) The genotype of an organism is not changed by characteristics acquired during the life/ phenotypically acquired characteristics do not affect the genotype of an individual
- (b) - Missing links (due to decomp0osing of savaged form)
- Distortion of parts (some parts were flattened);
- Geographical activities (e.g. earthquake, faulting, erosion) (any 2)
- 20. (a) White flowers.
- (b) The white flowers were fewer that is the ratio of ¼ of the total flowers.

Parental phenotype white flowers white flowers
Parental genotypes r r x v r

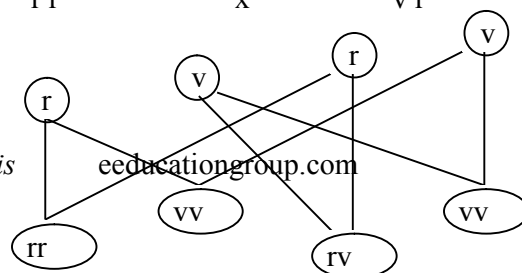

- (c) A cross between unknown genotype with a homozygous recessive/double recessive genotype
(d) - Low mental capability
- Short/stubby fingers
- Slit eyes
21. (a) Emergence of new life forms//species//organisms; from pre-existing forms gradually over a long period of time;
(b) Fossil records//Palaeontology:
These are remains of organisms preserved in some naturally occurring materials e.g. sedimentary rocks for many years; They give direct evidence of the type of organisms that existed at a certain geological time//show a gradual increase in complexity/morphological changes of organisms over a long period of time e.g. skull of man
Geographical distribution:
present continents are thought to have been a large land mass joined together; continental drift led to isolation that lead to different patterns of evolution; e.g. camels of Africa resemble the llamas of S. America// tiger of Asia resemble jaguars of S. America // unique Marsupials of Australia; (accept any valid example)
Comparative Embryology:
Vertebrate embryos show morphological similarities in their early development; suggesting these organisms have a common origin; Accept – embryos of mammals /reptiles/ amphibians compared to show the similarities;
Cell Biology// Cytology:
Occurrence of cell organelles e.g. Mitochondria
Cytoplasm nucleus// Accept any correct organelle; point towards a common ancestor;
Comparative serology:
Analysis of blood proteins and antigens / Rh factor/ blood group /haemoglobin reveal phylogenetic blood group/haemoglobin reveal phylogenetic relationships; Those species that are more close phylogenetically related contain more similar blood protein;// Antigen-antibody reactions/serological tests/experiments with serum reveal some phylogenetic relationship depending on the level of precipitation.
Comparative anatomy/taxonomy:
- Members of a phylum show similarities indicating common ancestry; These organisms have similar functions e.g. presence of digestive, urinary, nervous systems e.t.c;
- Homologous structures like pentadactyl limbs in different animals like monkey and rats have similar bone arrangement hence same origin but modified to perform different functions// adaptive radiation//divergent evolution; vestigial organs//coccyx Appendix;
- Analogous structures like wings of birds and wings of insects with different embryonic origin but perform same function//convergent evolution; (maximum 18mks)
- N/B- Mention of each evidence 1mk each
- It is muscular//Has cardiac muscles which are myogenic;//capable of contracting and relaxing without nervous stimulation to ensure the heart beat without stopping;
 - Supplied by vagus and sympathetic nerves; which control the rate of heart beat depending on body's physiological requirement;

- Has tricuspid and bicuspid valves//arteria ventricular valves; to prevent back flow of blood into wrong directions;
- Has semi lunar valves at the base of pulmonary artery and aorta; to prevent back flow of blood into right and left ventricles respectively;
- Presence of valve tendons attached to the walls //arteria ventricular walls; prevent arteria ventricular valves // tricuspid and bicuspid valves from turning inside out;
- Supplied by coronary artery; to supply food and oxygen t the cardiac muscles for their pumping action;
- Coronary vein; draws away metabolic wastes;
- Heart is enclosed by pericardial membrane; which secrete fluids which lubricates//reduces friction on the walls as it pumps;
- Pericardial membrane is lined with a layer of fat to act as shock absorber; hold the heart in position; checks over dilation of the heart;
- The heart is divided into two by (artria ventricular) septum; which prevents mixing of oxygenated and deoxygenated blood;
- The sino-artria node// pace maker; initiates a wave of excitation leading to contraction and relaxation of cardiac muscles;
- The artria –ventricular node; in the heart spread out waves of excitation through out the heart

The structure tied to function wrong function cancel the mark of the structure. Correct structure minus function do not qualify for a mark

22. (a) Nature or the environment selects those individuals that are sufficiently adapted; and rejects those that are not adapted;
- (b) Adaptation by natural selection.
- Individuals of the same species show variations.
 - The variations are caused by genes that can be passed on from parents to the off springs (inherited);
 - Some of these variation become more suitable or favorable or advantageous in the prevailing environmental conditions;
 - Because organisms usually produce more off springs than the environment can support; competition for resources sets in;
 - This leads to struggle for existence;
 - Individuals with more favorable characteristics/ adaptations/ gene mutation have better chance of survival in the struggle;
 - Hence they reach reproductive age, reproduce and pass on favorable characteristics to the off spring;
 - Those with less favorable characteristics or adaptations fail to reach sexual maturity; they die young;
 - Examples of natural selection include- malarial parasite/plasmodium which has developed strains that are resistant to anti-malarial drugs;
 - Sickle cell trait; the homozygous die young and the heterozygous are resistant to malaria.
- (c) – Convergent evolution.
- This is a phenomenon where structures from different embryonic origins are modified to perform the same function. E.g. wings of birds and those of insects, eyes of human beings and those of octopuses;
 - Divergent evolution.
 - This is a phenomenon where one basic structural form is modified to give rise to various different forms which perform different functions. E.g. pentadactyl limbs of vertebrates, shapes of beaks in birds;
- (d) Evidences to show that evolution has taken place. (Any 4)

- i) Fossil records. ✓
 - ii) Comparative anatomy. . ✓
 - iii) Comparative embryology. . ✓
 - iv) Geographical distribution (continental drift). ✓
 - v) Vestigial organs. ✓
 - vi) Cell biology. ✓
- (i) Fossils records;
Fossils are remains of dead organisms preserved naturally. They indicate that organisms have evolved from simple life forms to most complex forms. Fossils of human beings indicate that the modern human being has a highly developed brain and uses speech for communication unlike the early human being. Of horses show that the modern horse is 1.5 m high, lives in dry grassland, teeth are adapted for chewing and it stands on one digit whose distal end is converted into hoof.
- (ii) Comparative Anatomy;
This involves comparing the form and structure of different organisms. Some groups organisms show basic structural similarities suggesting common or related ancestry showing divergent evolution.
Other groups of organisms show morphological similarities but are found to have different ancestry showing convergent evolution;
- (iii) Vestigial Organs;
Some structures have ceased to be functional and have reduced in size; such structures are called vestigial structures. Examples include the appendix and the tail in human beings; reduced wings in flightless birds, nictitating membranes in mammalian eyes and lack of visible limbs in pythons.
- (iv) Geographical distribution;
- Its believed that long ago the land was one mass which later drifted apart to form the current continents. This is called the continental drift.
- Regions with similar climatic conditions and lie in the same latitude have flora and fauna that are not identical. This indicates that they have evolved differently; e.g. Amazon forest of South America has long tailed monkeys, panthers and jaguars while similar African forests have short tailed monkeys, leopards and cheetahs.
- (v) Comparative embryology;
Studies show that embryos of fish, birds, amphibians, reptiles and mammals are morphologically similar during the early stages of development but with time they develop and change to look like their parents;
- (vi) Cell biology;
- Cells of higher organisms show basic similarities in their structure and function; e.g. the presence of cell membranes and organelles such as mitochondria, ribosomes and golgi bodies.
- Higher plant cells have cellulose cell walls, chloroplasts and starch showing evolution from a common ancestry.
- The blood pigment, haemoglobin is common in vertebrates and invertebrates.
23. a) organic evolution is the process by which changes in the genetic composition occur in response to environmental changes *RCH*
b) within the population some individual posses the gene for resistance to the antibiotic or it develops the genes by mutation ; such genes lead to production of enzyme which neutralize the antibiotic; the resistance forms survive the antibiotic hence transmit their advantages

genes to their offspring; thus a new population of resistance strains is established (emergence of new species (speciation))

c) fossil records;

- remains of ancestral forms that were accidentally preserved in some naturally occurring materials
- they give direct evidence of the type of animals and plants that existed at a certain geological age
- the fossil records also show gradual increases in complexity of organism over time e.g. evolution of man
- by comparing fossils of different organisms it is possible to tell the phylogenetic relationship between the organisms

24.

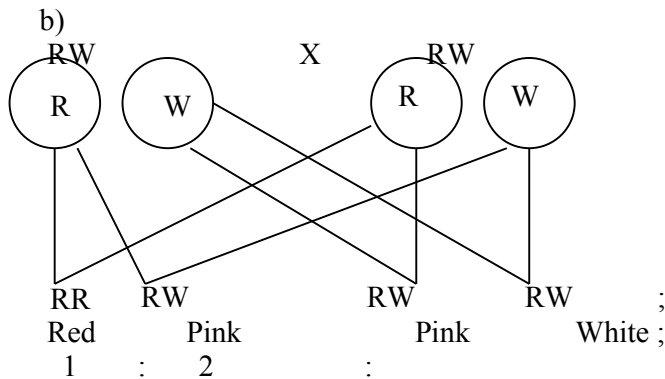
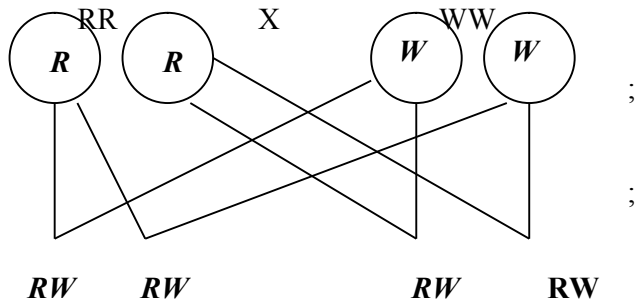

c) Gene for red colour and white colour in flowers are co dominant/ equal dominance/ none is dominant/ recessive

14. Irritability and sensitivity in (a) plants (b) animals

1.
 - To prevent excessive water loss/desiccation;
 - Provide surface area for muscle attachment;
 - Support and protect inner delicate tissues;
2.
 - a) Phototropism;
 - b) Auxins migrate from the side of the shoot that is exposed to light towards the darker side; The higher concentration of auxins on the darker side stimulates rapid growth hence the

shoot bends towards the light source;

3.
 - a) Iris;
 - b) Circular muscles relax; radial muscles contract widening the pupil;
 - c) Adjustment of the eye structure to bring an image from a near or far object into sharp focus on the retina;

4. a)

Taxes	Tropisms
- Locomotory responses	- Growth responses
- Fast response	- Slow response
- No hormones involved	- Influenced by hormones

- (b) – Escape from harmful conditions/stimuli;
 - Move in search of food/nutrients;

5.
 - (a) (i) Motor neurone;
 - (ii) Cell body located in the central nervous system;
 - (b) Arrow head towards terminal dendrites
 - (c) C- Protection/insulate axon;
 - D- Speeds up transmission of an impulse

6.
 - (a) Due to the difference in atmospheric pressure and the pressure inside the ear;
 - (b) Swallowing; yawning;

7.
 - (a) Photosynthesis;
 - (b) Night on the left side makes the auxin to move/migrate/Diffuse to the darker side; there auxin causes faster elongation/growth on the dark side; Hence curvature/bending;

8.
 - Colour blindness;
 - Haemophilia;
 - Sickle cell anemia;
 - Albinism

9.
 - a) short-sightedness/myopia;
 - b) This defect can be corrected by wearing glasses with concave (diverging) lenses; these bend light rays outwards before they reach the eyes enabling them to be focused on the retina;

10. a)

Arteries	Veins
- Thick muscular	- Thin muscular walls
- No valves (except pulmonary artery and aorta at the base	- valves present;
- Narrow (small) lumen	- Wide lumen (large) lumen;

- b) Arteriosclerosis; reject Artheroma

11.
 - a) Retina;
 - b) Cones and rods;

12. a) Long sightedness / hyper metropia..

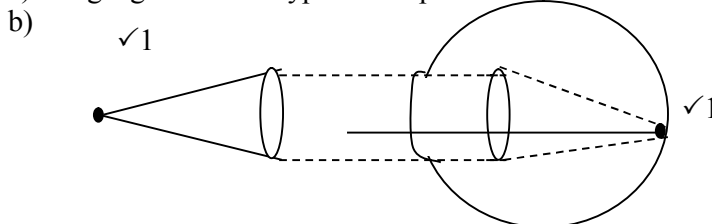

- c) Stereoscopic vision/ binocular vision/ improved visual acuity; gives a wider angle of vision; if one is damaged man is not blinded;
13. Water proof – Prevent water from reaching the inner cells
Has Karatin – For protection against mechanical injury
14. i) Equalizes the pressure between the outer ear and the middle ear;
ii) Transmits and amplifies vibrations from the ear drum to the oval window;
15. a) – Conditioned reflex requires repeated stimulus to bring about response while simple reflex requires single stimulus to bring about response;
- Conditioned reflex requires behaviour modification hence experience while simple reflex involves direct action and is independent of experience;
b) It has a long axon to transmit nerve impulse myelin sheath and rod of ranvier for faster impulse transmission;
16. a) i) Iris;
ii) Optic name;
b) Circular muscles of the iris;
Radial muscles contract;
The size of the pupil enlarge to allow more light to enter;
17. Chemotropism; Reject chemotropism
Negative photo taxis; Reject photo taxis alone
18. i) Thigmotropism / 1-laptotropism
ii) High concentration of auxin on side away from contact surface; promotes faster growth of this side; causing tendril to curl round the object.
19. Thigmotropism / haptotropism;
20. a)Hormone/growth substance /IAA; which inhibits the development/growth of lateral shoots/buds/causes apical dominance; /removal of the terminal buds cause the growth/development and sprouting of lateral buds ; 2mks
b)The pruning of coffee /tea/ledge; etc Rej. Pruning alone/trimming ;
21. cerebrum/cerebral hemisphere/cerebral cortex;
22. a)long sightedness/hyper netropia;
b)the eye ball too short/eye lenses are unable to focus because they are flat//thin/weak; hence unable to focus the image on the retina OR the eye are unable to commodate/change their focal length; 2
c)by wearing convex/biconvex lens/converging lenses; 1mk
23. a)A-relay/intermediate /associates;
B-motor neurone/efferent neurone;
b) Impulse initiates release of acetyl choline /transmitter substance (at the end of the sensory neurone);acetyl choline which diffuses across the gap; generate an impulse in the next neurone; (Rj. Message for impulse)
24. (a) -Hearing;
-Body balance (and posture);
(b) Coiled to accommodate many sensory cells:
- Filled with endolymph to transmit (sound) vibrations.
- Has sensory hairs/cells to generate nerve impulses when stimulated:
25. Used in the transmission of nerve impulse. ✓
- For respiration; ✓
26. - Proper functioning of the nervous system and alimentary canal; ✓
27. (a) Enables the organism to escape from injurious stimuli/seek favourable habitats;
(b) Cerebrum
28. The conified layer of the epidermis consist of dead cells which form a tough outer coat; that protects the skin against mechanical damage/bacterial infection/ water loss;

- Sebaceous glands produce an oily secretion sebum which give hair its water repelling property; that keeps the epidermis supple and prevents it from drying/sebum too prevents bacterial attack due to its antiseptic property;
 Has blood vessels; that dilate and contract;
 In hot conditions, they dilate; increasing blood flow near the skin surface enhancing blood flow near the skin surface; minimizing heat loss;
 Has hairs; stand during cold weather thus trapping a layer of air which prevents heat loss; In hot weather they i.e close to the skin surface; to enhance heat loss to the atmosphere.
 Hair follicle; has many sensory neurons which respond to movements of the hair; increasing sensitivity of the skins. Has subcutaneous layer; contains fat which acts as a heat-insulating layer and a fuel storage;
 Has malpighian layer; consists of actively dividing cells that contain fine granules of melanin; that prevents the skin against ultraviolet light rays from the sun;
29. a) i) Myopia/ short sightedness
 ii) Long eyeball/ too long eye ball
 b) Use of concave/ diverging lens; to diverge the rays from image to focus onto retina
 c) For colour reception/ vision
 For vision in bright light/ day
 d) Retina has many rods; to perceive / enable organism see in dim light/ darkness
30. Water proof – Prevent water from reaching the inner cells
 Has Keratin – For protection against mechanical injury
31. i) Equalizes the pressure between the outer ear and the middle ear;
 ii) Transmits and amplifies vibrations from the ear drum to the oval window;
32. a) – Conditioned reflex requires repeated stimulus to bring about response while simple reflex requires single stimulus to bring about response;
 - Conditioned reflex requires behaviour modification hence experience while simple reflex involves direct action and is independent of experience;
 b) It has a long axon to transmit nerve impulse myelin sheath and node of Ranvier for faster impulse transmission;
33. a) i) Iris; ii) Optic nerve;
 b) Circular muscles of the iris; Radial muscles contract;
 The size of the pupil enlarge to allow more light to enter;
34. Chemotropism; Reject chemotropism
 Negative phototaxis; Reject phototaxis alone
35. i) Thigmotropism / Geotropism
 ii) High concentration of auxin on side away from contact surface; promotes faster growth of this side; causing tendril to curl round the object.
36. Thigmotropism / Geotropism;
37. a) Hormone/growth substance /IAA; which inhibits the development/growth of lateral shoots/buds/causes apical dominance; /removal of the terminal buds cause the growth/development and sprouting of lateral buds ; 2mks
 b) The pruning of coffee /tea/leaves; etc Rej. Pruning alone/trimming ;
38. cerebrum/cerebral hemisphere/cerebral cortex;
39. a) long sightedness/hypermetropia;
 b) the eye ball too short/eye lenses are unable to focus because they are flat//thin/weak; hence unable to focus the image on the retina OR the eye are unable to accommodate/change their focal length; 2
 c) by wearing convex/biconvex lens/converging lenses; 1mk
40. a) A-relay/intermediate /associates;
 B-motor neurone/efferent neurone;

- b) Impulse initiates release of acetyl choline /transmitter substance (at the end of the sensory neurone);acetyl choline which diffuses across the gap; generate an impulse in the next neurone; (Rj. Message for impulse)
41. (a) -Hearing;
-Body balance (and posture);
(b) Coiled to accommodate many sensory cells:
- Filled with endolymph to transmit (sound) vibrations.
- Has sensory hairs/cells to generate nerve impulses when stimulated:
42. Used in the transmission of nerve impulse. ✓
43. - Proper functioning of the nervous system and alimentary canal; ✓
- For respiration; ✓
44. (a) Enables the organism to escape from injurious stimuli/seek favourable habitats;
(b) Cerebrum
45. (a) Positive phototropism; reject phototropism only
(b) Positive geotropism; reject geotropism only
(c) Thigmotropism
46. - cornified layer made of dead cells to protect from mechanical damage, also protect *KKE* from desiccation/dehydration.
- Granular with living cells to replace the worn out layer.
- Malphigian layer – cells divide to form new epidermis.
- Malphigian cells with melanin pigment which protect from c ultra violet rays from the sun.
- Blood vessels to supply oxygen and nutrients. Remove CO₂ and nitrogenous wastes.
- Superficial blood vessels/arterioles dilate. When it is hot. So that more blood flows near the skin surface for more heat loss.
- Superficial blood vessels constrict/vasoconstriction. When it is cold. So that less blood flows near the skin surface to reduce heat loss.
- Erector pili muscle contract when it is cold to raise hair/hair stands upright. To trap more air to reduce heat loss/insulate.
- Erector pili muscles relax when it is hot to make hair lie flat. On the skin to trap less air hence reduce insulation/increase heat loss.
- Sweat glands excrete excess water, mineral salts traces of lactic acid.
- The water in sweat evaporates carrying away latent heat of vaporization to lower the body temperature.
- Subcutaneous layer/dispose tissue insulation the body/ reduce heat loss.
- Sensory nerve ending which are sensitive to touch/pain/heat cold.
47. Conjunctiva – protects eyeball from mechanical injury
Cornea – Allows light to pass through
Iris – Controls amount of light passing through
Retina – Where image is formed
Fovea – Where image is formed
Sclera – Protect the eye ball; give it shape
Choroid – Absorbs stray lights
Provide nourishment to the eye
Aqueous/ vitreous humour – refract light into the eye towards retina maintain shape of eye ball
Ciliary body – Controls curvature of the lens
Rods – Perceive light of low intensity
Cones – Perceive light of high intensity

15. Support and movement in (a) Plants (b) animals

1.
 - a) have closely packed cells which when turgid provide mechanical support;
 - b) Their walls are thickened with cellulose which offer mechanical support;
 - c) Consists of dead cells thickened with lignin;
2.
 - a) Lumbar vertebra;
 - b)
 - Broad neural spine;
 - Large and broad centrum;
 - Broad and long transverse processes;
 - c) Passage of spinal cord;
3.
 - (a) Cervical vertebra;
 - (b) R – (Facel) for articulation with the next vertebra;
S- (Transverse process) for attachment of muscles;
 - (c) Treck region/ cervical region;
4.
 - (i) Humerous; Scapula;
 - (ii) Synovial fluid; Lubrication of bones/prevent friction;
5.
 - Endoskeleton;
 - Hydrostatic skeleton;
 - Exoskeleton;

6.

Muscle cell	Palisade cell
<ul style="list-style-type: none"> - Lacks chloroplast - lacks cell wall - small in size - presence of centrioles - tiny and numerous 	<ul style="list-style-type: none"> - Has chloroplast; - has cell wall; - large in size ; - lack of centrioles; - large central cell vacuole ;

7.
 - a) Ulna;
 - b) i) Humerus;
ii) Hinge
8.
 - a) Exoskeleton;
 - b) Supports body tissue and organs, protects inner parts, reduces water loss/ evaporation, helps in movement/ attachment of muscles;
9.
 - a) Provide mechanical strength / support/ it is a strengthening tissue;
 - b) Xylem vessels and tracheids have lignified walls; to provide support;
one is damaged man is not blinded;
10.
 - a) Tendons are structures which attach skeletal muscles to bone while ligaments are structures that hold two bones together;
 - b) Use of turgor pressure / turgidity; use of tendrils and climbing stems; tissue distribution in stems (parenchyma) sclerenchyma / collenchyma); use of xylem (thickened tracheids & vessels) ; use of spines and thorns e.g roses.
11.
 - a) i) Lignin;
ii) Phloem;
 - b) Growing areas of root, stem/ shoot, meristems ;
Storage organs – Fruits, seeds, stems, roots, leaves;
12.
 - Maintain shape of the body ;
 - Protect delicate organs of the body e.g. heart, brain;
 - Place/ area of attachment for other organs of the body;
13. Capitulum
14.
 - (a) Scapula;
 - (b) (i) Humerous;
(ii) Ball and socket joint ;

- For muscle attachment;
15.
 - a) Femur; ;
 - b) Reloic girdle/ pubis of peloic girdle;
 - c) Hinge joint;

Rj. thoracic alone or vertebra alone
 b)X-neutral spine;
 W-centrum;
 16.
 - (a) Axis;
 - (b) Fits in the neural canal of atlas to permit for turning of the head:
 17.
 - a)
 - Sclerenchyma;
 - Xylem;
 - Collenchyma;

Accept Parenchyma
 - b)
 - i) X – Biceps;
 - Y- Triceps;

Reject Flexor and Extensor

 - ii) X (Biceps) relaxes; as Y (Triceps) contracts;
 - c) Hinge joint;
 18.
 - a) locomotion enables animal to move from one place to another in search of food; mates; to escape from predators; to disperse/avoid unfavourable environments;
 - b)-have streamline body which reduces friction; the scales overlap backwards and lie flat close to the body, thus enhancing the streamline shape;
 - they have air-filled swim bladder that helps them to maintain a density that is equal to that of the surrounding water; helping the fish to float; (making forward movement easy)
 - tail fin long/has large surface area to increase the amount of water displaced resulting in an increase in forward thrust;
 - they have strong tail muscles which enable the tail to move from side to side against water;(pushing the fish to move forward)
 - the have paired pectoral and pelvic fins; which are used for steering; for bringing about downward or upward movement; as breaks//for braking; and for preventing pitching;
 - they have unpaired fins, dorsal and anal fins; which increases the vertical surface area preventing fish from rolling or yawing;
 - the fish has inflexible head which help, fish to maintain forward thrust;
 - have fleshable backbone onto which myotomes are attached; the muscles contract and relax to bring about undulation movement;
 - fish also secretes mucus which covers body and reduces friction during movement;

16. Human health

1.
 - a) *Vibrio cholerae*;
 - b)
 - i) Pig;
 - ii) Fresh water snail;
 - c) Injected by a female anopheles mosquito;
2.
 - (a) Fever;
 - (b) *Plasmodium*;
 - (c)- Uses of vaccines;

educationgroup.com

- Sleeping under treated mosquito nets
 - Getting rid of stagnant water and bushes around residential areas;
 - use of ant malarial drugs; (any 1st correct)
3. Salmonella typhii
 4. a) plasmodium parasite;
b) -drainage of pools that act as breeding grounds for mosquitoes;
 - pools that cannot be drained should be sprayed with oil or insecticides to destroy mosquito larvae;
 - fish that feed on mosquito larvae may be introduced into such pools;
 - tall grass and bushes which be cleared near human dwelling;
 - visitors to areas where malaria is prevalent should take anti-malaria drugs;
 5. (a) (i) Salmonella typhii;
(ii) Entamoeba histolytica;
(b) Malaria ;
 6. a) Protoctista;
b) Cholera;
Syphilis;
c) Use of condoms;
Abstinence;
Faithfulness to one partner;
 7. To know HIV status; so as to take appropriate measures. If positive start medication/negative avoid infection;
 8. a) malaria;
b) Amoebic dysentery/ Amoebiasis;

SECTION III- QUESTIONS
CONFIDENTIAL INFORMATION TO SCHOOLS AND PRACTICALS

KAKAMEGA CENTRAL DISTRICT

Each candidate will require the following:-

- *Solution V- sucrose laboratory chemicals*
- *Solution W – Glucose*
- *Means of heating*
- *2 test tubes*
- *Benedicts solution (10mls)*
- *Dilute HCl (5mls)*
- *Sodium hydrogen carbonate solution*
- *Access to water*
- *A dropper*
- *Measuring cylinder (to measure 10mls)*

1.
 - a) Identify solutions **V** and **W** by carrying out the food tests as indicated in the table below
 - b) Which of the two solutions **V** and **W** would you recommend for a person who needs an immediate source of energy? Give a reason for your answer.

2. The following is a diagrammatic representation of a dissection of a rabbit showing the urinogenital system

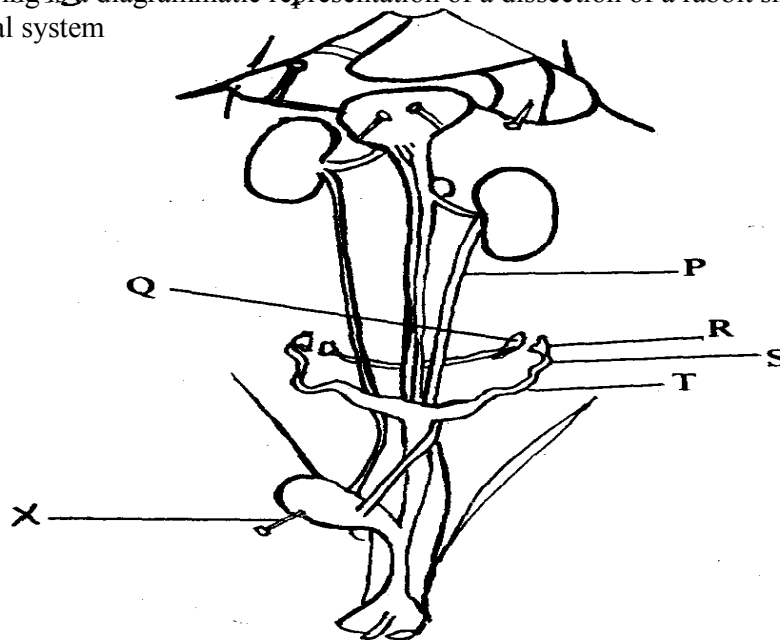

- a) In the table below, name the structures labeled **P**, **Q**, **S** and **T**. For each of the structures, state **one** function
- b) i) Identify the sex of the rabbit that was dissected
 ii) Give **two** reasons for your answer in **b(i)** above
- c) Name the instrument labeled **x** in the diagram above

3. Study the photographs below and use them to answer the questions that follow;

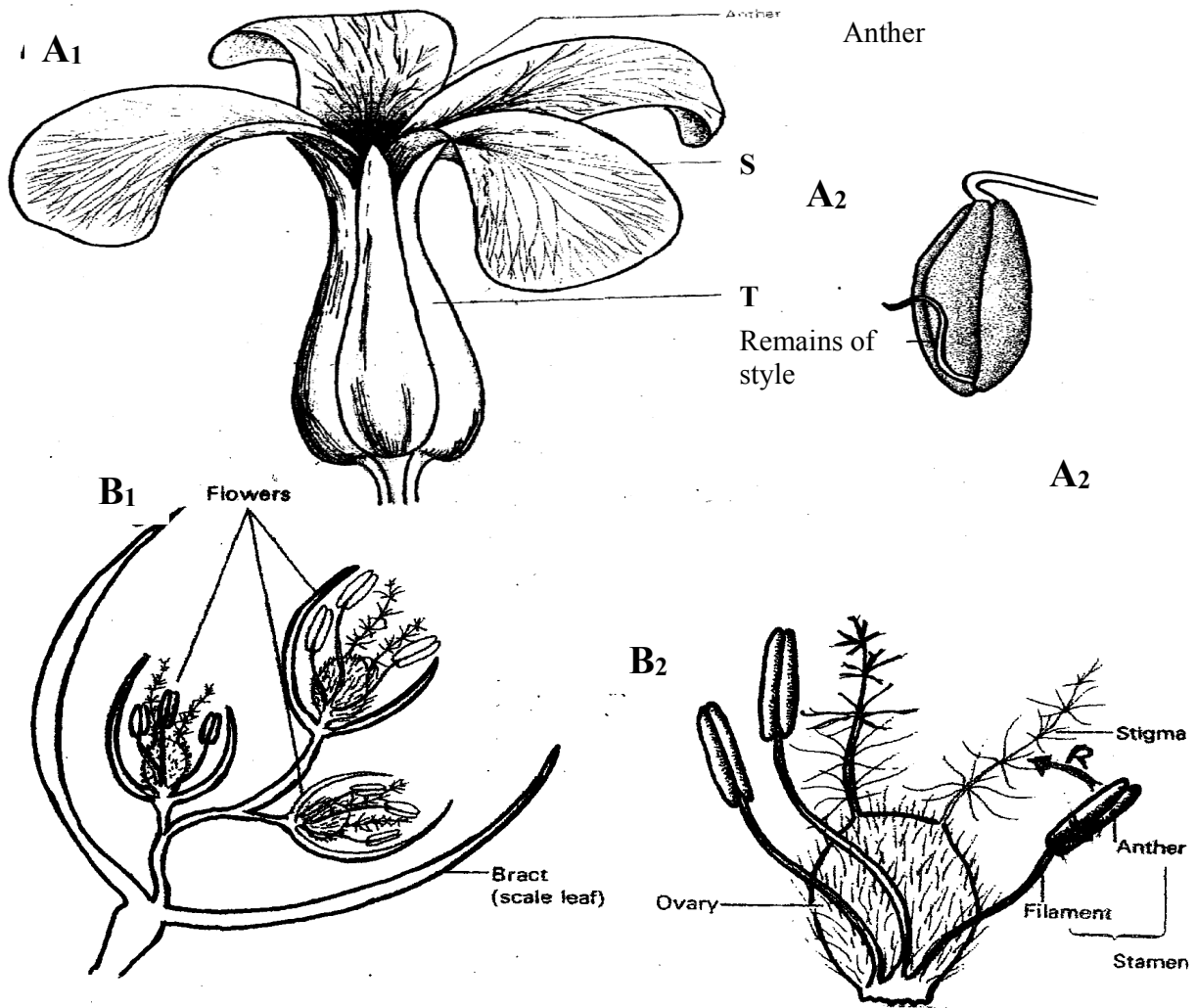

- Using the number of flowers arising from the shoot of each plant, state the flowers labelled **A₁** and **B₁**
- Name the class of the plant from which each of the flowers was obtained. Give a reason for your answer in each case :
- Name the parts labelled **S** and **T**
- What type of ovary is shown in flower **B₁**? Give a reason for your answer.
- i) Name the agent responsible for the process represented by the arrow labelled **R** in **B₂**
 - Give a reason for your answer in **e (i)** above
 - List **two** other features (not shown in the photograph) expected of such flowers as **B₁**
- i) Name an agent that brings about a similar process as the one shown by the arrow in **B₂** for **A₁**

ii) Give a reason for your answer in **f(i)** above.

g) What is the likely agent of dispersal of the specimen labelled **B₂**?

CONFIDENTIAL INFORMATION TO SCHOOLS AND PRACTICALS

KAKAMEGA EAST DISTRICT

Each candidate requires the following:-

- One large ripe tomato labelled *D₁*
- One ripe orange/lemon fruit labelled *D₂*
- 5ml DCPIP (1g of DCPIP dissolved in 1000cm³ of distilled water)
- Four clean test tubes
- Three droppers
- Scalpel blade

1. Study the diagrams **M, N, O, P** and **Q** below representing organisms in the environment and use them to answer the following questions:-

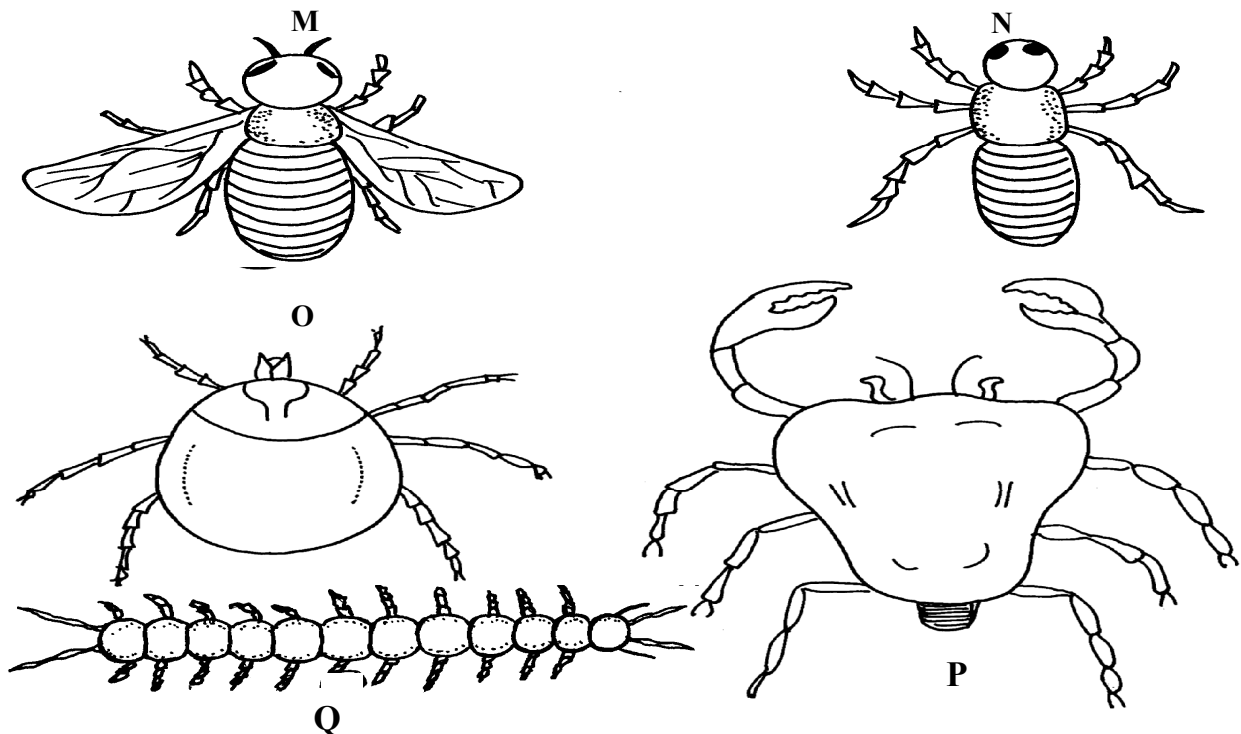

(a) With the reasons, identify the phylum to which they belong:-

(b) Identify the classes of the following organisms:-

- | | |
|---------|---------|
| M | N |
| O | P |
| Q | |

(c) Give **two** reasons for identifying the classes of organisms **M** and **P**

(d) What is the economic importance of the class to which **M** belongs?

2. You are provided with specimen **D₁**. Make a vertical (*longitudinal section through it to obtain two equal halves*)

(a) (i) Draw and label one half of **D₁**

- (ii) Calculate the magnification of your drawing (show your working)
- (iii) With reasons, identify the type of fruit **D₁**
- (b) Squeeze juice from **D₁**, into a beaker. Label two test tubes **A** and **B**. In each test tube put 1cm³ of DCPIP
 - (i) To test tube **A** add the juice drop by drop shaking well after each drop. Record the number of drops required to decolourize DCPIP in the table below.

TEST TUBE	No. of drops required to decolourize DCPIP
A	
B	

- (ii) Identify the food substance being tested
 - (iii) Which of the specimens **P₁** and **P₂** has high of the food substance being tested above?
 - (iv) What is the value of the food substance above to a growing baby?
 - (c) Boil the remaining juice extracted from **D₁** in the boiling tube for one minute and cool it. Using a dropper, add the boiled juice into another test tube labelled **B**. Containing 1cm³ of DCPIP. Record the number of drops required to decolourize the DCPIP in the table above. What is the effect of boiling the juice?
3. The diagram below represents a cross-section of a plant stem. Study it carefully and answer the questions that follow:-

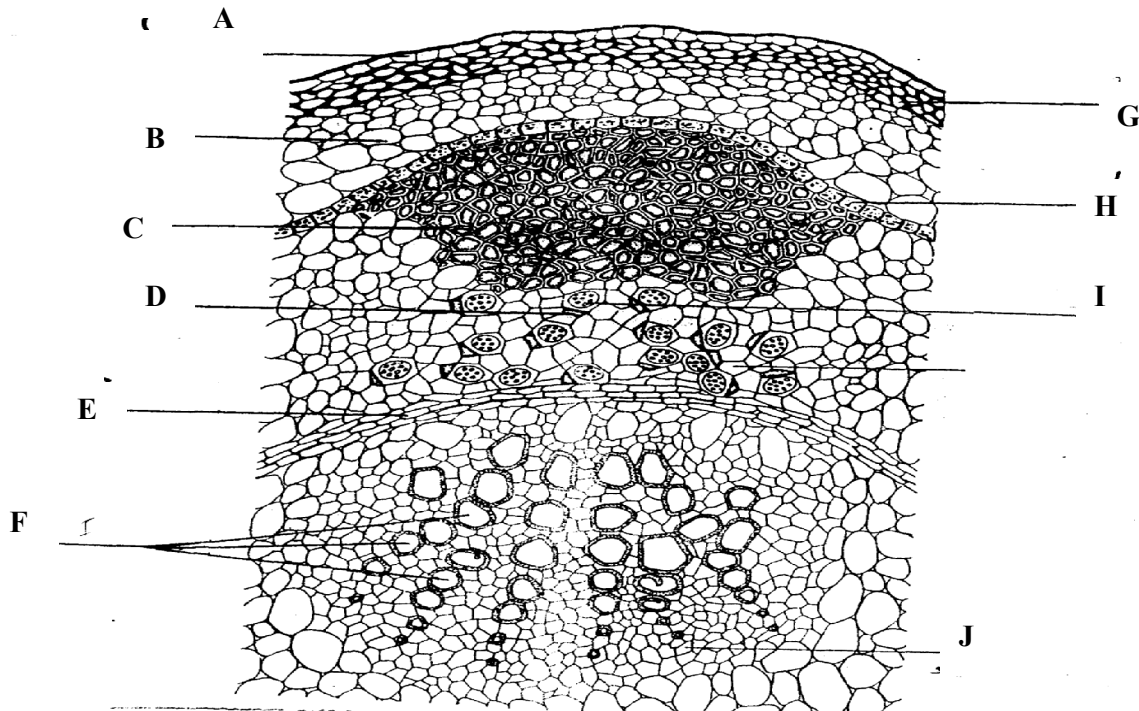

- (a) Identify letters that represent tissues responsible for support and name the tissues
- (b) State **two** ways in which the tissues named in (a) above offer support
- (c) (i) Identify the part labelled **H**
- (ii) What is the role of this part?
- (d) (i) If the plant from which the section had been obtained was placed in water containing eosin dye, which part would you expect to be stained with the dye?

(ii) Name **three** forces which help water containing this dye (eosin) to pass through the dyed tissue

(e) (i) Name the tissues labelled I

(ii) What is the name of the cell C seen adjacent to tissue I?

(iii) State the function of this cell C

CONFIDENTIAL INFORMATION TO SCHOOLS AND PRACTICALS

MIGORI DISTRICT

Each candidate should be provided with the following:

- Irish potato (one large one each – N)
- 75 ml of conc. brine labelled L₁.
- 75 ml of distilled water labelled L₂.
- Potato borers.
- Six test tubes.
- Iodine.
- Benedict's solution.
- Sodium hydroxide.
- 10% copper II sulphate.
- Means of heating.
- Means of timing.
- A ruler.

Q.1 Below are two sets of photomicrographs A and B showing various processes of cell divisions. Examine them.

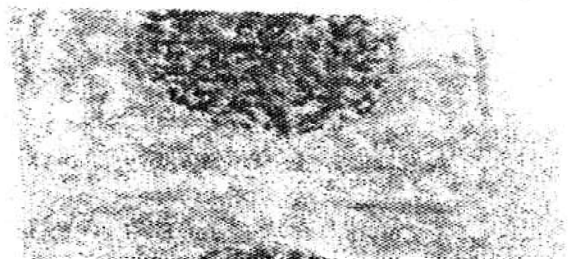
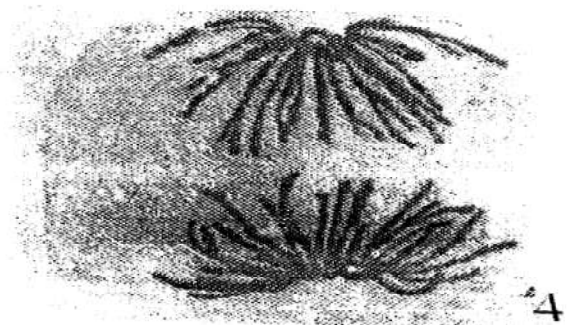
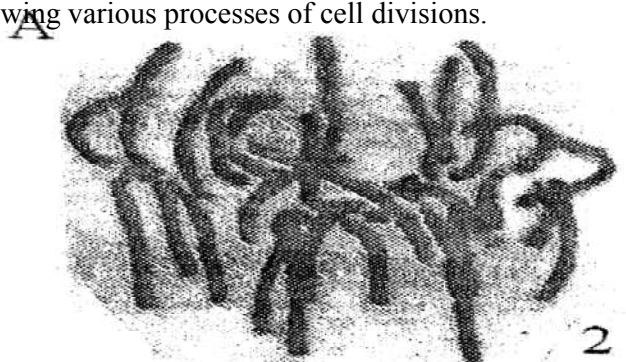
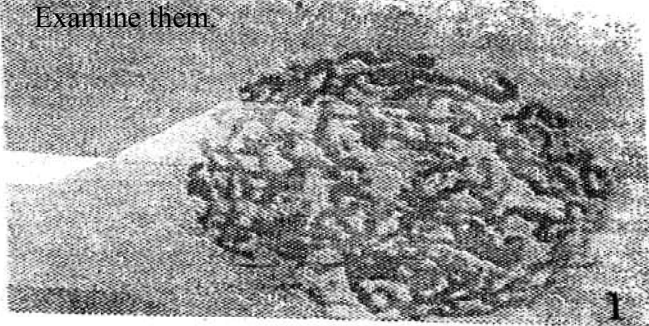

B

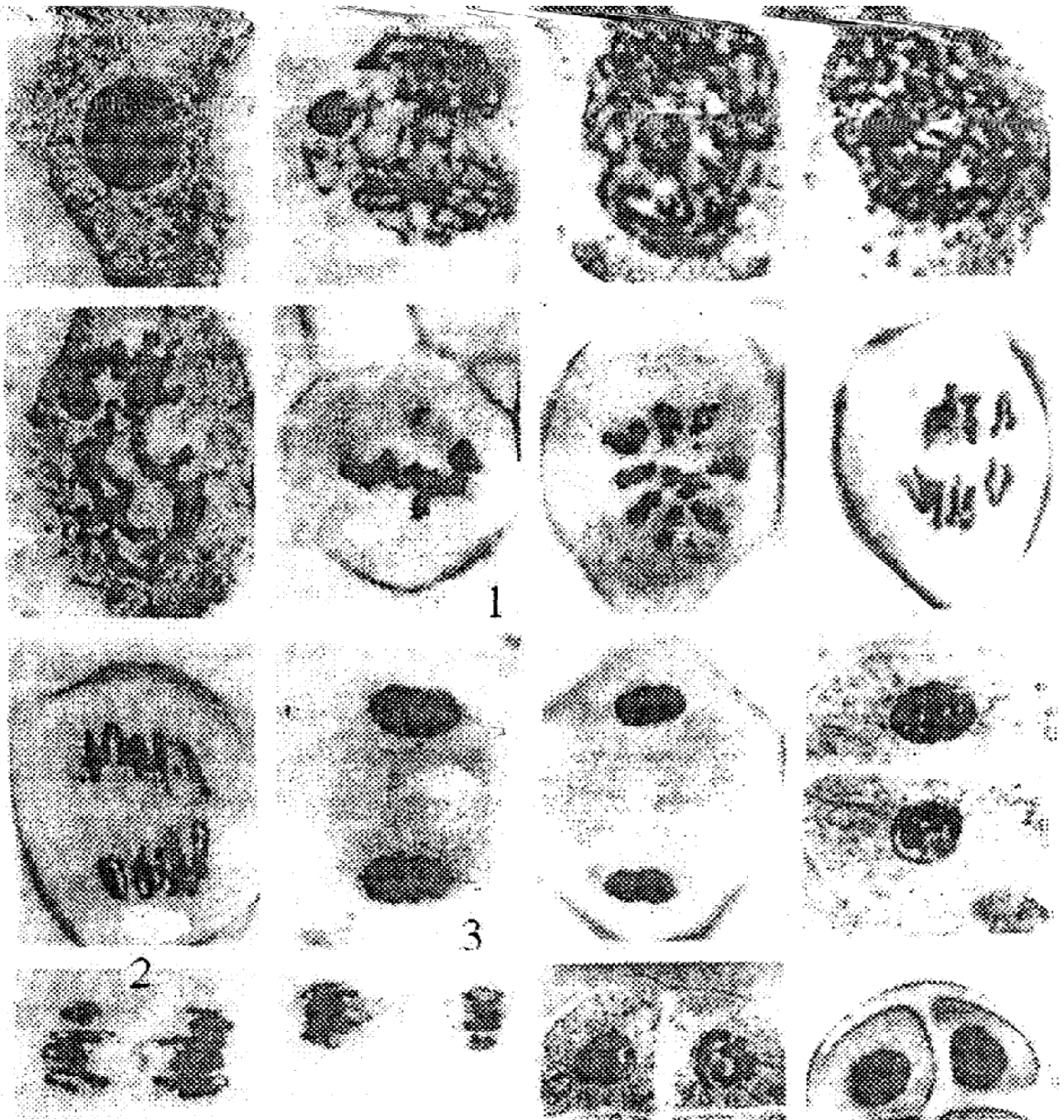

- Q. (a) Using observable features only, identify the type of cell division represented by the photomicrographs in set **A** and set **B**. Give a reason in each case.
 Cell division in set **A**
 Reason:
 Cell division in set **B**.
 Reason:
- (b) Name the division process represented by number 3 and 4 in photomicrographs of set **A** and number 1 and 3 in photomicrographs in set **B**. **Complete** the table below.
- (c) Name **one** region in higher plants where the cell division represented by photomicrographs set **A** and **B** occurs.
- (d) Describe the process that is taking place at photomicrographs set **A** number **3** and photomicrograph set **B** number **2**.
- (e) State the **importance** of each of the cell division in **A** and **B** in the bodies of living organisms.

2. You are provided with specimen **N**. You have also been provided with a cork borer bore out three (3) pieces each measuring 5 cm. Take each piece and place into the test tubes labelled **A**, **B** and **C** separately.
 Fill test tube **A** with solution labelled **L₁**.
 Fill test tube **B** with solution labelled **L₂**.
 Leave test tube labelled **C** empty (**Do not pour anything into it.**)
- (a) (i) Remove the pieces and dry each using blotting paper and measure its length. Record in the table below.
 (ii) Account for the observation made in the measurements of each piece after 30 minutes above.
- (b) (i) Crush the remaining tissue into a paste and carry out food tests on it using the reagents provided.:
 (ii) What would imbalances of such food substances cause in the diet?
 Excess of the foods.
 Deficiency of the foods.

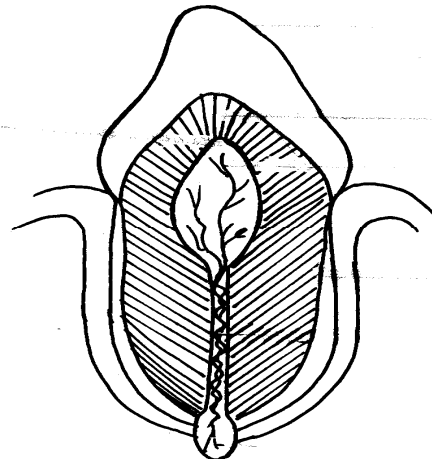

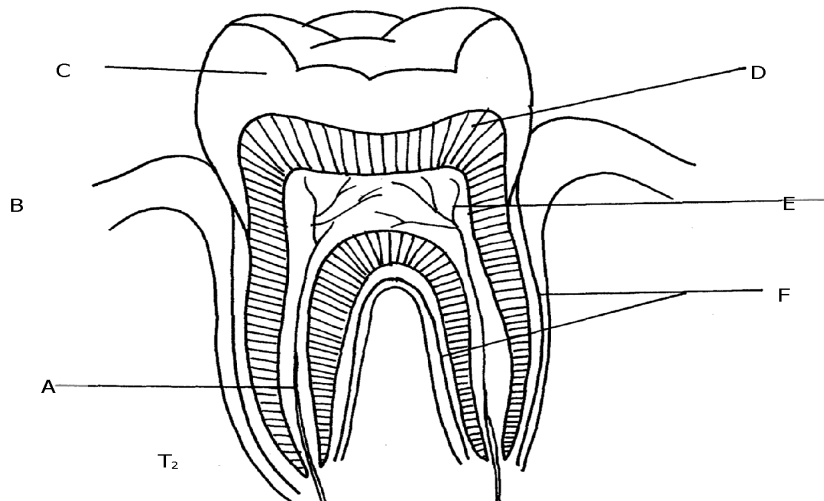

3. Study the photographs provided above and answer the questions below.
- Give the identity of **T₁** and **T₂**.
 - How is each specimen adapted to its function?
 - Label the parts of **T₂** marked **A** to **F**
 - State the effect of too much sugar in the diet on specimen **T₁** and **T₂** in humans.
 - What is the name of the gap found between **T₁** and **T₂** in herbivores.
 - State the function of the gap named in **e(i)** above.

CONFIDENTIAL INFORMATION TO SCHOOLS AND PRACTICALS

NYAMIRA DISTRICT

Each Candidate should be provided with the following:-

REQUIREMENT

- 2 Boiling tubes
- 2 test tubes
- Test tube rack
- Means of heating
- 1% copper sulphate solution
- 2M sodium hydroxide solution
- Iodine solution
- Mortar and pestle

- Scalpel
- 20% Hydrogen peroxide solution
- Fresh potato
- Droppers
- 100ml beaker

Schools should also have ordinary laboratory apparatus in addition to those listed above

1. You have been provided with specimen **Q** which is a fresh potato, liquid R (Hydrogen peroxide) and reagents 1% copper sulphate, 2M sodium hydroxide and iodine solution. Use them to carry out the tests below:
- (a) Using a scalpel, cut two small cubes measuring 1cm x 1cm from the fresh potato. Place one of the cubes in boiling water for 10 minutes, then remove the cube and let it cool. Place it in a boiling tube and label it **A**. Place the fresh piece of potato cube in another boiling tube labelled **B** and then add equal amounts of hydrogen peroxide to each test tube at the same time. Write your observations.

Observations:

- (a) (i) Boiling tube **A**
(ii) Boiling tube **B**
- (b) Explain your observations in (i) and (ii) above
- (c) Crush a small piece of the remaining potato in a mortar. Add a little amount of distilled water to make a mixture. Use it to carry out food tests below:
2. **X** and **Y** are specimens obtained from plants. Study them carefully and then use them to answer questions that follow:-

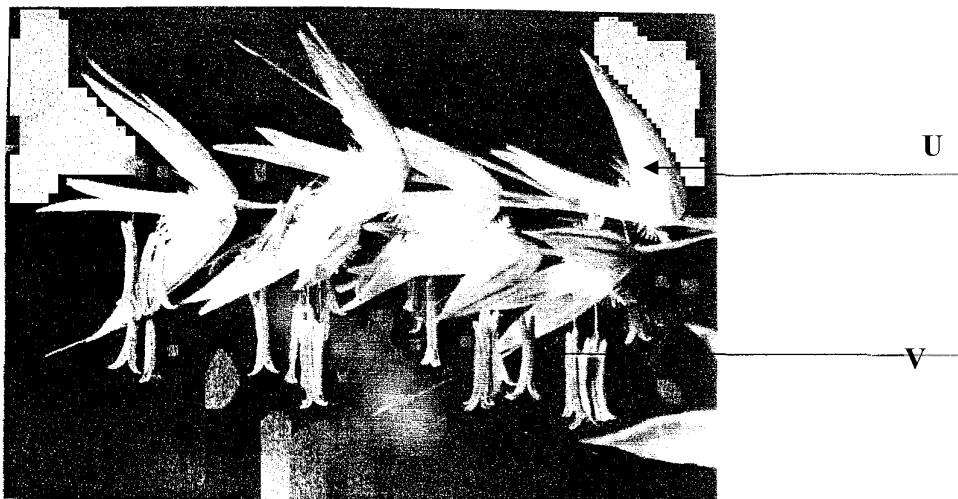



- (a) Label the parts:-
 S..... T.....
 U..... V.....
- (b) State with reasons the mode of pollination for specimen
 X
 Y:
- (c) Name the part of specimen X that develops into a fruit
3. You are provided with photographs of animals which belong to the same phylum. Study the photographs and the dichotomous key below to enable you identify the taxonomic group to which each animal belongs:-

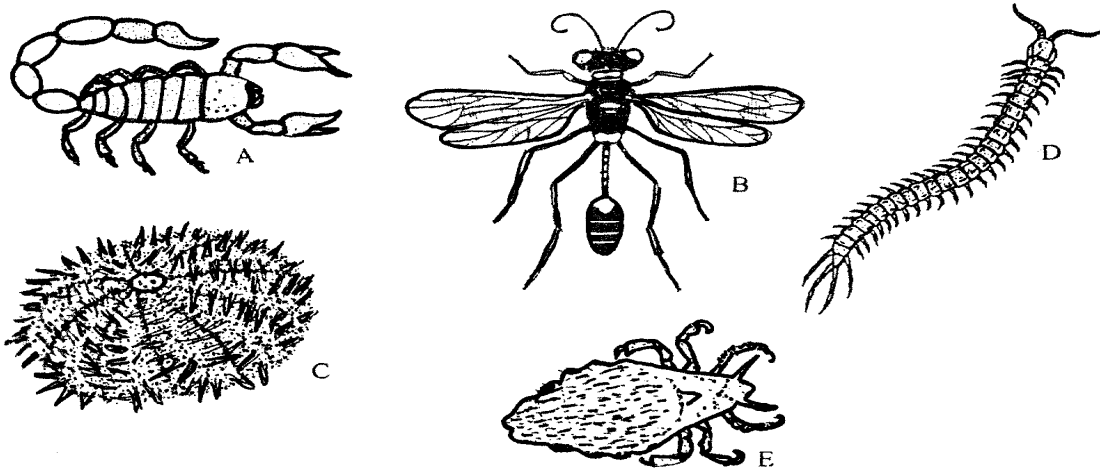

1. (a) Jointed legs presentGo to 2
 (b) Jointed legs absentGo to 7
2. (a) Three pairs of legsGo to 3
 (b) More than three pairs of legsgo to 5
3. (a) Wings presentGo to 4
 (b) Wings absent.....*Anoplura*
4. (a) One pair of wings*Diptera*
 (b) Two pairs of wings*Hymenoptera*
5. (a) Four pairs of legs*Arachnida*
 (b) More than ten pairs of legs.....Go to 6
6. (a) One pair of legs in each body segment.....*Chilopoda*
 (b) Two pairs of legs in each body segment.....*Diplopoda*
7. (a) Body partially closed in a shell*Mollusca*
 (b) Body surface has spiny projections*Echinodermata*

- (a) Using the key, identify organisms A to E giving the sequence of steps followed to arrive at the identity of each organism
- (b) (i) Using observable features only, state the phylum to which the organisms on the photograph belong:

- (ii) State **one** observable feature that enables you to arrive at the answer in **(b) (i)** above

CONFIDENTIAL INFORMATION TO SCHOOLS AND PRACTICALS

SOTIK DISTRICT – 1ST EXAM

1. *egg albumen*
Pineapple juice mixture (10ml) } labelled Z
Iodine solution
Ethanol
Distilled water
DCPIP
Benedict's solution
Source of heat (hot water bath)
Four (4) test-tubes
2. *Bougainvillea leaf –P*
Kikuyu grass leaf -Q
Hand lens
3. *Hand lens*
Freshly killed housefly
Safety pin/pair of forceps

1. (a) You are provided with the solution labelled **Z**. Using the apparatus and the reagents provided, carry out the tests for the various food substances

Food	Procedure	Observation	Conclusion

- (b) State the organ(s) which produce(s) enzyme(s) which are required to digest the contents of solution **Z** completely
- (c) Name the end products of digestion of solution **Z**
- (d) Give **two** functions of the products named in **(c)** above in the human body
2. You are provided with the specimens **P** and **Q**:
- (a) (i) What is the mode of nutrition for the organisms represented by the above specimens?
 (ii) Give a reason for your answer in **(a) (i)** above
 (iii) Write an equation for the physiological process involved in the mode of feeding in **(a)(i)** above
 - (b) Draw and label specimen **P**
 - (c) State **three** observable differences between specimens **P** and **Q**
 - (d) Name the trophic level of the organisms from which the specimens were obtained in the ecosystem
 - (e) Explain the role played by the organisms in the ecosystem
 - (f) Which features adapt specimen **Q** to enabling the organism from which it was detached to live in its habitat?
3. Using a hand lens, study the specimen provided and answer the questions that follow:

- (a) Give the phylum and the class to which the specimen belongs
- (b) State **two** characteristics which are unique to members of the class suggested in (a) above
- (c) Using the observable features only, explain how the specimen is adapted to living in its habitat.

CONFIDENTIAL INFORMATION TO SCHOOLS AND PRACTICALS

UGENYA - UGUNJA DISTRICT

Each student should be provided with the following:-

- *Onion bulb*
- *Iodine solution (5ml)*
- *Cover slip (1pc)*
- *Microscope slide (1pc)*
- *Means of labeling*
- *Hydrogen peroxide – 5ml per student*
- *Test tube (4)*
- *Distilled water*
- *Saturated sodium Chloride solution – Liquid H – 5ml per student*
- *Blotting paper (1pc)*
- *Means of timing*
- *Pestle and Mortar*
- *Piece of liver*
- *Wooden splint*
- *Benedicts solution – 5ml*
- *Scalpel blade*
- *Means of heating*
- *Boiling tube (1)*
- *Glass rod*
- *A pair of forceps*
- *Microscope (one for a group of five)*

N/B – Provide a medium power objective lens of x10 and eye piece lens of x10 or x15.

1. You are provided with a portion of an onion bulb. Remove one fleshy leaf from the onion bulb, peel the epidermis from the inner surface of the leaf and place it on a drop of iodine solution on a glass slide. Place a cover slip on the epidermis. Drain the excess iodine solution by use of a piece of blotting paper from the edge of the cover slip then leave the set up for one minute. Place a drop of **liquid H** at the edge of the cover slip. Leave the set up for **5 minutes** then drain excess liquid from the opposite of the slip using a blotting paper. Observe under medium power of the light microscope provided.
 - (a) **Draw and label** two neighbouring cells

(b) Account for the results in (a) above

(c) Using a pestle and mortar, crush two fleshy leaves of the onion bulb, add 4mls of distilled water and stir. Decant into a test tube and label the resultant filtrate as **solution J₁** and retain the residue.

Using the reagents provided, carry out food tests on **solution J₁** and fill the table below:

FOOD SUBSTANCE	PROCEDURE	OBSERVATION	CONCLUSION

(d) Label one test tube as **J₂** and another as **K**. Add 2mls of Hydrogen peroxide to each of the test tubes.

(i) Into the test tube labelled **J₂**, place the entire residue obtained in (c) above and immediately introduce a glowing splint. Record your observations in the table below. Into the test tube labelled **K**, place the piece of liver provided then immediately introduce a glowing splint into the mouth of test tube and record your observations in the table below.

(ii) Name the enzyme responsible for the reactions in the test tubes above

(iii) Explain the significance of the difference in the observations in part (i) above

2. Use the diagram provided to answer questions that follow:

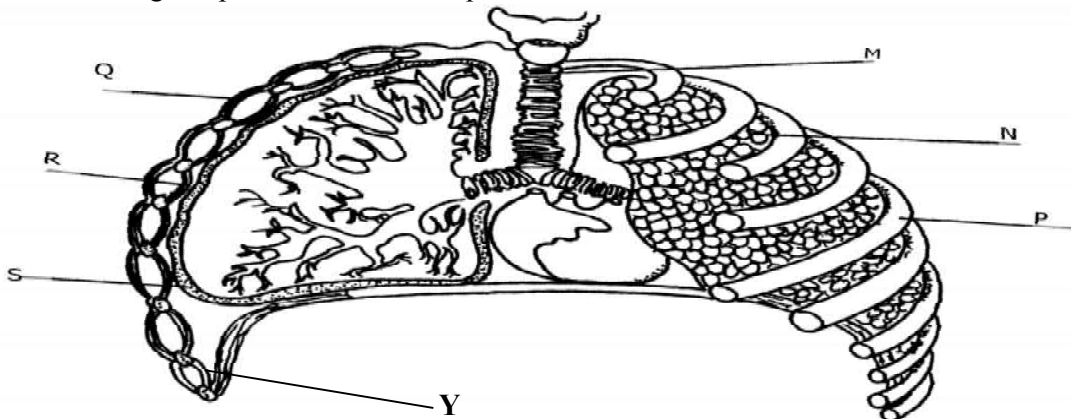

(a) Name the bones that articulate with the structure labelled **P**

(i) Dorsally

(ii) Ventrally.....

(b) Give **three** adaptations of structure **M** to its functions

(c) (i) Name the fluid found within the part labelled **S**

(ii) State the function of the fluid named in (c) (i) above

- (d) Identify the parts labelled: Q & R
- (e) State **two** changes that take place in the organ labelled N when the structure Y contracts
- (f) How is large surface area achieved for efficient functioning of the organ labelled N?
3. A student collected a number of invertebrates whose photographs appear below. He constructed a Dichotomous key as shown below to enable him place each specimen into its taxonomic group

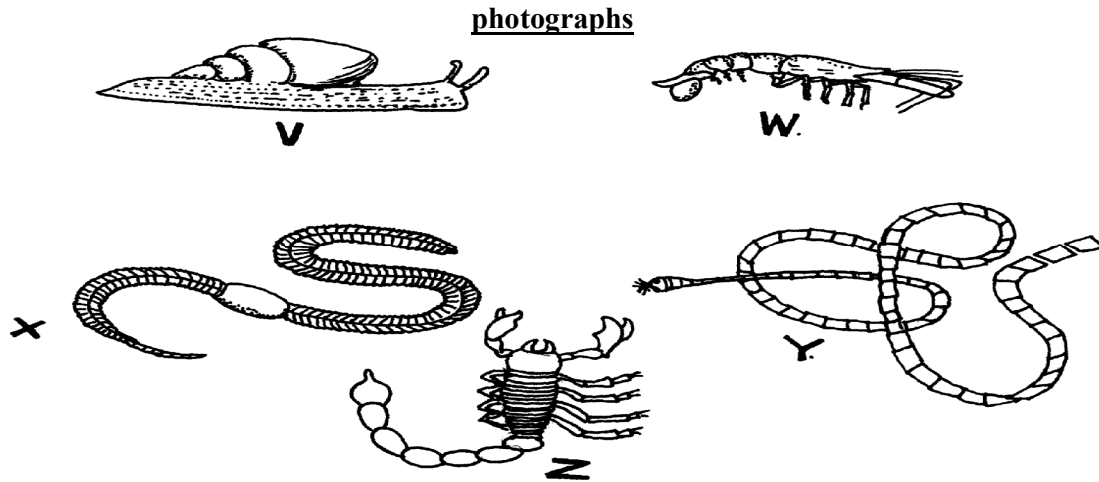

DICHOTOMOUS KEY

- | | |
|---|-------------------------|
| 1. (a) Organisms with a flat body | Go to 9 |
| (b) Organisms without a flat body | Go to 2 |
| 2. (a) Organisms having a body in a shell | <i>Mollusca</i> |
| (b) Organisms without a shell | Go to 3 |
| 3. (a) Organisms having a segmented body | Go to 4 |
| (b) Organisms with a body not segmented | <i>Nematoda</i> |
| 4. (a) Organisms having jointed appendages | Go to 6 |
| (b) Organisms without jointed appendages | Go to 5 |
| 5. (a) Organisms with a long cylindrical body | <i>Annelida</i> |
| (b) Organisms having a short stout body | <i>Trematoda</i> |
| 6. (a) Organisms with antennae | Go to 7 |
| (b) Organisms lacking antennae | Go to 8 |
| 7. (a) Organisms with a pair of antennae | <i>Insecta</i> |
| (b) Organisms with more than one pair of antennae | <i>crustacea</i> |
| 8. (a) Organisms with pincer-like mouth parts | <i>Arachnida</i> |
| (b) Organisms with sucking mouth parts | <i>Acarina</i> |
| 9. (a) Organisms having a ribbon like body | <i>Cestoda</i> |
| (b) Organisms with circular body | <i>Crinoidea</i> |

- (a) Using the dichotomous key, identify the taxonomic group of each of the five specimens shown in the photographs. In each case show in sequence, the steps in the key that you have followed to arrive at the identity of each specimen.
- (b) Name a pathogen that attacks human beings and is associated with the organism labelled V

CONFIDENTIAL INFORMATION TO SCHOOLS AND PRACTICALS

NDHIWA DISTRICT

Each candidate will require the following:-

- *Winged cockroach labelled R*
- *Tick labelled N*
- *Soldier termite labelled P*
- *Adult housefly labelled Q*
- *10ml 20 volume hydrogen peroxide*
- *Pestle and mortar*
- *Spatula preferably a wooden one*
- *Scalpel*
- *Ruler calibrated in centimeters*
- *A medium size irish potato tubers labelled L*
- *Measuring cylinder (to measure up to 4mls)*
- *2 boiling tubes*
- *3 test-tubes*
- *Means of labeling (two each)*
- *A maize seedling with opened coleoptile*
- *Green leaves and should also have remains of grain labelled K seedlings grown in the sand on trays in plastic containers give good specimens*
- *Distilled water*
- *Iodine solution*
- *Benedicts solution*
- *Means of heating*

1. You are provided with specimens labelled **N, P, Q** and **R**. Using the following characteristics and in the order given only

- Number of legs
- Presence of wings
- Number of wings

a) Construct a three –step dichotomous key. Use the given letters for identification

(Specific names not required)

b) i) Using observable features only, state the phylum to which specimen **R** belongs

ii) Give **three** reasons for your answer in **(b) (i)** above

c) i) Using observable features only, classify specimen **N** in its class

ii) Give **four** reasons for your answer in **(c) (i)**

2. Study the photographs of some hydrophytes shown below. They show various adaptations they have to overcome problems they are exposed to due to the nature of their habitats

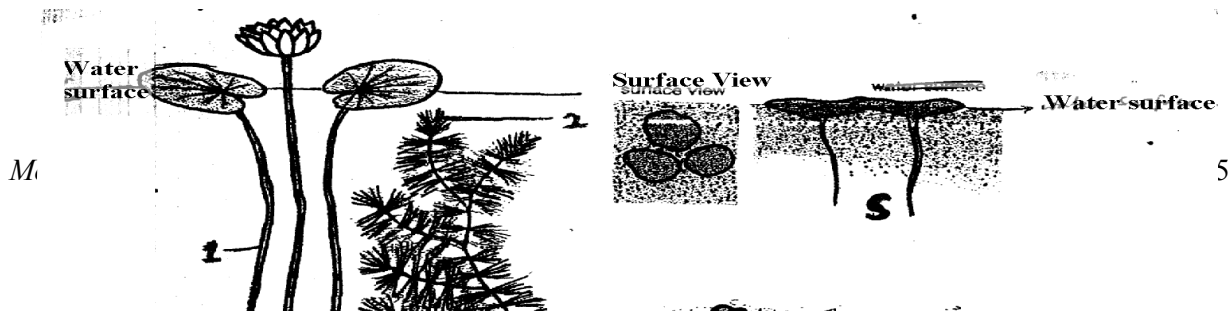

- i) What are hydrophytes?
 - ii) Name the structures of plants labelled **1** and **2**
 - iii) State **two** problems which hydrophytes are faced with in their habitat
 - iv) With reference to the photographs, how are the hydrophytes adapted to solve each of the problems you have stated in **part 2 (iii)** above?
 - v) State **two** internal adaptive features of the plants not shown in the photographs above that enables them to live in their habitat
 - vi) What type of hydrophytes do the following plants represent?
R **S**.....
3. You are provided with a specimen labelled **L** and hydrogen peroxide
- a) Cut two equal cubes whose sides are about 1cm from specimen **L**. Place one of the cubes into a boiling tube labelled **A**. Crush the other cube using pestle and mortar. Place the crushed material in another boiling tube labelled **B**.
To each boiling tube add 4ml of hydrogen peroxide
 - i) Record your observation
 - ii) Account for the result in **(a) (i)** above
 - iii) Write an equation for the break down of hydrogen peroxide
 - b) You are provided with a specimen labelled **K**. Separate the roots and leaves from the remains of the grain. Crush the roots, leaves and the remains of the grain separately. To each crushed materials add 1ml of water. Put the extract from the materials into separate test tubes and label them using the reagents provided. Test for the food substances in each of the extracts. Record the procedure, observation and conclusions in the table below:-
 - c) Account for the results obtained in **(b)** above
 - i) Roots
 - ii) Remains of grains
 - iii) Leaves

CONFIDENTIAL INFORMATION TO SCHOOLS AND PRACTICALS

MUMIAS DISTRICT

Requirements :-

- *Unripe pawpaw fruits (one pawpaw- ten students)*
- *Beaker (4)*
- *Razor /scalpel*
- *Ruler*
- *Solution G – distilled water*
- *Solution H – salt solution of different concentration namely 10%, 20%, 60%*
- *Labels*

1. You are provided with specimen **D** and two solution **G** and **H**.
 Cut five longitudinal strips of the specimen **D** peelings of approximately 0.5cm width, 0.5cm breadth and 5cm length.
 Place one strip in a beaker having solution **G**.
 Place other strips in separate beakers containing different concentration of solution **H** as indicated in the table below:

Beaker	Solution
1	Solution G
2	10% solution H
3	20% solution H
4	60% solution H

Leave the set-up for 30minutes

- (i) Record your observations in the table below:
 (b) Account for the observation in trips **1, 2** and **4**
 (c) Suggest the identity of solution **G** and **H**
2. During a biology lesson, students made drawings of invertebrates shown below. Use the dichotomous key provided below to identify the organisms;

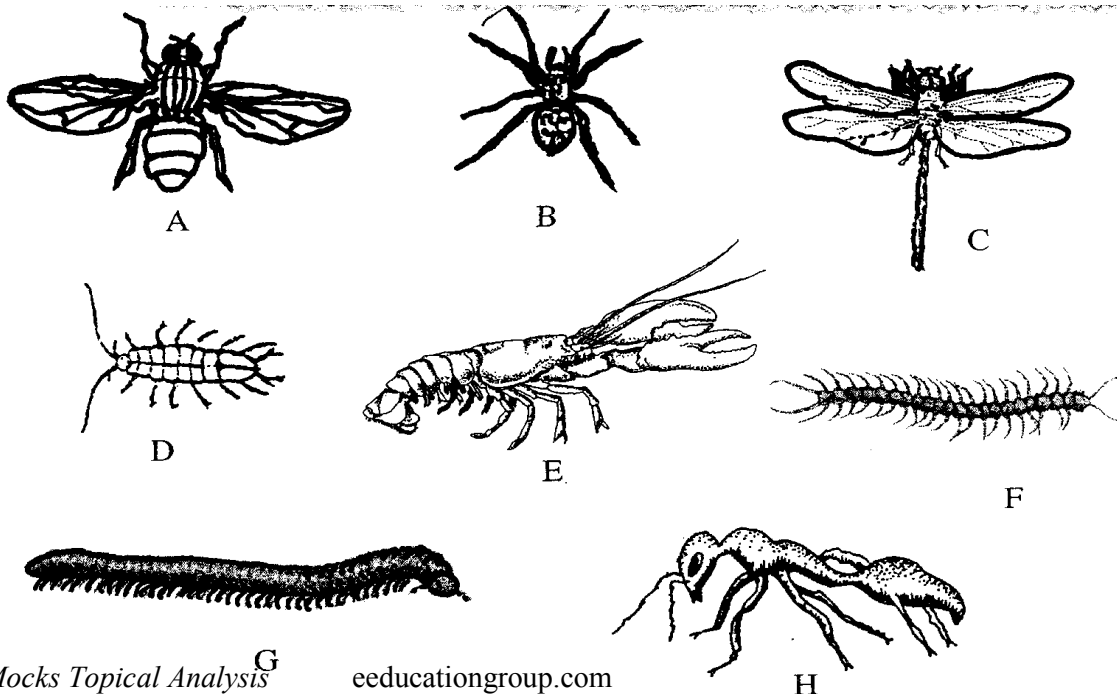

- 1. a. Animal with wingsgo to 2
b. Animal without wingsgo to 3
- 2. a. With one pair of wings.....Housefly
b. With pairs of wingsDragonfly
- 3. a. With three pairs of legsAnt
b. With more than three pairs of legs.....go to 4
- 4. a. With four pairs of legsSpider
b. With more than four pairs of legsgo to 5
- 5. a. With two pairs of antennaego to 6
b. With one pair of antennae.....go to 7
- 6. a. With six pairs of legs.....Water slater
b. With ten pairs of legsFresh water shrimp
- 7. a. With a bodymillipede
b. With a dorso-ventrally flattened body.....Centipede

(a) Complete the steps **2(b)** and **7(b)** by filling in the key above

(b) Complete the table to identify the organisms:

(c) State the classes of specimens **B, C, E** and **G**

3. The photograph **Z** below is a part of a plant. Examine it

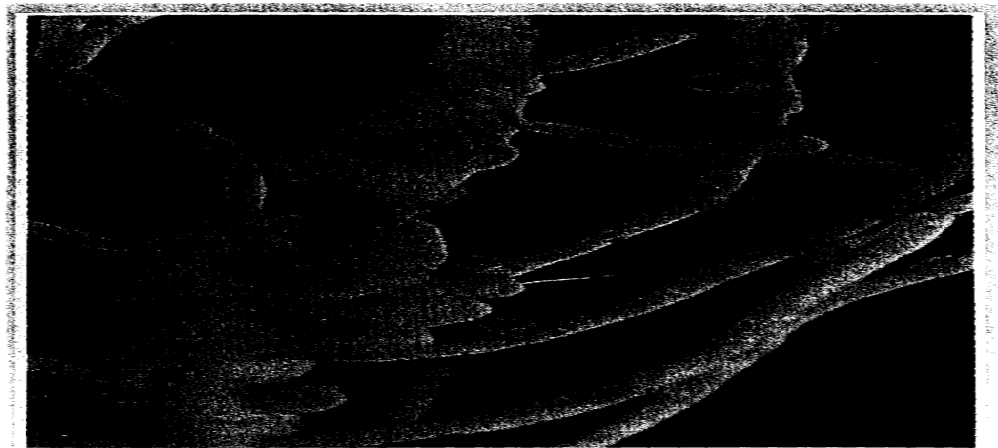

- (a) Label any **three** parts of the plant part in photograph **Z**
- (b) Name the type of organisms that is associated with this part of the plant
- (c) Photograph **Z** was taken from a special type of plant. What is the name of this group of plants?
- (d) Photograph **Z** exhibits a certain phenomenon;
 - (i) Name the phenomenon
 - (ii) State the significance of this phenomenon named in **d(i)** above
 - (iii) What is the product of this phenomenon?
 - (iv) Name **two** organisms that covert the product of the phenomenon in **d(i)** above into the raw material

CONFIDENTIAL INFORMATION TO SCHOOLS AND PRACTICALS

KISUMU WEST DISTRICT

Each candidate should have:-

- *Starch suspension labelled Liquid X*
- *Iodine solution*
- *Benedict's solution*
- *2M hydrochloric acid (1ml)*
- *2 Droppers*
- *Measuring cylinder (10ml size)*
- *Means of heating/Bunsen burner*
- *5 test-tubes*
- *Water in a small beaker*
- *Thermometer*
- *Test-tube holder*
- *3 boiling tubes*
- *Tripod stand and gauze*
- *3 labels*
- *White tile*
- *Water bath*

- *Diastase/ amylase enzyme (0.5g per student)*

N/B: -Liquid X is prepared by dissolving 5g of soluble starch in 50ml of distilled water. Thorough stirring is required whenever it is being used.

1. You are provided with liquid X and substance Q
 - (a) Place three drops of liquid X onto a white tile. Add four drops of iodine solution and record your observation.
 - (b) Pour 2ml of liquid X into a test-tube. Add equal amounts of Benedict's solution and boil the mixture. Record your observation

(c) Label three boiling tubes as set-ups A, B, and C. Place 3ml of liquid X into each of the set-ups. Divide substance Q into three equal portions.

To set-up A, add one portion of substance Q and shake.

- Place the second portion of substance Q into a test tube. Add 1ml of water to it and boil for four minutes. Add it to set-up B and shake.
- To set –up C, add the third portion of substance Q. Add 8 drops of 2M hydrochloric acid and shake.

Place the three set-ups in a warm water bath maintained at 37°C for 40minutes.

Cool the set-ups by dipping the boiling tubes in cold water

Place 2ml of the contents of each set-up into three separate test tubes. Add equal amount of Benedict's solution to each of the three test-tubes and boil.

Record your observations :-

- (d) Account for your observations in the set-ups:-
 - (e) Give the most likely identity of substance Q
 - (f) Why was the water bath maintained at 37°C
2. During a visit to a museum, students were shown some animals on display. Six of the animals are shown in the photographs below;

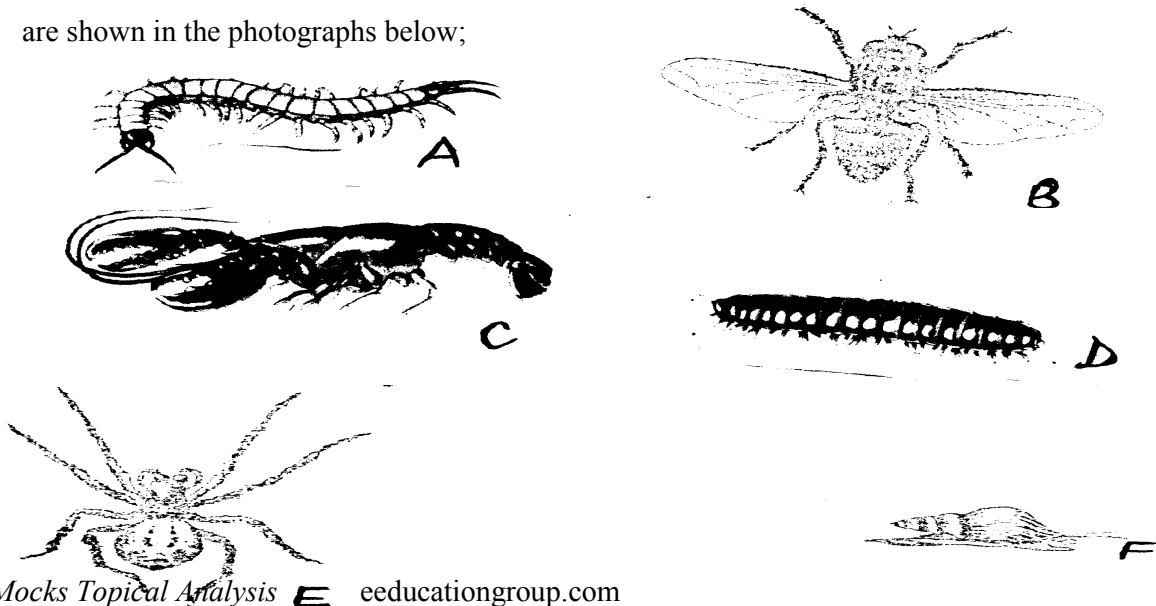

(a) Using observable features only, classify the animals, **A**, **B** and **E** into their respective classes.

Give a reason for your answer in each case

(b) State **one** morphological difference between **C** and **E**

(c) The dichotomous key constructed below can be used to identify some of the animals viewed in the museum:-

1. (a) Has jointed legsgo to 2
 (b) Lacks jointed legsgo to 3
2. (a) Has five or less pairs of legs go to 4
 (b) Has more than five pairs of legs go to 5
3. (a) Has bilateral symmetry.....EUNICE
 (b) Has radial symmetry.....LUDIA
4. (a) Has five pairs of legsCANCER
 (b) Has four pairs of legsLACTRODECTUS
5. (a) Has 1 pair of legs per body segmentSCOLOPENDRA
 (b) Has 2 pairs of legs per body segmentSIGMORIA

Use the dichotomous key above to identify animals labelled **C**, **D** and **E**. In each case show in sequence the steps followed (e.g. 1b, 2b, 3a e.t.c.) to arrive at the identity of each animal

3. Below are photographs **I** and **II** of young plants.

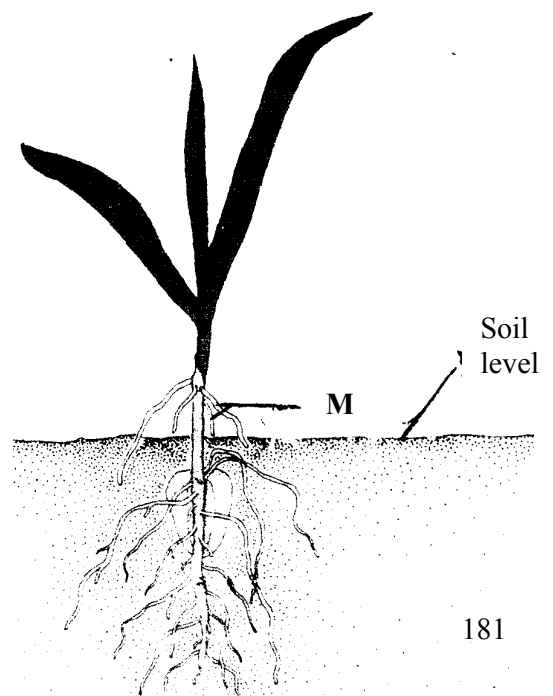
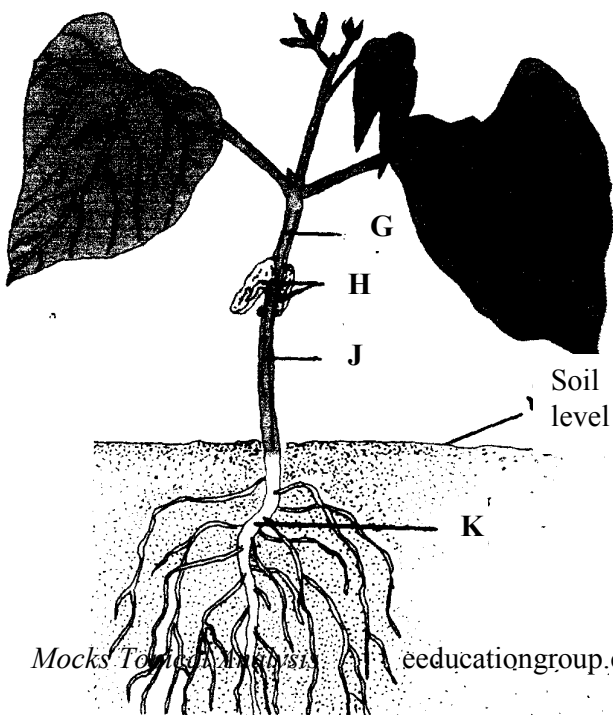

PHOTOGRAPH I

PHOTOGRAPH II

- (a) With a reason in each case, name the class to which the plants belong:
- (i) Plant in photograph I
Reason.....
- (ii) Plant in photograph II
Reason.....
- (b) Identify the parts labelled **G, J** and **M**
- (c) State **two** functions of the part labelled **H**
- (d) (i) Name the swellings that would be developed in the roots of the plant in **photograph I** later in its life
- (ii) Which organism would be found in the swellings in **(d)(i)** above?
- (e) (i) State the type of germination exhibited by the plant in **photograph II**
- (ii) Give a reason for your answer in **(e) (i)** above

CONFIDENTIAL INFORMATION TO SCHOOLS AND PRACTICALS

TRANS NZOIA WEST DISTRICT

Requirements for each candidate:

- *L₁- solution of egg albumen – 20ml*
- *L₂ – solution of starch and glucose – 20ml*
- *Visking tubing (10cm long)*
- *Thread*
- *250ml beaker*
- *Stirring rod*
- *Iodine solution*
- *Benedicts solution*
- *Source of heat*
- *4-test tubes*
- *1-boiling tube*
- *Test-tube holder*
- *Test-tube rack*

1. You are provided with liquids labeled L₁, and L₂ and a piece of visking tubing. Spare about 10ml of each of the liquids for part (a) of this question
- Using a piece of thread, tightly tie one end using the visking tubing
- Open the other end of the visking tubing and half fill it with liquid L₁. Tightly tie this end.
- Ensure there is no leakage at both ends. Immerse the tubing in a beaker containing liquid L₂

a) Using the Iodine and the benedict's solutions provided, test for the food substances in liquid L₁ and L₂. Record your observations in the table below :-

After at least 30 minutes, remove the visking tubing from the beaker and wash the outside of the tubing thoroughly to remove traces of liquid L₂

b) Using the same reagents, test for food substances in liquid L₁ in the visking tubing.

Record your observations in the table below:

c) Account for the results obtained after carrying out tests on liquid L₁ before and after immersion into liquid L₂

2. Below is photograph S

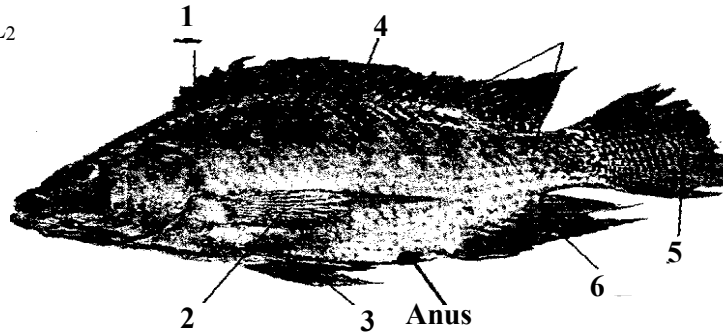

a) i) Name the class to which the organism in the photograph belongs:

ii) Give **three** observable reasons for your answer in (a) (i) above

b) State **two** functions of the part labeled 1

c) Name the fins on the specimen that:

i) Enable the specimen to balance, brake and change direction

ii) Prevent the fish from rolling and yawing

d) Measure in millimeters the length of the:

i) Photograph S from the tip of the mouth to the tip of the tail

Length..... mm

ii) Photograph S from anus to the tip of the tail.

Length..... mm

iii) Using the measurements in d (i) and d (ii) above, calculate the tails power

iv) State the significance of tail power in specimen S

e) Other than structures in (c) above, state **two** observations of the animals in photograph S to locomotion in water

3. Study the photomicrograph M which shows plants tissues

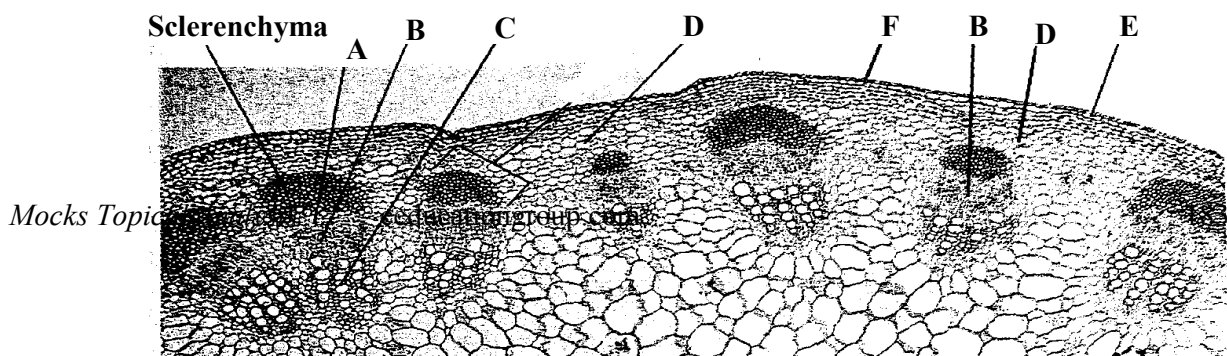

- a) Name the parts labeled **A -G**
- b) State the function(s) of tissues labeled **A, B, C**
- c) Name the cell types found in parts labeled **D** and **G**
- d) How are sclerenchyma cells adapted to their function?
- e) Distinguish between the section above and the one from the root of the same plant

RACHUONYO DISTRICT

Each school will need 20g of yeast powder for every to candidates picked and sealed in polythene

papers and labeled substance K.

To schools - Substance K is to reach school on the morning of the examination packed substance 'K' delivered to schools on the day of Biology examination

Each candidate will require the following:-

- 4 test-tubes with tightly fitting corks
- 6ml of 10% glucose in a test tube
- 3 labels per candidate
- 6ml of distilled water in a test tube
- Source of heat
- 2cm by 2cm liver piece
- Dilute hydrogen peroxide (20 volumes)
- About 2g of substance K
- Substance K to be provided by RAEC on the morning of examination day)

1. During a visit to a museum, students were shown ten specimens of invertebrates on display. The teacher provided a dichotomous key to enable them classify each specimen on display. Five of the specimens are shown in the photographs below:



E



F



G

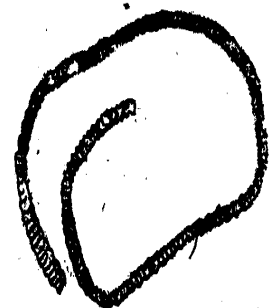

H



J



M

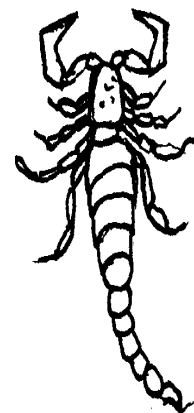

N

DICHOTOMOUS KEY

- | | |
|---|-----------|
| 1. a. Animal with flattened body | Go to 9 |
| b. Animal without flattened body | Go to 2 |
| 2. a. Animal with body in shell | Mollusca |
| b. Animal without shell | Go to 3 |
| 3. a. Animal with segmented body | Go to 4 |
| b. Animal with body not segmented | Nematoda |
| 4. a. Animal with jointed appendages | Go to 6 |
| b. Animal without jointed appendages | Go to 5 |
| 5. a. Animal with long and cylindrical body | Annelida |
| b. Animal with short stout body | Trematoda |
| 6. a. Animal with antennae | Go to 7 |
| b. Animal without antennae | Go to 8 |
| 7. a. Animal with one pair of antennae | Insecta |
| b. Animal with more than one pair of antennae | Crustacea |
| 8. a. Animal with pincer like mouth parts | Arachnida |
| b. Animal with sucking mouth parts | Acarina |
| 9. a. animal with long ribbon like body | Cestoda |
| b. Animal with circular body | Crinoidea |

- (a) Use the dichotomous key to identify the taxonomic group of each of the five specimens in the photographs. In each case, show the sequence of steps e.g. 1a, 2b, 7b e.t.c. in the key that you followed to arrive at identity of each specimen
- (b) State the phylum to which animal **G** belong
- (c) Apart from jointed appendages, state 2 other distinguishing characteristics of the phylum named in **B** above

2. The photomicrograph below represents parts of 2 adjacent cells as seen under an electron microscope. Study it and answer the questions that follow:-

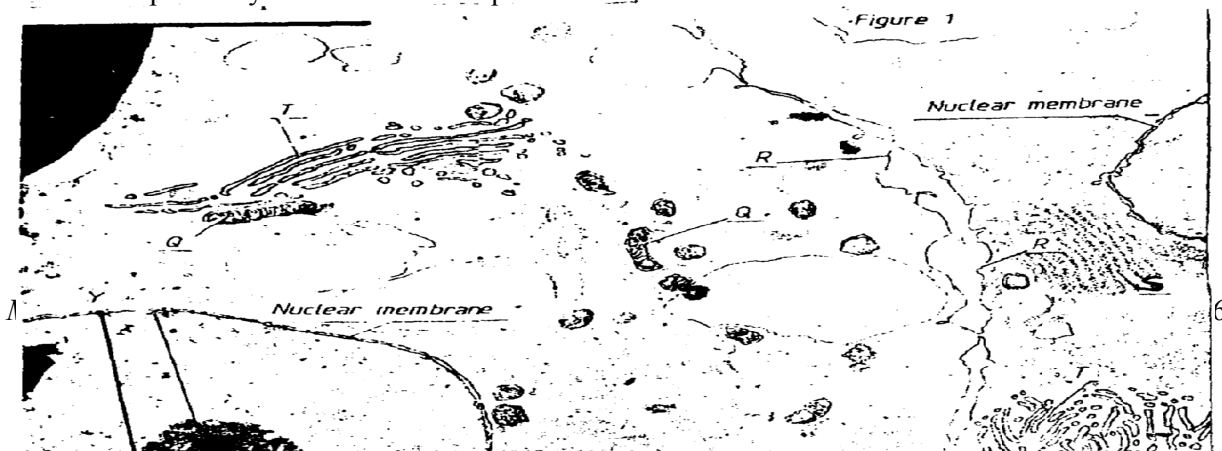

- (a) Use the table below to name **P, Q, R, S** and **T**. For each organelle, state one function
- (b) The magnification of the cells in this micrograph is $\times 10,000$. Use a ruler to measure the radius of the nucleus between **X** and **Y** in millimeters. Calculate the actual radius of the nucleus before magnification in mm

Length.....mm
Actual radius of nucleus

3. You are provided with 10% glucose solution and substance **K**. place equal amounts of the glucose solution in test tubes labeled 1, 2 and 3. Divide the substance **K** into 3 equal portions. To one portion, add 2ml of water and boil, cool it down. Pour this mixture into test tube 1 Add another portion of substance **K** to test-tube 2 and shake. Put 2ml of distilled water in test tube 3. Close the 3 test-tubes tightly using well fitting corks, and allow the set-ups to stand for at least 20 minutes
- (a) Record your observation:
 - (i) Test tube 1
 - (ii) Test tube 2
 - (iii) Rest tube 3
 - (b) (i) Name the process being investigated in the experiment
 - (ii) Write down an equation for this process
 - (iii) In which organelle does the process take place
 - (c) (i) Suggest the identity of substance **K**
 - (ii) Account for the results in test-tube 1
 - (d) Cut a small piece of liver 2cm by 2cm. drop it into the test tube containing dilute hydrogen peroxide. Leave for 2 minutes
 - (i) State your observation
 - (ii) Account for your observations

CONFIDENTIAL INFORMATION TO SCHOOLS AND PRACTICALS

KAKAMEGA NORTH DISTRICT

Each candidate to be provided with:

- Scalpel blade
- A ripe tomato labelled specimen *Q*.

- *A mortar and a pestle*
- *Filter paper,*
- *Means of heating*
- *DCPIP*
- *3 droppers*
- *50cm³ beaker*
- *4 A freshly killed soldier termite labelled specimen R*
- *4 A freshly killed maize weevil labelled specimen. S*
- *4 A hand lens.*

1. You are provided with specimen labelled **Q**. Examine it and;
- (a) (i) Name the part of a plant specimen **Q** is
- (ii) Give a reason for your answer in **(a)(i)** above
- (b) (i) Name the likely mode of dispersal of specimen **Q**
- (ii) Give **two** reasons for your answer in **(b)(i)** above
- (c) Make a transverse section through specimen **Q** to obtain two equal halves
- (i) Draw and label one of the halves of specimen **Q**.
- (ii) Crush one of the halves of specimen **Q** in a mortar using a pestle to obtain a paste. Gently decant the juice into a boiling tube.
- d) Using the reagents provided test for the food substances present in the juice extracted.
- Record your procedures, observations and conclusions in the table below.

Food substance	Procedure	Observations	Conclusion

2. You are provided with specimens labelled **R** and **S**. Examine then;
- (a) (i) Name the phylum to which the specimen **R** and **S** belong
- (ii) Give **three** reasons for your answer in **(a)(i)** above.
- (b) (i) Name the class to which specimens **R** and **S** belong
- (ii) Give **three** reasons for your answer in **(b)(i)** above.
- (c) State **two** observable differences between specimens **R** and **S**.
3. The drawings below illustrate two skulls **V** and **W** obtained from **two** different mammals. Examine them.

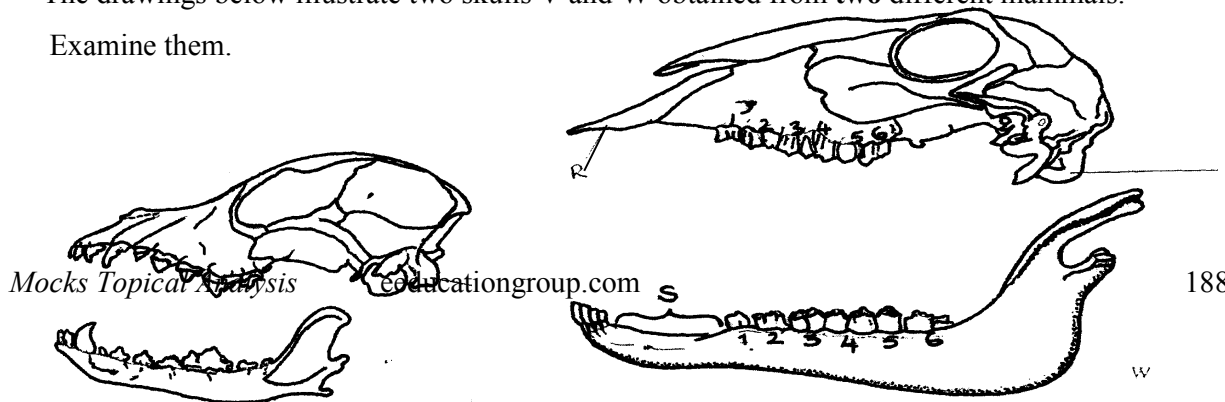

R

T

T

V

W

- (a) State the mode of feeding of the organism from which each of the skulls was obtained.
Give **two** reasons in each case.
- (b) Label canine on drawing **W** and carnassial teeth on drawing **V**
- (c) State the function of each of the following labelled parts on the drawing **R & S**
- (d) Write down the dental formula of the organism from which skull **W** was obtained
- (e) State **four** observable differences between the skulls **V** and **W**.
- (f) (i) Name the part labelled **T**
(ii) Name the vertebra that articulates with the part labelled **T**.

CONFIDENTIAL INFORMATION TO SCHOOLS AND PRACTICALS

SOTIK DISTRICT- 1ST EXAM

1. You are provided with two pieces of plant material labelled specimen Q. Using a scalpel cut two slits half way to obtain four flaps through the middle of each piece as shown in the diagram below:-

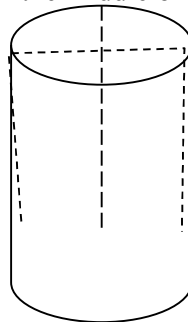

Place one piece in the solution labelled **M₁** and the other in the solution **M₂** . Allow the set up to stand for 30minutes

- (a) After 30minutes remove the pieces and press them gently between the fingers
- (i) Record your observations **M₁** **M₂**
- (ii) Account for the observations in A above
- (b) Examine the pieces

- (i) Record other observations besides those made in (a) (i) above
 - (ii) Account for the observations in (b)(i) above
2. You are provided with specimen labelled **K**
- (a) (i) Name the class to which the specimen belongs
 - (ii) Give **three** reasons for your answer in a (i) above
 - (b) What term is used to describe the shape of the specimen?
 - (c) Name and draw the fins on the specimen that;
 - (i) Enable the specimen to balance, brake and change direction
 - (ii) Prevent the fish from rolling and yawing
3. You are provided with a specimen labelled
- (a) (i) What part of a plant is specimen **T**?
 - (ii) Give a reason for your answer in a(i) above
 - (b) (i) Cut a transverse section through specimen **T** (i) Draw and label one of the cut surfaces
 - (ii) State the magnification of your drawing
 - (iii) State the type of placentation of specimen **T**
 - (c) Name the agent of dispersal of specimen **T**
 - (d) State how specimen **T** is adapted to its mode of dispersal

CONFIDENTIAL INFORMATION TO SCHOOLS AND PRACTICALS

BUTERE EAST DISTRICT

Each candidate should be provided with the following material/apparatus for the practical:-

- *Medium sized Irish potato (1 piece each) labeled Q.*
- *Mortar and pestle.*
- *Scalpel*
- *Distilled water*
- *Cotton thread (20 cm long).*
- *Visking tube 15 cm long.*
- *100 ml beaker.*
- *Stirring rod.*
- *Iodine solution.*
- *Means of timing.*
- *Photomicrographs labeled M and N.*
- *Transparent ruler graduated in mm*
- *Specimen K – Medium sized orange (should be moderately ripe and juicy)*
- *Test tubes (3 per candidate) in a test tube rack.*
- *DCPIP solution.*
- *Iodine solution.*
- *Benedicts solution.*

- *Means of heating water bath.*
- *Test tube holder.*
- *3 droppers.*
- *10 ml measuring cylinder.*

1. You are provided with a specimen labeled Q. Slice off about 2 cm thick disc from the specimen. Peel it. Place the piece into a beaker and mash it into a paste using pestle and mortar. Add 20 ml of distilled water and stir. Tie one end of the transparent visking tubing provided. Decant the extract into the tubing and tie the other end tightly. Ensure there is no leakage at both ends of tubing. Rinse the outside of tubing with water. Immerse the tubing with its contents in a 100 ml beaker containing iodine solution. Allow to stand for 20 minutes..

- a) Record your observations in the table below.
- (b) Account for the results obtained from (a) above.
- (c) What is the significance of the process being investigated to plants?

2. Study the micrographs M and N show forms of a sexual reproduction in a certain group of organisms. Study them and answer questions that follow.

- (a) (i) State the kingdom to which the two specimens belong.
(ii) Give reason for your answer.
- (b) (i) What types of asexual reproduction are represented by the two specimens?
(ii) State an example in each case of an organism that uses the type of reproduction named above.
- (c) Consider the point marked X and Y. Measure the distances between the two in cm.
 - (i) Distance _____ cm
 - (ii) If the magnification of N is x60 of the actual specimen. What is the size of the actual specimen in micrometers? (Show your working)

What is the economic importance of the activities of **M** and **N**?

3. You are provided with the specimen labeled **K**. Make a transverse section of the specimen

- (ii) How is the specimen adapted for dispersal by the agent named in c (i) above?
- (d) Squeeze the juice from the specimen **K** into a small beaker. Using the reagent provided to test for the food substances in the juice. Record the substances, procedures, observations and

CONFIDENTIAL INFORMATION TO SCHOOLS AND PRACTICALS

TRANS MARA DISTRICT

Each student should be provided with:-

1. *Specimen P – fresh piece of mammalian lungs*
Specimen Q – fresh piece of mammalian trachea
 - *Petri dishes –*
 - *A white tile*
 - *A scalpel blade*
 - *A hand lens*
 - *Ruler*
2. *Specimen R – fresh peas in a pod (Legume)*
Specimen S – An orange/lemon (ripe)

1. (a) You are provided with specimen **P** and **Q** which were obtained from the same animal.
Examine them carefully and answer the questions that follow:
 - (b) Which organ system were the specimen **P** and **Q** obtained from
 - (c) State the functions of **P** and **Q** in the organ system named in (b) above
 - (d) State **four** adaptations in each one of specimen **P** and **Q** to their functions
 - (e) Using a scalpel cut and draw a well labelled transverse section of specimen **P**
2. You are provided with specimen labeled **R** and **S**. Use them to answer the questions that follow:
 - (a) State the type of fruit labelled **R** and **S**
 - (b) (i) Draw a plan diagram of the longitudinally cut surface of specimen **R**
 - (ii) Work out your magnification
 - (iii) State the placentation of specimen **R**
 - (c) (i) State the method of dispersal of specimen **R** and **S** giving reasons for each case.
Fill your answers in the table below
 - (ii) Give **one** advantage of the method of dispersal of specimen **S** and one disadvantage of dispersal of specimen **R**.
3. You are provided with photographs of specimen **K**, **L**, **M**, **N** and **P**. using observable features only, answer the questions that follow:

Mocks Topica



- (a) (i) State the phylum of the organisms
(ii) Give **two** reasons for your answer in (a) (i) above
- (b) With reasons give the class of :
- (i) Specimen **K**
Reason
- (ii) Specimen **N**
Reason
- (c) (i) State **two** ways by which specimen **M** is adapted to locomotion
(ii) Identify the type of growth that occurs in members of specimen **M**
(iii) Name the hormone responsible for metamorphosis in specimen **M**
- (d) State **two** economic importance of specimen **P**

CONFIDENTIAL INFORMATION TO SCHOOLS AND PRACTICALS

SOTIK DISTRICT

1. *Each candidate should have one fruit of;*
- *Black jack labeled P*
 - *Tomato (ripe one – money maker variety) labeled Q*
 - *Bean/pea (mature one) labelled R*
 - *Sonchus /fleabane/dandelion labeled S*

2. Each candidate should have access to :-

- DCPIP solution
- Ethanol
- Benedict's solution
- Iodine solution
- Hot water bath
- Clean water

N/B Use clean droppers where applicable to minimize contamination of reagents.

3. Each candidate should be provided with;

- (i) 4 test-tubes in a test tube rack.
- (ii) Razor blade (or they can be asked to bring theirs).

1. You are provided with specimens labeled **P, Q, R** and **S**

- (a) State the type of fruits represented by each of the specimens
- (b) Explain how specimens **R** and **S** are adapted to their agents of dispersal
- (c) Cut the specimen **Q** transversely in the middle. Draw a well labeled diagram of the face of the cut surface of one of the halves
- (d) State the placentation of specimen **Q**

- 2. (a) Wash of the halves of specimen **Q** and place it in a mortar and grind it using the pestle to obtain its juice. Then add clean water enough to fill a test tube and shake. Then decant the juice into a clean test tube. Using the apparatus and the chemicals provided subject
- (b) Explain how digestions of the components of the food sample are digested in the ileum of a mammal
- (c) What is the importance of specimen **Q** in the human diet?

3. The photographs **W** and **Z** below are of plants obtained from different habitats

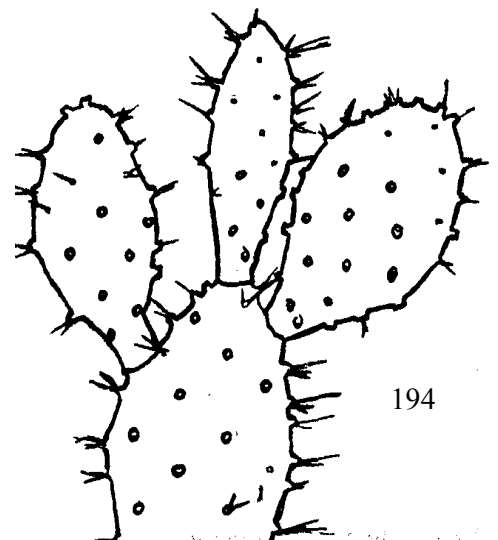

- W Z
- (a) Suggest the possible habitat of specimen W
- (b) (i) Name the structure labeled Y in specimen W
- (ii) State the function of the structure named in (b) (i) above

SECTION III- MARKING SCHEME

KAKAMEGA CENTRAL DISTRICT

1. (a)
b) Solution W;

Food substance	Solution	Procedure	Observation	Conclusion
Reducing sugar	V	To 1 ml of food substance add 1 ml of benedicts solution. Place in a warm/ hot water bath/ heat boil;	Blue colour retained;	Reducing sugar absent;
	W		Blue- green – yellow- orange; Acc – brown - final colour	Reducing sugar present
Non- reducing sugar	V	To 1 ml of food substance add 3 drops of dilute hydrochloric acid. Boil cool add sodium hydrogen carbonate till fizzing stops. Add 1 ml of Benedicts solution and place in a warm/ hot water both/ heat/ boil	Blue- green yellow- orange Acc- final colour only - brown - Reject brick red	Non reducing sugar present;
	W		Blue colour retained;	Non-reducing sugar absent

Reason – it is a reducing sugar that is absorbed directly and used in respiration to produce energy

2. a)

Structure	Name	Function
P	Ureter	Transports urine from kidney to urinary bladder
Q	Ovary	Oogenesis/ formation and release of ova i.e. ovulation
S	Fallopian tube/ oviduct	Passage of ova

T	Uterus	Pregnancy ACC implantation/ development of the embryo
---	--------	---

- b) i) Female;
 ii) – Has ovaries/ oviducts
 - Has uterus
 - has a vestibule
 - has a clitoris
- c) Dissecting pin;
3. a) A1 – solitary
 B1 – Inflorescence

b)

	Class	Reason
A1	Dicotyledonae	Has four petals
B1	Monocotyledonal	Has three stamens

c) S – Petal

T- Sepal, Accept Calyx

d) Type – superior;

Reason – above receptacle;

e) i) Wind;

ii) Feathery stigma; (to increase surface area for trapping pollen grains from the air)

iii) Small, light pollen grains

- Flower not scented;
- Inconspicuous flower; Mark first 2

f) i) Insects

ii) Tubular/ bell shaped corolla

Accept large petals

g) Animal;

KAKAMEGA EAST DISTRICT

1. (a) (i) Arthropoda; (Rej. Anthropoda/Arthropods)
 (ii) Have segmented bodies;
 - Have appendages;
 - Have exoskeleton;
- (b) M – Insecta; rej. Insects
 N – insecta;
 O – Arachnida; rej arachnids
 P – Crustacea; rej. Crustacean

Q – Chilopoda;

- (c) M – 3 pairs of limbs;
 - body divided into three parts/head thorax and abdomen);
 - Has a pair of wings;
 P – Body divided into two parts/celaphalothorax, abdomen;
 - Have carapace/hard outer shell);
 - Have two pairs of antennae;
 - Have a specialized limb for feeding/defence/chelicera; (any two marks)
- (d) – Vectors of disease causing micro-organisms /pathogens;
 - bee make honey;
 - are pollinating agents;
 - destroy timber e.g. termites
 - Crop pests e.g. weevils

2. a (i)

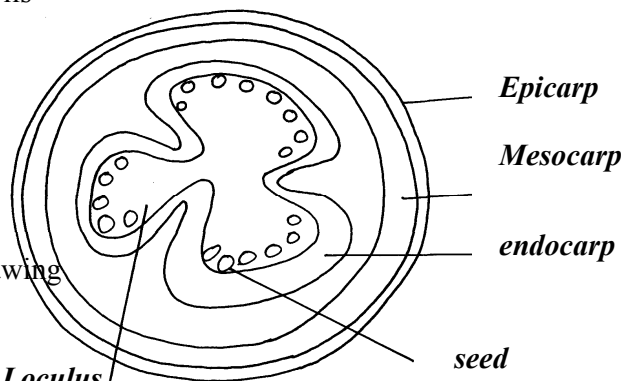

(ii) Magnification = length of drawing
 Length of image
 $\times \frac{1}{2}$ upto $\times 1\frac{1}{2}$;

(iii) Berry – many seeds
 - Endocarp fleshy/juicy; (any one)

(b) (i)

A	40;
B	Numerous Not decolourite DCPIP;

(ii) Ascorbic acid/vitamin C;

(iii) Prevents scurvy/bleeding of gums hence weak teething

(c) Boiling vapourises the vitamins/vitamin C;

3.

- (a) U – sclerenchyma
 F- xylem tissues;
 D – phloem tissues;
 AT- parenchyma tissue J
- (b) D – carry substances hence remain turgid; to offer support
 F- are strengthened with lignin;
 T- remain turgid to offer support (any two)_
 U – provide rigidity of the (2mks) stem;
- (c) (i) H – Endodermis
 (ii) Demarcates cortex from central cylinder;
- (d) (i) F;
 (ii) Root pressure;

Transpiration pull;

Capillarity/cohesion and adhesion; rej adhesive and cohesive

- (e) (i) Phloem (tissue);
 (ii) Companion cell;
 (iii) has mitochondria which provide energy for translocation n the phloem;

MIGORI / NYATIKE DISTRICT

1. (a) Set A Mitosis;
 Reason:- Two (daughter) cells formed;
 Set B Meiosis
 Reason-Four (daughter) cells formed;
- (b) A 3 Metaphase;
 4 Anaphase;
 B 1 Metaphase 1;
 3 Telophase1;
- (c) Set A – shoot tip/root tip/cambium /flower buds/apical meristems/cambium meristems;
 Set B – Anther /ovary;
- (d) Set A; number 4- Chromosome align at the equator
 Set B: - number 2: Homologous chromosomes separate and move (migrate towards the opposite poles;
- (e) Set A- Results in growth;
 Set B- Gamete formation/gamete variation
2. (i) A = 3mm;
 B = 7mm
 C = 5mm;
- (ii) A- The solution (L₁) is hypertonic to the cell sap of the potato tissue; water is drawn out of them by osmosis; the cells become plasmolysed and flaccid and they shrink /decreases in length;
 B- The solution L₂ is hypotonic to the cell sap of the potato tissue; they gain water by osmosis; and become turgid. They cause the tissue to increase in length;
- C - No change; control experiment

(b)

FOOD SUBSTANCE	PROCEDURE	OBSERVATION	CONCLUSION
STARCH	Add 3 drops iodine. Solution to food substance to be tested	Colour changes to blue-black (black)	Starch present
REDUCING SUGAR	Add on equal amount of Benedict’s solution to the food substance and heat to boil	The colour changes from blue to green to yellow to orange and brown precipitate formed	Reducing sugar present
PROTEIN	To about 2cm ³ of food substance add 1cm ³ of NaOH solution . Add 1-2 drops of copper sulphate	Purple or violet colour formed	Proteins present

- (b) Obesity;
 Marasmus in children and muscle wasting in adults

3. (a) T₁ – incisor; (tooth)
 T₂ – Molar; (tooth)
 (b) Incisor (T₁) – sharp /wedge-shaped; for cutting;
 Molar (T₂) – broad surface with cusps; for grinding
 (c) A – Nerve
 B- Pulp cavity
 C – Enamel
 D – Dentine
 E – Blood vessel
 F – Periodontal membranes
 (d) Cause bacteria to grow and produce acids which cause tooth decay;
 (e) (i) Diastema;
 (ii) Allows movement of tongue when cutting grass and turning food in the mouth

NYAMIRA DISTRICT

1. (a) (i) No gas produced
 (ii) Gas produced
 (b) (i) In boiled potato cube, enzyme catalase is denatured hence no reaction when
 (ii) Fresh potato cube had an enzyme catalase which broke/decomposed hydrogen peroxide to water and oxygen, hence production of gas.
 (c)

Food substance	Procedure	Observation	Conclusion
Starch	To fold substance add iodine solution	Blue colour formed	Starch present
Proteins	To food substance as sodium hydroxide and copper II sulphate solution	Light green mixture	Proteins absent

2. (a) S – Style
 T – Ovary
 U – Anthers
 V – Petal
 (b) X – Mode- Insect
 Reasons – Brightly coloured to attract insects.
 Anthers inside the flower to be reached by pollinating agent.
 Stigma is above the anthers to pick pollen from the incoming pollinating agent
 Y- Mode –wind
 Reasons:- Long anthers exposes outside the flower to be easily reached by the flower for pollen grain to be easily blown by wind.

3. (a)

Organism	Steps followed	Identify
A	1a, 2b, 5a	Arachnida
B	1a, 2a, 3a, 4b	Hymenoptera
C	1a, 7b	Echinodermata
D	1a, 2b, 5b, 6a	Chilopoda
E	1a, 2a, 3b	Anaplura

- (b) (i) Arthropoda
 (ii) Segmented body

SOTIK DISTRICT 2ND EXAM

1(a)

FOOD	PROCEDURE	OBSERVATION	CONCLUSION
STARCH	To 2mls of Z is added 2 drops of iodine solution	The colour of the mixture remained brown	The solution does not contain starch
REDUCING SUGAR	2ml of solution Z is mixed with 2ml of benedict's solution and heated	The colour of the mixture turned blue	Absence of reducing sugar
VITAMIN C	2ml of DCPIP is placed in a test tube and solution Z is added drop wisely	The DCPIP is decolorized loses its colour	Vitamin C is present
LIPID	2ml of solution Z is put in test tube and ethanol added until it clears then distilled water is added	White colour develops	Lipids present

NB/ -exact quantities must be mentioned
 -correct order of chemicals
 -correct colours

b) Pancreas reject pancrease

c) Fatty acids and glycerols (Reject if one is missing)

d)-can be broken down; to liberate energy; for cellular functions

-can be used to synthesize; structural components of the cell; OWTTE

2. a) i) autotrophic (nutrition)- (1mk) Reject. Antotropism
 ii) They are green hence has chlorophyll for photosynthesis;
 iii) Carbon (iv) oxide+ water sunlight $\xrightarrow{\text{Chlorophyll}}$ glucose +oxygen
 $6 \text{ CO}_2 + 6 \text{ H}_2\text{O} \longrightarrow \text{C}_6\text{H}_{12}\text{O}_6 + 6 \text{ O}_2$

NB.-chemical symbols must be correct
 -the equation must be balanced

- b) NB.-all rules for drawing apply
 -1 mark for accuracy (1x1=1mk)
 -max of 3 correctly labelled parts (3x1=3mks)

P	Q
i)has broad lamina	-has narrow lamina
ii)has hairless lamina	-has hairy lamina
iii)lamina has network of veins	-lamina has parallel veins
	OWTTE

3. a)Phylum :Arthropoda. Reject. Anthropoda/Arthropod
 Class: insecta. Reject insect
 b)-the body has 3 pairs of leg (jointed legs/6(jointed legs)
 -the body is divided into 3 clear body parts (i.e. head, thorax and abdomen)
 Reject if no mention of distinguished parts

- ACC. Any other correct feature max
- c)-has very large compound eyes; for spotting; food, enemies, mates etc
 - has (6) muscular legs; for efficient locomotion; in search of food, mates etc
 - proboscis; for efficient sucking of liquid food; OWTTE STK

UGENYA- UGUNJA DISTRICT

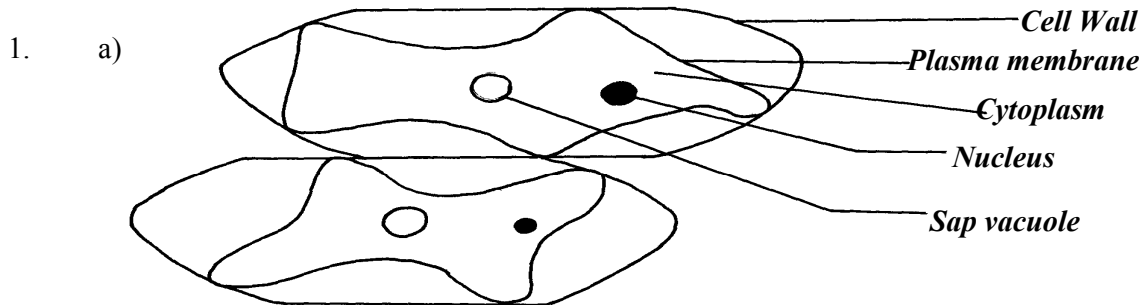

D – 1 ½ P - 1
Mag: x100 or x150 L – 4/2 CI – ½
Mag – ½

b) Liquid H is hypertonic/ highly concentrated; to cause a high osmotic pressure; water molecules are drawn from the onion epidermal cells by osmosis; excess water loss results in the plasma membrane detaching from the cell wall/ hence the cell is plasmolysed; (OWTTE)

c)

FOOD SUBSTANCE	PROCEDURE	OBSERVATION	CONCLUSION
Starch ✓	- Place 2 ml of J ₁ in a test-tube. - Add 2 – 3 drops of iodine solution. ✓ - Shake and observe.	• Solution changes from Brown to Blue-black/Black	• Starch present. ✓
Reducing Sugar ✓	- Place 2 ml of J ₁ in a test-tube. - Add equal amount of Benedict solution. - Heat to boil.	• Solution changes from blue, green, yellow then brown. ✓	• Reducing sugar present. ✓

d) i)

TEST TUBE	OBSERVATIONS
J ₂	- Glowing splint does not rekindle/ relight; or glowing splint relights /rekindles slowly; ✓1
K	- Glowing splint relights/rekindles faster; ✓1

ii) Enzyme catalase;

- iii) The liver has more catalase enzyme; since it undertakes the role of detoxification in mammals;
3. i)

ORGANISM	STEPS FOLOWED	IDENTITY
V	1b, 2a;	Mollusca;
W	1b, 2b, 3a, 4a, 6a, 7b;	Crustacea;
X	1b, 2b, 3a, 4b, 5a;	Annelida;
Y	1a, 9a;	Cestoda
Z	1b, 2b, 3a, 4a, 6b, 8a;	Arachinida;

ii) Schistosoma sp / S. haematobium / S. japonicum;

- rej. – when not underlined separately.
 - Wrong spelling.
 - Lower case “S” for 1st letter.

NDHIWA DISTRICT

1. (a) With six legsgo to 2
 (b) With eight legsN
- (a) With wingsgo to 3
 (b) without wingsP
- (a) With one pair of wingsR
 (b) With two pairs of wingsQ
- (b) (i) Arthropoda
 (ii) – Presence of exoskeleton
 - Segmented body
 - Jointed appendages/legs, limbs)
- (c) Arachnida
 - 8 legs /4 pairs of legs
 - Two body parts
 - Lack of wings
 -No antenna
2. (i) Plants which normally grow n fresh water/plants which normally grow in very we places
 (ii) Part 1 – leaf stalk
 part 2 – leaves
 (iii) - Low O₂ concentration
 - Low light intensity

- Low mineral salt concentration content
 - A lot of water
 - Waves and currents
 - (iv) – Some (emergent) have broad leaves with numerous stomata on the upper surface to increase transpiration
 - Highly dissected leaves to increase surface area for absorption of maximum light CO₂ for photosynthesis and gaseous exchange
 - - Flowers are raised above the water to allow pollination
 - - Some (floating) have log fibrous roots to absorb mineral salts
 - - Long leaf stalk to expose the eaves above water for photosynthesis
 - (v)
 - Many stomata on the upper surface to increase transpiration
 - Numerous and sensitive chloroplasts that photosynthesize at low light intensity
 - Large air filled issues /aerenchyma for buoyancy and gaseous exchange (store O₂ for respiration)
 - Poorly developed vascular bundles to discourage water absorption
 - (vi) R -Submergent
S- Floaters
3. (a) (i) A - less/few bubbles/slow effervescence/fizzing/froth/foam
B- Rapid fizzing / bubbles
- (award 1mk for bubbling /effervescence in both A and B- Reject if bubbling only appears in either A or B)
- (ii) Large surface area in B than in A for enzymatic activity in
 o Part (iii) tied to (i)
 o Bubbles due to enzymatic activity (award only 1mk)
 Hydrogen Peroxide water + Oxygen
 o Chemical symbols alone or words alone
 - Wrong enzyme, means wrong commitment
 Accept: -H₂O₂ + catalase → H₂O O₂ + Catalase

(b)

	Procedure	Observation	Conclusion
Roots	Add one 2/3 drops of iodine (soln.) Accept add iodine or any other measurements	No color change/colour of iodine / brown /yellow colour	Starch absent
	To 1m of extract , add 1/2ml /equal amounts of	Blue to green	Traces of reducing sugars
	Benedict's solution heat to boil	Yellow – orange/brown	Reducing sugar present ICCP simple sugar
Remains of grains	Add drops of iodine		Starch present
	Add drops of Benedict's solution	Green to yellow to orange/brown	Reducing sugar present
Leaves	Add iodine	No change	Starch absent
	Add Benedict's	- Green to yellow to orange to brown	Reducing sugars present

rej. – if for starch is written under procedure

- brick red

- (c) Roots- Presence of reducing sugars translated from the remains of grain/as leaves; for provision of energy /respiration/growth & development /metabolic activities e.g. active transport; ✓
 - Absence of starch because roots are not storage organs.

Remains of grains

- Presence of reducing sugars translocated from the leaves/ hydrolyzed starch;
- Presence of starch because grain is a storage organ/some starch had not been hydrolyzed for germination /growth; ✓

Leaves - Presence of reducing sugars due to photosynthesis;

-Absence of starch because reducing sugars has not been converted to starch; ✓

MUMIAS DISTRICT

1. a) Observations

Strip in beaker	Observation
1	Inside of the peeling curves outwards
2	Remained straight
3	Inside of the peeling inwards
4	Inside of the peeling curves inwards, more than in 3

b) Accounting for 1, 2 and 4

1: The cells of the inside of the peelings have cell sap which is hypertonic to solution S; hence draws in water by osmosis; and (swells up to) become turgid; leading to more increase in length of that side and curvatime on peeling sides

2: The cells of the inside of the peeling have cell sap which is atomic solution H; hence no net osmosis

3: The cells of the inside of the peeling have cell sap which is hypotonic to solution H, and lose water by osmosis to become flaccid; this side shrinks hence curvature inwards

c) Solution G – Distilled water

Solution H – Concentrated solution

2. a) steps

2b – two

7b- cyndrical

b)

specimen	steps	Identify
A	1a, 2a	Housefly
B	1b, 3b, 4a	Spider
C	1a,2b	Dragon fly
D	1b, 3b, 4b, 5a, 6a	Waters/ ater
E	1b,3b, 4b, 5a, 6b	Fresh water shrimp
F	1b, 3b, 4b, 5b, 7b	Centipede
G	1b, 3b, 4b, 5b, 7a	Millipede
H	1b, 3a	Ant

c) Class

B Arachnida

C Insecta

E	Crustacea
G	Diploda

3. a) Legume stem;
 Roots
 Nodule
- b) Rhizobium bacteria bacteria/ nitrogen fixing bacteria
- c) Leguminous plants
- d) i) symbiosis
 ii) Rhizobium bacteria which lives in the root nodules of leguminous plants fix free nitrogen in the soil into nitrates ; which are absorbed by plants to make plant proteins; bacteria benefit from shelter and carbohydrates provided by the plants; this relationship enables plants to thrive on nitrogen deficient soils
 iii) Nitrate
 iv) Pseudomonas denitrificans
 Thiobacillus denitrificans

KISUMU WEST DISTRICT

1. (a) Blue black/black dark blue colour is formed
 (b) No colour change/colour of Benedict's solution remains;
 Rej: No change /no reaction/ no observation /nothing happens
 (c) Set-up A- colour changes from blue to green to yellow to orange/brown;
 Set-up B: No colour change/ colour of Benedicts' solution remains;
 Rj- No change/no reaction/no observation/nothing happens
 Set-up C- No colour change/colour of Bendict's solution remains;
 Rj- No change /no reaction/ no observation/ nothing happens
 (d) Set-up A – Enzyme amylase/diastase/invertase (in Q); digests /hydrolisis/breaks down/ converts starch (in liquid X); to reducing sugar/maltose;
 Set-up B: boiling denatures/destroys enzymes amylase/diastase/invertase; henc starch is not converted to reducing sugar/maltose;
 Set up C:- Hydrochloric acid provides unfavourable PH for enzyme amulase diastase/invertase; hence starch is not converted to reducing sugar/maltose;
 (e) Enzyme amylase/diastase/invertase;
 (f) To provide optimum temperature for reaction of enzyme amylase/diastase;
2. (a) (i) Chilopoda; Rj wrong spellings of classes but award marks for reasons
 Reason – One pair of legs per body segment;
 -Dorsoventrally flattened body; (consider first one only)
- (ii) Insecta;
 Reason- Body is divided into three parts/regions;
 - Three pairs of legs;
 - presence of wings;
- (iii) Arachnida;

Reason:- Four pairs of limbs/legs;

C _____ E

- | | |
|-------------------------------|--------------------------|
| - 5pairs of legs | 4Pairs of legs |
| - Has antennae | Lacks antennae |
| - Lacks chelicerae /pedipalps | Has chelicerae/pedipalps |
| - Has carapace | Lacks carapace |

(c)

ANIMAL	STEPS FOLLOWED	IDENTITY
C	1a, 2a, 4a;	CANCER;
D	1, 2b, 5b;	SIGMORIA;
E	1a, 2a, 4b;	LACTRODECTUS;

3. (a) (i) Dicotyledonae; Rej; wrong spellings of classes

Reason: - Net-veined leaves

- Tap root system; Rj: tap roots (Mark first one)

(ii) Monocotyledonae;

Reason :- Parallel –veined leaves;

-Fibrous root system; Rj – Fibrous roots (mark first one)

(b) G – Epicotyl; Rj wrong spellings

J- Hypocotyl;

M – Prop roots;

(c) Stores food during germination

- turns green and carries out photosynthesis;

(d) (i) root nodules;

(ii) Rhizobium bacteria

(e) (i) Hypogeal germination;

(ii) Cotyledon remains in the soil;

TRANS NZOIA WEST DISTRICT

1. a)

Liquid	Food substance	Procedure	Observation	Conclusion
L1	Starch	To 2ml of L, in a test tube add a few drops of iodine solution; Reject if heating is done	No observable color change	Starch absent

	Reducing sugar	To 2 ml of L, in a test tube add an equal amount of Benedicts solution and heat/ immerse in a warm water bath	No observable color change	Reducing sugar absent
L2	Starch	To 2 ml of L in a test tube add a few drops of iodine solution	Color changes to blue-black	Starch present
	Reducing sugar	To 2 ml of L add an equal amount of Benedicts solution and heat/ immerse in a water bath	Color turns from blue – green – yellow – orange/ red	Reducing sugar present

b)

Food substance	Procedure	Observation	Conclusion
Starch	To 2 ml of L, in a test tube add a few drops of iodine solution	No observable color change	Starch absent
Reducing sugars/ simple sugar	To 2 ml of L in a test tube add an equal amount of Benedicts solution and heat/ immerse in a warm water bath	Color turns from blue – green – yellow to orange/ red	Reducing sugars present

For procedure and food substance mark once

- c)
- On immersing the visking tubing containing L1 into solution L2, a concentration gradient was created
 - The reducing sugars/ simple sugars in L2 moved by diffusion; through the visking tubing into L1, due to their small size; hence their presence in L1, at the end Starch absent in L1, because the molecules are too large to pass through the tiny pores of the visking tubing

2. a) i) Pisces; Rejct Pieces/ fish
 ii) - Presence of scales
 - Presence of fins

- Presence of operculum
 - b) - Protection of gills
 - Gaseous exchange
 - c) i) 2 / pectoral fins
 - 3 / pelvic finsii) 4 / dorsal fin
 - 5 / caudal fin
 - 6 / anal/ ventral fin
 - d) i) 64 mm
 - ii) 29-30 mm
 - iii) Length from anus to tip of tail = $\frac{30}{29}$ = 46.9% / 45.3%
 - Length from tip of mouth to tip of tail = 64% must be there to score
 - iv) The high tail power creates enough force to enable the fish to push forward
 - e) - Streamlined body for easy movement/ reduce water resistance
 - Scales on the body overlap facing the posterior end for easy movement/ to reduce resistance from the water
 - Massive head prevents the fish from being deflected from its path when swimming
3. a) A- Phloem
B. - Vascular cambium
C. - Xylem
D. - Cortex
F. - Collenchyma
G. - Epidermis
H. - Pith
- b) A – Trans location
B – Divides to give rise to new tissues (for secondary growth)
C – Transport of water; and mineral salts
- c) Parenchyma
- d) - Cell wall thickened with lignin; for strengthening/ mechanical support
- e)

Root	Stem
------	------

Star- shaped Xylem with phloem in the arms	Vascular bundles arranged in a ring
No pith	Pith present
Presence of root hairs	Absence of root hairs

RACHUONYO DISTRICT

1. a)

ANIMAL	IDENTIFY	STEPS
E	Mollusca	1b, 2a
H	Annelida	1b,2b,3a,4b,5a
J	Cestoda	1a, 9a
M	Insecta	1b,2b,3a,4a,6a,7a
N	Arachnida	1b,2b,3a,4a,6b,8a

Each correct identify 1mk

Each correct step 1mk

Reject wrong order of steps

Reject wrong spelling for identify

Identify tied to steps (if steps is wrong then reject identity)

b) Arthropoda ✓ 1mk Rj wrong spellings

c) Segmented body ✓ Exoskeleton (made of chitin) ✓

2. a)

ORGANELLE	NAME	FUNCTION
P	nucleolus ✓	Manufacture ribosomes
Q	Mitochondrion ✓ Acc.mitochondria	Site for respiration ✓
R	Cell membrane/plasmolemma/ ✓ plasma membrane	Control entry and exit of ✓ material into cell
S	Rough endoplasmic reticulum ✓	Transport proteins ✓
T	Golgi body/apparatus ✓	Packaging and transport of glycol Proteins ✓

Rj. Wrong spelling for name but mark function of right

b) Length – 31mm

c) actual radius = photomicrograph length

Magnification

= $\frac{31}{10,000}$ ✓

= 0.0031mm ✓

3. a) i) No bubbles/no effervescence/no observable change
 ii) Bubble/effervescence/foam/increase in warmth
 iii) No bubbles/no effervescence/no observable change
- b) i) fermentation (anaerobic) respiration
 ii) $C_6H_{12}O_6 \longrightarrow 2C_2H_5OH + CO_2 + \text{Energy}$
 Glucose \longrightarrow ethanol + carbon (iv) oxide + energy
 iii) mitochondrion/mitochondria
- c) i) yeast/enzyme/catalyst (
 ii) Boiling denatures yeast/enzyme; hence glucose not broken down/respired; to produce Carbon (IV) oxide gas (which forms bubbles)
- d) i) bubbles/effervescence/foam
 ii) Catalyst (in liver); breaks down hydrogen peroxide; to form water and oxygen (which forms bubbles);

SOTIK DISTRICT – 1ST EXAM

1. (a) (i) M₁ – stem firm/hard/stiff/rigid/tough
 M₂- stem soft/flexible/flabby Reject flaccid/weak
- (ii) Solution M₁ is hypotonic (to cell sap) /cell sap is hypertonic (to L₁)
 Solution M₁ is less concentrated/more dilute than (cell sap; hence water moved into the (stem) cells/osmosis occurs; cells become turgid
 M₂- Solution M₂ is hypertonic/more concentrated than cell sap more dilute/cell sap more dilute/ cell sap less concentrated (than L₂); water moves out of the cell/osmosis occurs; makes the cell flaccid
- (b) (i) M₁ (slit opens wider/widens/strip separates; and the bends/outwards or backwards or curved; M₂- strips) remains closed together/slits remains closed/strips shrinks or shrunk;
- (ii) In M₁ cells in inner surface/cut surface /cutical cells enlarge more/; because they took in more water (by osmosis) than outer cells /outer surface/epidermal surface (which have cuticle) OR
 M₂ Cells of inner surface/cut surface/cutical cells shrunk; because they lost more water

(by osmosis) than outer cells/epidermal cells which have cuticle

N/B mark only once i.e. for M₁ or M₂

2. (a) Pisces reject- spelling mistakes

- Pisces/fish or pisces(fish)

(ii) Presence of scales

- presence of fins

- - presence of lateral line

o -presence of gills

o Presence of operculum

(i) is tied to (ii), so if (i) is wrong reject reasons even if correct

(b) Streamlined;

(c) (i) pectoral fin
right identity-

Right drawing-

pelvic fin

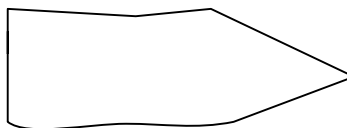

N/B - Reject wrong drawing if identity is wrong

- Reject wrong fins among the right ones

- The shape should be continuous

- Accept spines are single lines e.g.

(ii) Dorsal fin

N/B- Spines must be present to award a mark

Anal fin(Ventral fin)- Right identity-
-drawing

Caudial (Tail fin) N/B- The identity must be correct to award drawing mark

3. (a) (i) Fruit;

(ii) Two scars/point of attachment at receptacle and to the remains of style;

(b) (i) Drawing -3maks Mark clockwise

Label $5/2 = \text{max } 2$

drawing mark 1

Given when there is continuous double outline of epicarp

drawing mark 2

Given when endocarp with seeds is present

loculi with juice sac is present

drawing mark 3

When placenta is centrally located and not shaded

- (b) (ii) $x \frac{1}{2} - x 3$; N/B Reject X , x signs
 (iii) Axial/Axile/Central; Reject mistakes- free central
 (c) Animal, accept- man, human being

Reject- human alone, animal dispersal

- (d) - Seeds are hard/slimy/slippy (coat) to prevent digestion;
 - It is scented /sweet smell to attract the agent;
 - It is brightly coloured to attract the agent;
 - It is succulent / juicy to attract the agent; Mark any three correct

BUTERE EAST DISTRICT

1. a)

	Extract Inside tubing	Iodine solution outside the tubing
Before experiment	White suspension	Brown /Yellow.
After experiment	<ul style="list-style-type: none"> - Blue/ Black /Blue – black colour observed - The level increased/size of Viking tubing increased. 	<ul style="list-style-type: none"> - Brown colour of iodine retained. - Level of iodine reduced.

b) – The extract inside the tubing contains starch, A blue – black was observed due to diffusion of iodine from the beaker across the Viking tubing membrane; since iodine has a low molecular size;

-

Iodine solution retained the brown colour because starch molecules in the extract are large; in size and could not pass through the pores of the viking tubing membrane; into the beaker.

- c) i) Gaseous exchange;
 ii) Transpiration;
 iii) Translocation of sugars;

2. a) i. Fungi
 ii. Reproduce asexually by budding or sporulation.
 b) i) M - Budding
 N – Sporulation
 ii) M – Yeast
 N – Rhizopus / Bread mould/mucor.,

- c) i) 8.7 cm
 ii) Linear Magnification = $\frac{\text{Linear dimension of the Image}}{\text{Linear dimension of actual object}}$
 Linear dimension of Image = 8.7 cm x 10000 μm = 8700 μm
 $X60 = \underline{8700} \mu\text{m}$
 x

$$x = \frac{8700}{60} \mu\text{m}$$

$$X = 1450 \mu\text{m}$$

- d) M – Used in baking Industry and brewing Industry.
 N – Causes decay of dead organisms releasing nutrients.
 Causes food decay.

3. a)
 b) A berry/ hesperidium.
 c) i) Animal dispersal.
 ii) – Succulent endocarp/Juicy endocarp.
 - Scented
 - Bright colour exocarp.
 - Seeds resistant to digestion.
 d)

Food Substance	Procedure	Observation	Conclusion
Reducing sugar	<ul style="list-style-type: none"> - Put test substance in the t. tube - Add benedict soln. - Boil 	- Colour changes to yellow/orange/red	- Reducing sugar present
Vit. C Ascorbic acid	<ul style="list-style-type: none"> - Put 2cm³ of given vol. of DCPIP in t. tube. - Add juice/test substance. 	- DCPIP decolourised	- Vit. C present.
Protein	<ul style="list-style-type: none"> - Put cm³ of juice in a t. tube. - Add 2 cm³ of NaOH - Add 2cm³ of CuSO₄ 	- No colour change	- Protein absent.

TRANS MARA DISTRICT

1. (a) P – Part of mammalian lung
 Q – Part of mammalian trachea
 (b) Respiration/breathing system
 (c) P- This is where diffusion/gaseous exchange occurs
 Q – Allows passage of air into the lungs
 (d) - It is elastic to allow stretching or expansion
 - Has numerous blood vessels to facilitate efficient transportation of gases
 - Presence of bronchiole for passes of air in and out

- Presence of pleural membrane that produces pleural fluid thus reducing friction

Presence of spongy air spaces /alveoli to increase the surface area for gaseous exchange

Q – Rigid, firm/hard rings of cartilage to prevent collapsing/keeps it open to allow passage of air.

- Presence of muscles between the rings/cartilage to allow for movement
- Mucus lining to trap foreign particles/filter air
- Cartilage rings are C-shaped to allow room for expansion
- To score a mark; the feature is tied to a function

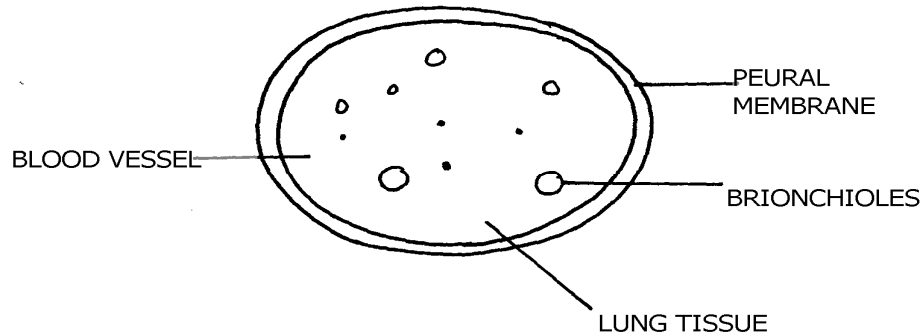

N/B- The score for the drawing – the drawing should have continuous outline (double) no shading and proportional in pencil.

- To score the label mark, the label line should not cross, no arrows

2. (a) specimen – R- Legume, S-Berm
 (b) (i)

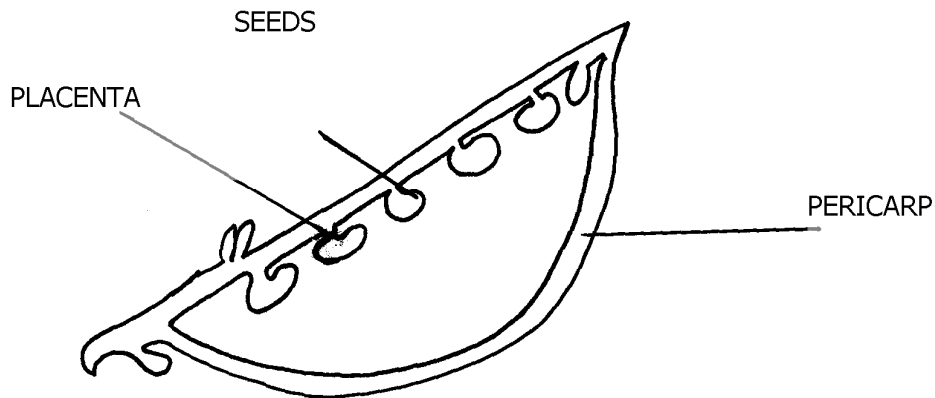

(ii) Magnification = $\frac{\text{length of drawing}}{\text{Length of specimen}}$
 $= \frac{X}{Y}$

(iii) Marginal placentation

(c) (i)

Specimen	Method of dispersal	Reasons
R	Self explosion	- has line of weakness

		- splitting line
S	Animal/man Reject: bird	- has brightly coloured skin to attract animal
		- succulent - has sweet smell scent

- (ii) S – Can be dispersed over a long distance hence low chances of overcrowding
 R- Dispersed over a short distance hence high chances of overcrowding

3. (a) (i) Phylum arthropoda

- (ii) – Have segmented bodies
 - Posses jointed limbs and appendages

(b) (i) K – cross – crustaceae

- Reasons – has two pairs of antennae
 - has forked appendage

(ii) N – class –chilopoda

Reason – All many segments with one pair of legs per segment

(c) (i) – Has two pairs of using for flying

- Has powerful (muscular) hind limb for hopping/jumping
 - Intermittent growth

(ii) – moulting/ecdyosome hormone

(d)- Enhance nutrient cycling/humus

- Aeration of soil

SOTIK DISTRICT

1. a)

<u>SPECIMEN</u>	<u>TYPE OF FRUIT</u>
P	Cypsella
Q	Berry
R	Legume
S	Cypsella

b) **R** has two lines of weaknesses (sutures) along which it splits; to release seeds by explosive mechanism;

Accept Self dopersal for explosive mechanism

Reject self explosion or self explosive mechanism

Agent = 1 mk, adaptation = 1 mk; reason = 1 mk

S is very small; with pappus; making it light; to float easily to be dispersed by wind;

Agent = wind 1 mk

Adaptation = 1 mk

Any one adaptive feature & explanation

Reason = 1 mk

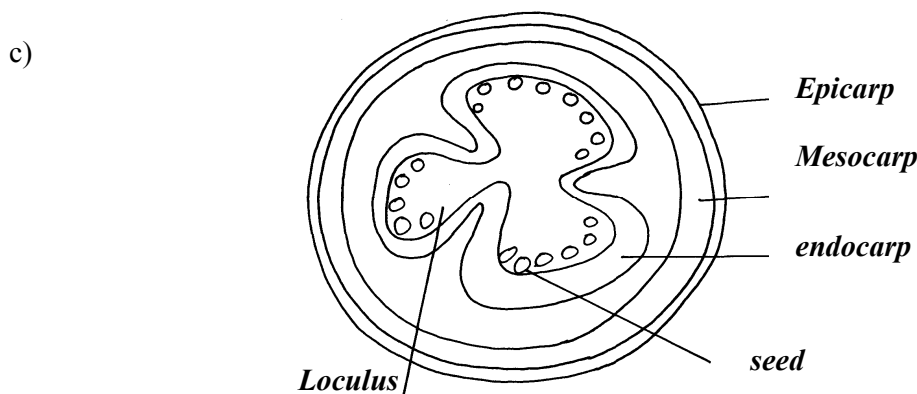

d) Axile placentation

2. a)

FOOD	PROCEDURE	OBSERVATION	CONCLUSION
Lipids	4cm ³ of food sample mixed with 4cm ³ of ethanol then add clean water(1 mk)	No change in colour	Absence of lipids
Reducing sugar	2cm ³ of food sample in mixed with 2cm ³ of Benedicts solution and heated in the hot water bath(1mk)	The colour changes from blue to brown 1mk	Presence of reducing sugar 1 mk
Ascorbic acid (Vitamin C)	2cm ³ of DCIP is put in a test tube. Add food sample droplisively (1mk)	The DCIP is decolorized (1mk)	Ascorbic acid (Vitamin C) present(1 mk)
Starch	2cm ³ of food sample placed in a test tube and four drops of iodine solution added (1 mk)	The colour of the solution turned brown 1 mk	Starch is absent 1 mk

b) Since a carbohydrate is present, maltase; acts on maltose; producing glucose; or lactase; acts on lactose; into galactose and glucose; i.e. enzymes in ileum; product;

c) Provides simple carbohydrates e.g. glucose which can be broken down in body cells to liberate energy; or it is a source of vitamin C which is necessary for proper development of epithelial tissues controlling scurvy;

OWITTE Any two fully explained answers

3. a) i) W – Aquatic (water)

ii) Z – Desert or semi- desert or dry land

b) i) Y- Flower

ii) Sexual reproduction

Reject reproductive alone

- c) Observable features apply i.e. has thick succulent stem; for storage of water; and respiratory; its leaves are reduced into spines; to lower the SA for transpiration; or for protection against herbivores