

Name Index Number

237/1 Candidate's Signature

GENERAL SCIENCE Date

Paper 1

Nov. 2016

2½ hours



THE KENYA NATIONAL EXAMINATIONS COUNCIL
Kenya Certificate of Secondary Education
GENERAL SCIENCE
Paper 1
2½ hours

Instructions to candidates

- (a) Write your name and index number in the spaces provided above.
- (b) Sign and write the date of examination in the spaces provided above.
- (c) This paper consists of **three** sections; **A, B and C**.
- (d) Answer **all** the questions in sections **A, B and C**.
- (e) All answers **must** be written in the spaces provided.
- (f) Silent non-programmable electronic calculators may be used.
- (g) This paper consists of **16 printed pages**.
- (h) Candidates should check the question paper to ascertain that all the pages are printed as indicated and that no questions are missing.
- (i) Candidates should answer the questions in English.

For Examiner's Use Only

Section	Question	Maximum Score	Candidate's Score
A	1-10	34	
B	11-21	33	
C	22-33	33	
Total Score			

SECTION A: BIOLOGY (34 marks)

Answer ALL the questions in the spaces provided.

1. State the **three** functions of human blood. (3 marks)

.....

.....

.....

2. (a) State **one** example of an organism in the kingdom protocista. (1 mark)

.....

- (b) Classify maize (*Zea mays*) into its first two largest taxonomic units. (2 marks)

.....

.....

3. Name the organelles observed under a light microscope in plant cells but not in animal cells. (2 marks)

.....

.....

4. Explain why a person in a poorly ventilated room with a burning charcoal stove may suffocate to death. (3 marks)

.....

.....

.....

5. The diagrams below illustrate a set-up from one student used, to demonstrate a certain physiological process and the result after two hours.

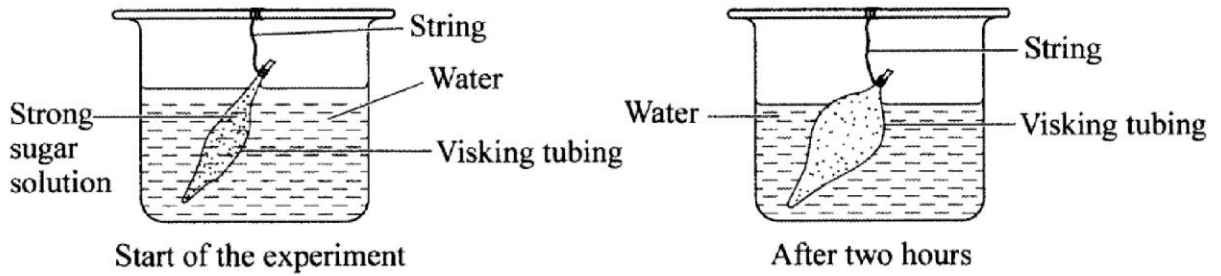

(a) Name the physiological process that was being demonstrated. (1 mark)

.....

(b) Explain the observation made after two hours. (3 marks)

.....
.....
.....

6. The diagram below represents part of a human organ.

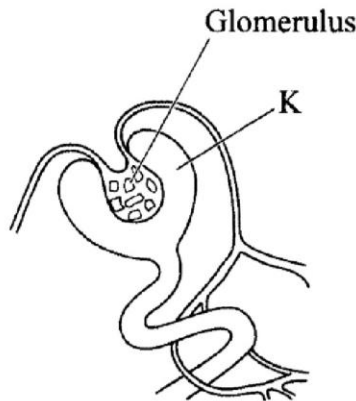

(a) Name the structure labelled K. (1 mark)

.....

(b) Explain why contents of K include non-excretory substances in a healthy person. (2 marks)

.....
.....



7. Form one students set up an experiment to demonstrate a physiological process as shown in the diagrams below.

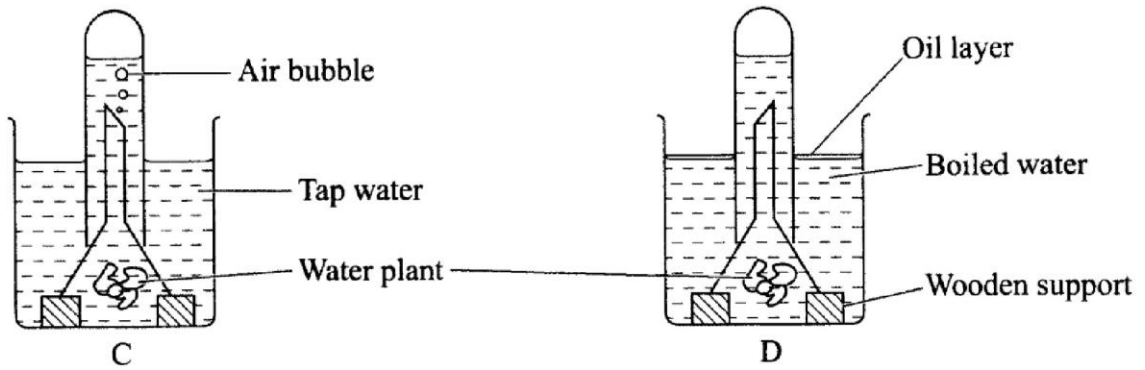

- (a) Why were bubbles **not** produced in the set-up labelled D? (2 marks)

.....

- (b) Name the gas collected in the set-up labelled C. (1 mark)

.....

8. (a) Name the branch of biology that deals with the study of animals. (1 mark)

.....

- (b) Give **two** reasons for classifying living organisms. (2 marks)

.....

9. (a) Differentiate between excretion and egestion. (2 marks)

.....
.....

- (b) How does the liver help to maintain a constant body temperature in human beings? (2 marks)

.....
.....

- (c) State **two** causes of kidney stones. (2 marks)

.....
.....

10. (a) Apart from thermoregulation, state **two** other roles of the skin in homeostasis. (2 marks)

.....
.....

- (b) How does amoeba maintain osmotic pressure when placed in a hypotonic solution? (2 marks)

.....
.....



SECTION B: CHEMISTRY (33 marks)

Answer *ALL* the questions in the spaces provided.

- 11.** The diagram below shows some changes in the physical states of matter. Study it and answer the questions that follow.

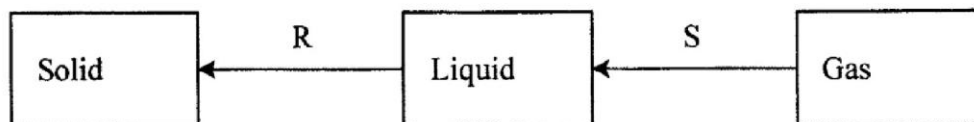

- (a) Name the changes represented by letters R and S. (2 marks)

R:

S:

- (b) Name the method used to separate coloured substances in a dye. (1 mark)

.....

- 12.** Magnesium burns in air with a bright flame.

- (a) State another observation made when magnesium burns in air. (1 mark)

.....

- (b) Write an equation for the reaction. (1 mark)

.....

- 13.** (a) Write a word equation for the reaction between dilute hydrochloric acid and calcium hydrogen carbonate. (1 mark)

.....

.....

- (b) Name the acid which is commonly used in car batteries. (1 mark)

.....

14. The diagram below shows the results obtained when wet iron filings in a gas jar inverted over water were left standing for 3 days.

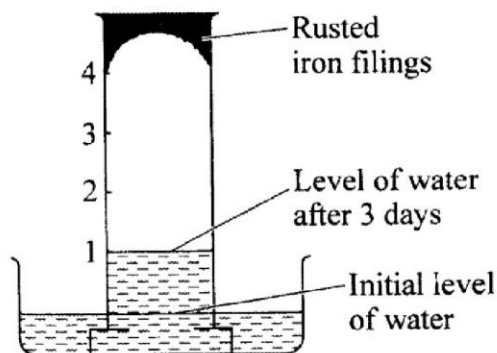

Given that the wet iron filings were in excess, what would be the effect of leaving the set up to stand for a further 3 days? (1 mark)

.....

15. The diagram below shows a reduction – oxidation process. Study it and answer the questions that follow.

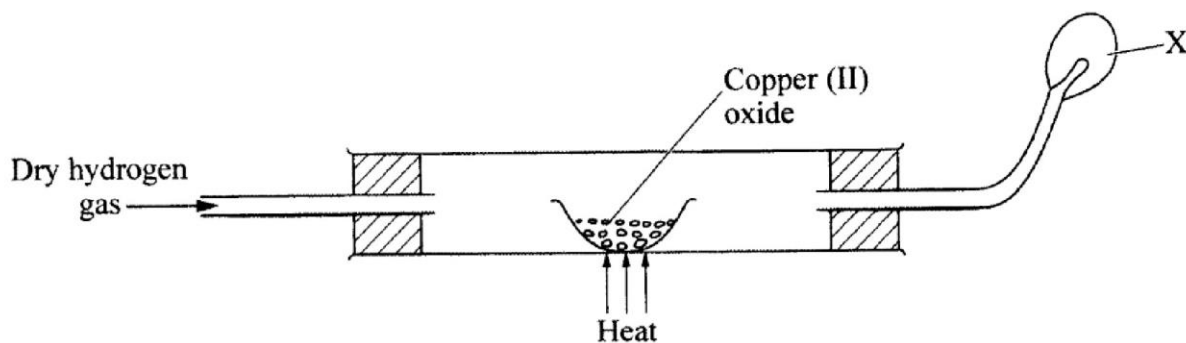

- (a) Write an equation for the reaction between dry hydrogen gas and hot copper (II) oxide. (1 mark)
-
- (b) In the process above, which substance undergoes oxidation? Explain. (2 marks)
-
-
- (c) Name the substance that burns at X? (1 mark)
-



16. The table below gives information about substances N, P, Q and R.

Substances	Melting point (°C)	Boiling point (°C)	Electrical conductivity when		
			Solid state	Molten	Dissolved in water
N	-115	-85	Poor	Poor	Good
P	801	1467	Poor	Good	Good
Q	98	890	Good	Good	Good
R	-117	78.5	Poor	Poor	Poor

(a) Select a substance that is likely to be hydrogen chloride. (1 mark)

.....

(b) Which letter represents a substance that is likely to have:

(i) metallic bonding. (1 mark)

(ii) ionic bonding. (1 mark)

17. State how the following substances conduct electricity.

(a) Molten calcium chloride. (1 mark)

.....

(b) Graphite. (1 mark)

.....

18. (a) State the purpose of the pH scale. (1 mark)

.....

(b) Hydrochloric acid is a strong acid. Explain the meaning of a strong acid. (1 mark)

.....

(c) Dilute hydrochloric acid was reacted with solid calcium carbonate in a test tube. Write a balanced chemical equation for the reaction. (1 mark)

.....

- (d) Give **two** disadvantages of washing clothes in hard water using soapy detergents. (2 marks)

.....

.....

19. The diagram below illustrates an experiment where dry hydrogen gas is passed over heated magnesium oxide.

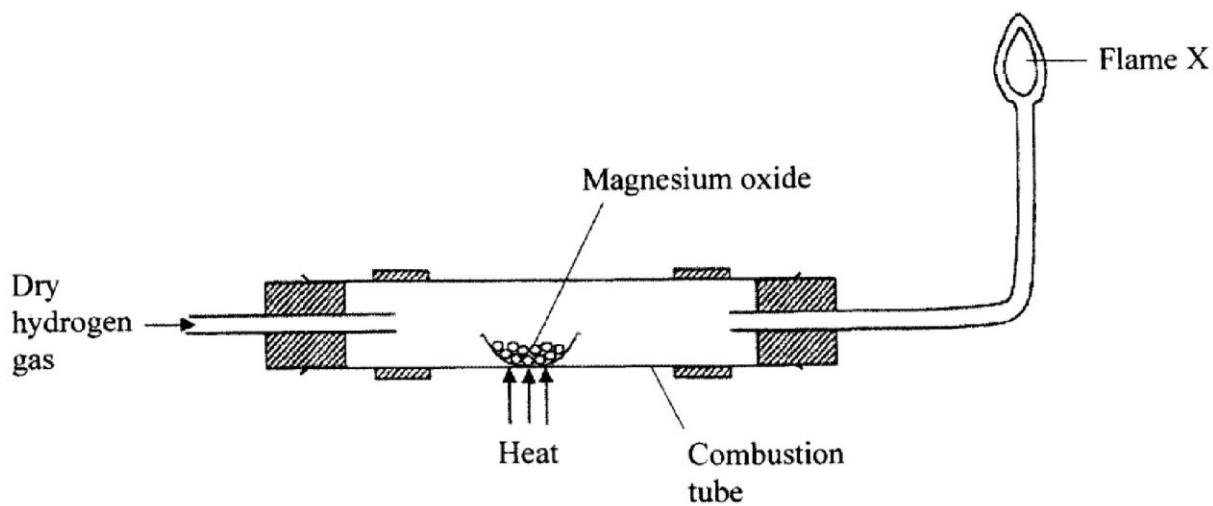

- (a) State the observation that is made in the combustion tube. (1 mark)
-
- (b) Explain the observation made in (a) above. (1 mark)
-
- (c) What substance burns at flame X? (1 mark)
-

20. (a) Name the type of reaction that occurs when a solution of lead (II) nitrate is added to a solution of sodium sulphate (in a boiling tube). (1 mark)
-



- (b) Write a balanced equation for the reaction that occurs when crystals of sodium nitrate are heated in a test tube. (1 mark)

.....

- (c) Give the meaning of an acid salt. (1 mark)

.....

21. Three experiments were set up as shown below to investigate the conditions necessary for rusting to occur.

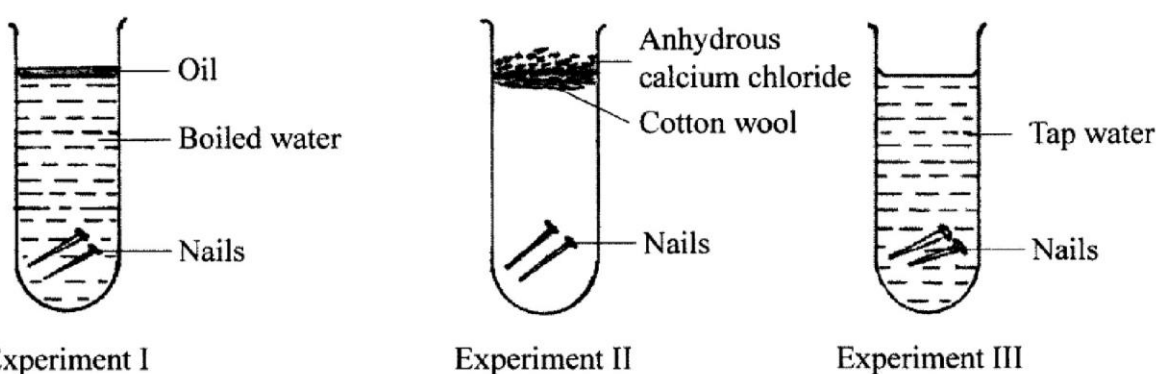

- (a) After three days, only the nails in experiment III had rusted. Why didn't rusting occur in experiment I and II?

I (1 mark)

II (1 mark)

- (b) What would be the effect of using salty water instead of tap water in experiment III? (1 mark)

.....

- (c) Complete the table below by stating the type of oxides formed when the following substances are burnt in air. (2 marks)

Substance	Type of oxide
Hydrogen	Neutral
Phosphorous	
Magnesium	

SECTION C: PHYSICS (33 marks)

Answer *ALL* the questions in the spaces provided.

22. When thirty (30) drops of a liquid were released from a burette, the liquid level changed from the 25 ml mark to the 40 ml mark. Determine the volume of each drop. (2 marks)

.....

.....

23. The figure below shows a uniform metre rule pivoted at the 60 cm mark. The rule is balanced when a 40 g mass is supported at the 90 cm mark.

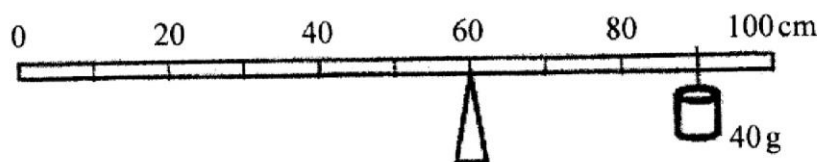

- (a) Show on the diagram the position of the centre of gravity of the metre rule. (1 mark)

.....

- (b) Determine the mass of the metre rule. (2 marks)

.....

24. A student in a room observed a beam of sunlight entering into the room from a hole on the roof. The student noted that dust particles illuminated by the beam were moving in random motion. Explain how this motion was caused. (2 marks)

.....

.....



25. (a) Define the term temperature. (1 mark)

.....

- (b) The figure below shows an electric iron box in which a brass-invar bimetallic strip is used to control the temperature.

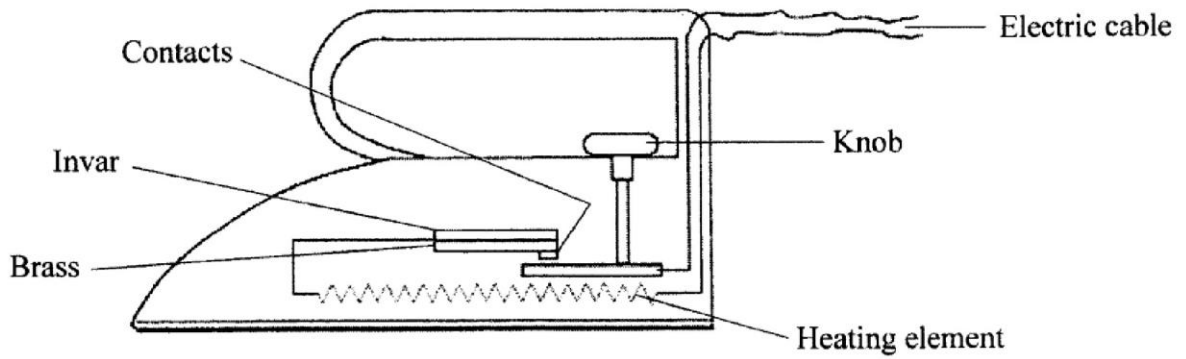

Given that brass expands more than invar, describe how the bimetallic strip controls the temperature of the iron box. (2 marks)

.....

.....

26. The figure below shows a crystal of potassium permanganate at the bottom of a beaker containing some water.

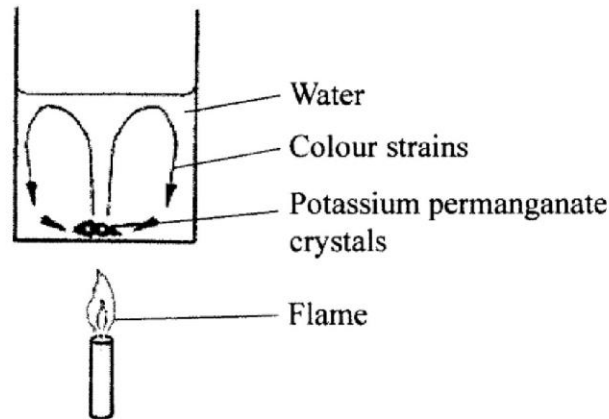

It is observed that when the beaker is heated from the bottom, strains of colour rise up from the crystal and curve out as shown. Explain the observation. (3 marks)

.....

.....

.....

.....

27. The figure below shows a pin being pushed into a block of wood using a thumb.

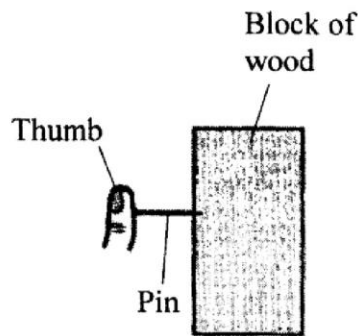

Explain why the pin penetrates the wood and not the thumb. (2 marks)

.....

.....

.....



28. The length of a spring is 20 cm. When it is used to support a mass of 0.4 kg its new length is 20.8 cm. Determine the spring constant (take acceleration due to gravity, $g = 10 \text{ ms}^{-2}$). (3 marks)

.....

.....

.....

.....

29. A stone is thrown vertically upwards. On the axes provided sketch the displacement-time graph for the motion of the stone from the time it is thrown to the time, t_f , when it reaches the maximum height. (2 marks)

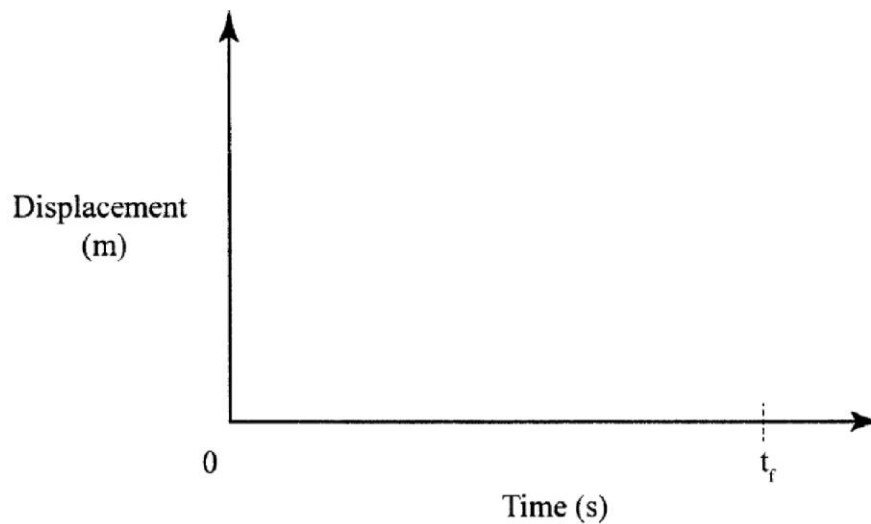

30. (a) A block of wood is pulled along a horizontal surface. State **one** factor that determines, the magnitude of the frictional force between the block and the surface. (1 mark)

.....

.....

- (b) The figure below shows a vertical glass tube containing a liquid. (1 mark)

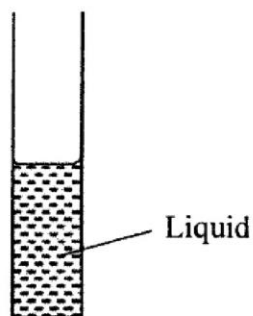

- (c) State the reason for the meniscus in terms of molecular forces. (2 marks)

.....

.....

.....

31. The figure below shows a metal block suspended from a spring balance and partially immersed in water.

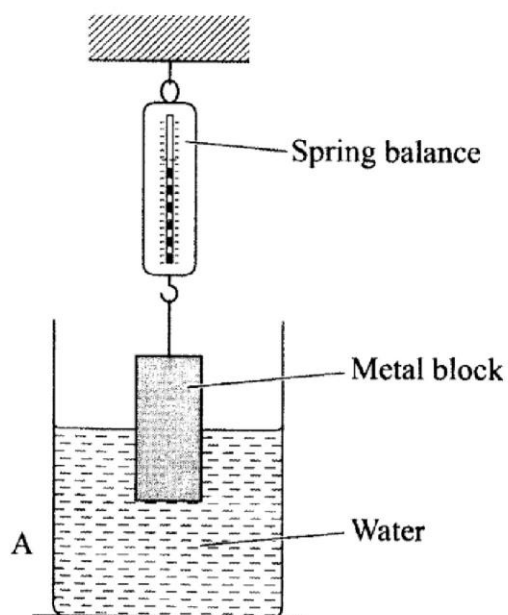

- (a) State what will be observed in the reading of the balance if the block is lowered further into the water. (1 mark)

.....

.....



- (b) Explain your answer in (a). (2 marks)

.....

.....

32. When a drop of water is placed on a clean metal surface it wets the surface. Explain this observation in terms of the forces involved. (3 marks)

.....

.....

.....

33. The figure below shows a uniform metre rule pivoted at the 20 cm mark and balanced by a weight of 4.5N.

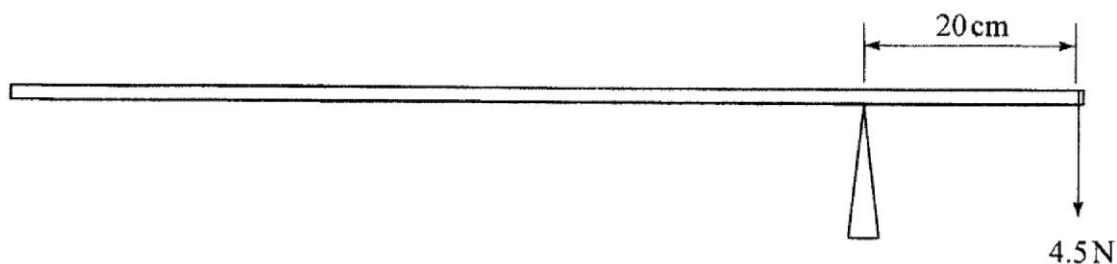

- Determine the weight of the metre rule. (3 marks)

.....

.....

.....

.....

THIS IS THE LAST PRINTED PAGE.