

Name..... Index No...../.....

232/1
PHYSICS
Paper 1
(THEORY)
Oct./Nov. 2015
2 hours

Candidate's Signature.....

Date.....



THE KENYA NATIONAL EXAMINATIONS COUNCIL

Kenya Certificate of Secondary Education

PHYSICS

Paper 1

(THEORY)

2 hours



02315170

Instructions to candidates

- (a) Write your name and index number in the spaces provided above.
- (b) Sign and write the date of examination in the spaces provided above.
- (c) This paper consists of two sections; A and B.
- (d) Answer *all* the questions in sections A and B in the spaces provided.
- (e) All working *must* be clearly shown.
- (f) Silent non programmable electronic calculators may be used.
- (g) This paper consists of 15 printed pages.
- (h) Candidates should check the question paper to ascertain that all the pages are printed as indicated and that no questions are missing.
- (i) Candidates should answer the questions in English.

For Examiner's Use Only

Section	Question	Maximum Score	Candidate's Score
A	1 - 13	25	
B	14	13	
	15	13	
	16	10	
	17	11	
	18	08	
Total Score		80	



SECTION A: (25 marks)

Answer ALL the questions in this section in the spaces provided.

- 1 **Figure 1** shows part of the main scale of a vernier callipers.

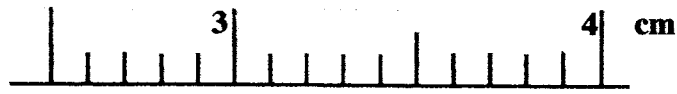

Figure 1

Insert the vernier scale to the main scale, to show a reading of 3.14 cm. (1 mark)

- 2 **Figure 2 (a)** shows the initial reading of a burette used to measure the volume of oil. After 50 drops of the oil were run out, the final reading was as shown in **Figure 2 (b)**

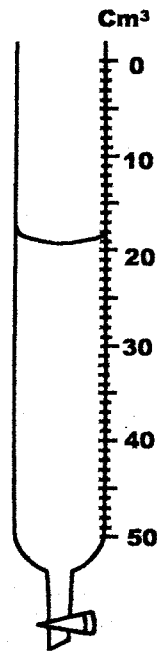

Figure 2 (a)

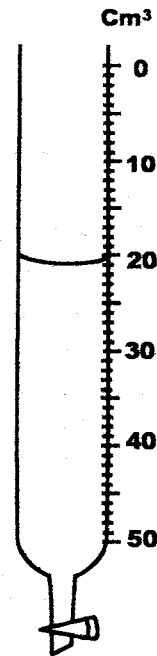

Figure 2 (b)

Determine the volume of one drop of oil. (2 marks)

.....

.....

.....

.....

- 3 A spring extends by 6 cm when supporting a mass of 0.06 kg on earth. When the spring is used to support the same mass on the moon, it extends by 1 cm. Determine the moon's gravitational strength. (Take gravitational field strength on earth as 10 Nkg^{-1}) (3 marks)

.....

.....

.....

.....

.....

.....

.....

- 4 State two factors that determine the pressure at a point in a liquid. (2 marks)

.....

.....

.....

.....

- 5 A student wearing sharp pointed heeled shoes is likely to damage a soft wooden floor. Explain. (2 marks)

.....

.....

.....

.....

- 6 Figure 3 shows the arrangement of molecules in the three states of matter.

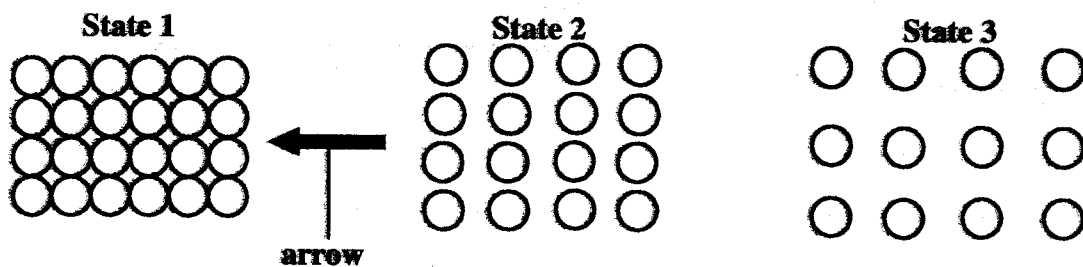

Figure 3

- (a) Name the process represented by the arrow. (1 mark)

.....

.....

- (b) State the reason for the arrangement of molecules in state 3. (1 mark)

.....

.....

- 7 Two containers **A** and **B** of equal dimensions but different metals are fitted with identical glass casings. The two containers initially at the same temperature are simultaneously filled with boiling water. It is observed that the glass casing on **A** breaks earlier than the one on **B**. Explain this observation. (2 marks)

.....

.....

.....

.....

- 8 **Figure 4** shows a uniform metal rod balanced at its centre by different forces.

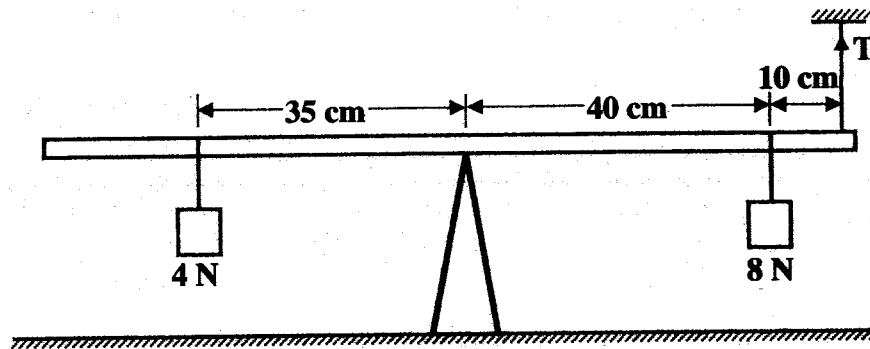

Figure 4

- Determine the value of **T**. (3 marks)

.....

.....

.....

.....

- 9 **Figure 5** shows air flowing through a pipe of different cross-sectional areas. Two pipes A and B are dipped into water.

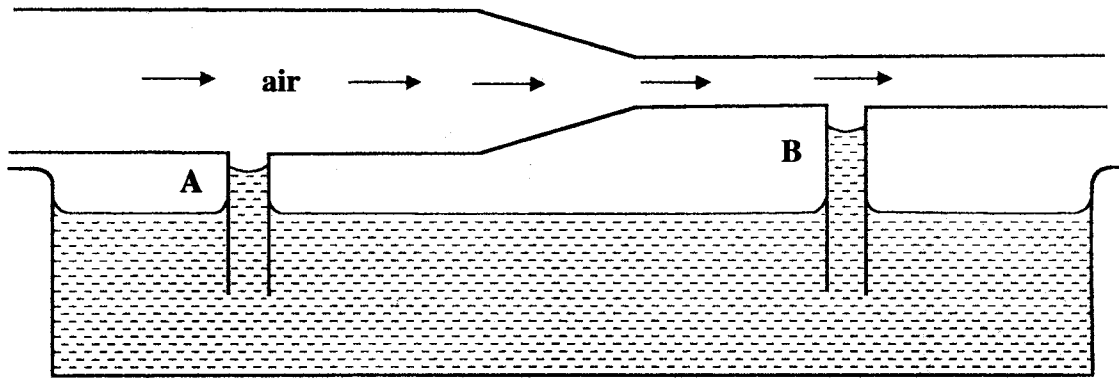

Figure 5

Explain the cause of the difference in the levels of water in the pipes A and B. (2 marks)

.....
.....
.....
.....

- 10 A balloon is filled with hydrogen gas and then released into the air. It is observed that as it rises higher into the air it expands. Explain why it expands. (2 marks)

.....
.....
.....
.....

- 11 A person carrying a heavy luggage using one hand leans away from the luggage. State the reason for this. (1 mark)

.....
.....

12 **Figure 6** shows a glass tube with water fitted with two identical thermometers **A** and **B**. It is heated as shown.

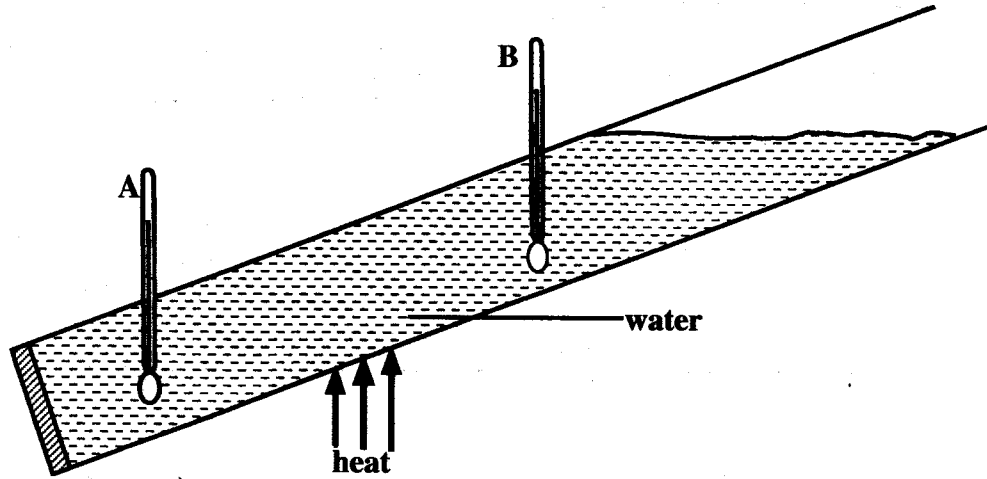

Figure 6

State with a reason which one of the two thermometers shows a higher temperature.

(2 marks)

.....
.....
.....
.....

13 Mechanics is one of the branches of physics. State what it deals with.

(1 mark)

.....
.....

SECTION B: (55 marks)

Answer ALL the questions in this section in the spaces provided.

- 14 (a) **Figure 7** (drawn to scale) shows a section of tape after passing through a ticker timer operated at a frequency of 50 Hz. The tape is attached to a trolley moving in the direction shown.

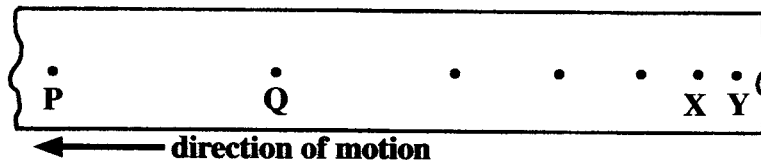

Figure 7

- (i) Determine the velocity between:

(I) P and Q; (4 marks)

.....
.....
.....
.....
.....
.....
.....
.....
.....

(II) X and Y. (2 marks)

.....
.....
.....
.....

- (ii) Determine the acceleration of the trolley. (3 marks)

.....

.....

.....

.....

.....

.....

- (b) Two bodies of masses 5 kg and 8 kg moving in the same direction with velocities 20 ms^{-1} and 15 ms^{-1} respectively collide inelastically. Determine the velocity of the bodies after the collision. (4 marks)

.....

.....

.....

.....

.....

.....

.....

.....

.....

.....

- 15 (a) **Figure 8** shows a 200 g mass placed on a frictionless surface and attached to a spring.

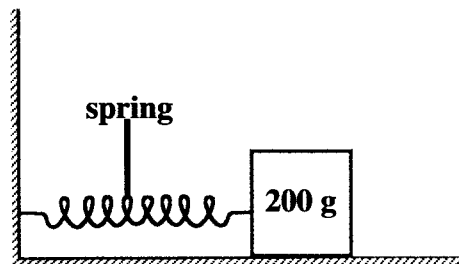

Figure 8

The spring is compressed and released. Given that the elastic potential energy of the compressed spring is 2.7×10^{-2} J, determine the maximum speed with which the block moves after it is released. (4 marks)

.....
.....
.....
.....
.....

(b) In a wheel and axle system, state the advantage of having a large wheel diameter compared to the axle diameter for a frictionless system. (1 mark)

.....
.....
.....
.....

(c) A body is released from a height **h**. Sketch a graph of potential energy against kinetic energy as the body falls to the ground. (2 marks)

- (d) **Figure 9** shows a hydraulic lift system. The radius of the small piston is 3 cm while that of the larger piston is 9 cm. A force of 90 N is applied to the smaller piston.

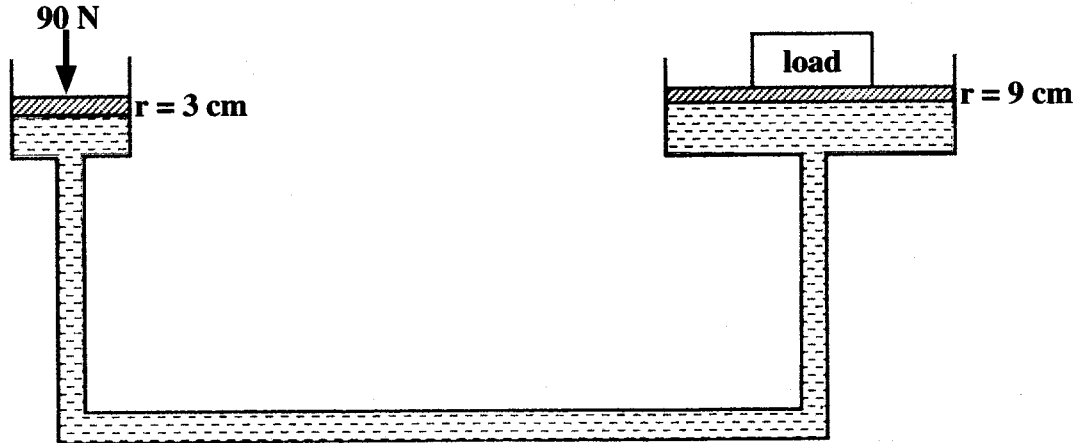

Figure 9

Determine the:

- (i) maximum load that can be lifted. (3 marks)

.....

.....

.....

.....

.....

.....

- (ii) efficiency of the system. (3 marks)

.....

.....

.....

.....

.....

.....

Kenya Certificate of Secondary Education, 2015

232/1

02315170

- 16 (a) **Figure 10** shows an **incomplete** set up that can be used in an experiment to determine the specific heat capacity of a solid of mass **m** by electrical method.

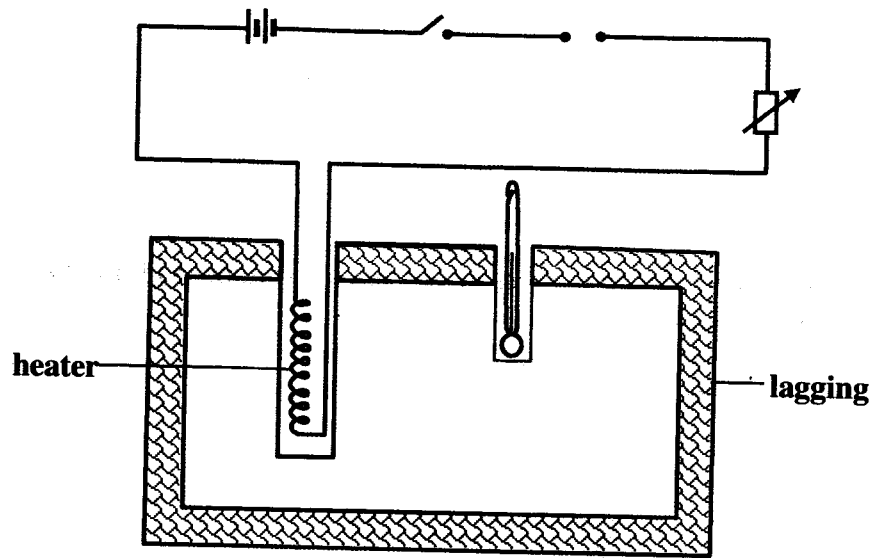

Figure 10

- (i) Complete the diagram by inserting the missing components for the experiment to work. (2 marks)
- (ii) Other than temperature, state **three** measurements that should be taken. (3 marks)

.....

.....

.....

.....

.....

.....

.....

- (iii) The final temperature was recorded as θ . Write an expression that can be used to determine the specific heat capacity of the solid. (2 marks)

.....

.....

.....

.....

- (b) State **three** ways of increasing the sensitivity of a liquid-in-glass thermometer. (3 marks)

.....

.....

.....

.....

- 17 (a) **Figure 11** shows a graph of pressure (**p**) against volume (**v**) for a fixed mass of a gas at constant temperature.

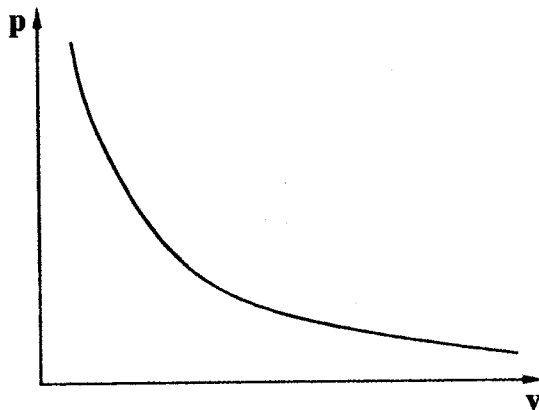

Figure 11

In the space provided, sketch the corresponding graph of **p** against $\frac{1}{v}$. (1 mark)

- (b) Explain the pressure law using the kinetic theory of gases. (3 marks)

.....

.....

.....

.....

.....

.....

- (c) 20 cm^3 of a gas exerts a pressure of 760 mmHg at 25°C . Determine the temperature of the gas when the pressure increases to 900 mmHg and the volume reduces to 15 cm^3 . (4 marks)

.....

.....

.....

.....

.....

.....

.....

.....

.....

.....

- (d) Figure 12 shows the path of a light ball projected horizontally.

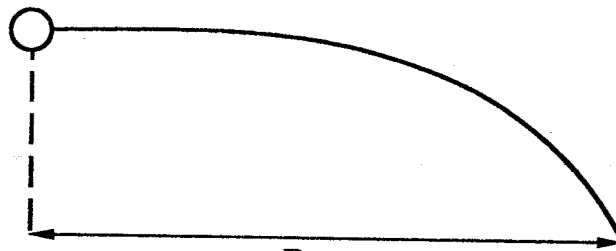

R
Figure 12

The ball is then made to spin in an anticlockwise direction as it moves:

- (i) on the same axis, sketch the new path of the ball. (1 mark)
- (ii) explain how the ball attains the new path. (2 marks)

.....

.....

.....

.....

18 (a) Figure 13 shows a pendulum bob suspended by a thread moving in a horizontal circle.

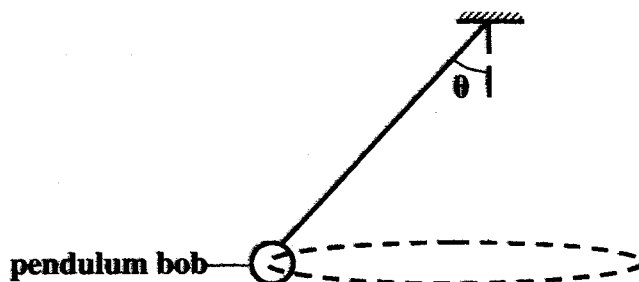

Figure 13

- (i) Name two forces acting on the pendulum bob as it moves. (2 marks)
- (ii) State what happens to each of the forces when the angular velocity of the pendulum bob is increased. (2 marks)

.....

.....

.....

.....

.....

.....

.....

.....

(iii) State **two** applications of uniform circular motion in daily life. (2 marks)

.....

.....

.....

.....

(b) **Figure 14** shows a block floating in water.

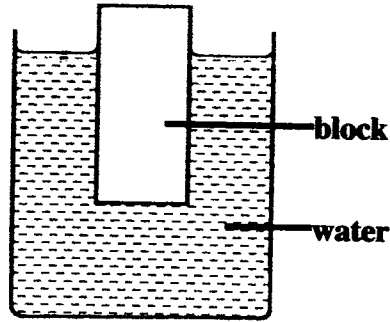

Figure 14

When the water is heated; it is observed that the block sinks further. Explain this observation. (2 marks)

.....

.....

.....

THIS IS THE LAST PRINTED PAGE.

Kenya Certificate of Secondary Education, 2015

232/1

02315170

Name..... Index Number...../.....

232/2
PHYSICS
Paper 2
Oct./Nov. 2015
2 hours

Candidate's Signature.....

Date.....



02315180

THE KENYA NATIONAL EXAMINATIONS COUNCIL
Kenya Certificate of Secondary Education
PHYSICS
Paper 2
2 hours

Instructions to candidates

- (a) Write your name and index number in the spaces provided above.
- (b) Sign and write the date of examination in the spaces provided above.
- (c) This paper consists of **two** sections: **A** and **B**.
- (d) Answer **all** the questions in sections **A** and **B** in the spaces provided.
- (e) All working **must** be clearly shown in the spaces provided in this booklet.
- (f) Non programmable silent electronic calculators may be used.
- (g) This paper consists of **12** printed pages.
- (h) Candidates should check the question paper to ascertain that all the pages are printed as indicated and that no questions are missing.
- (i) Candidates should answer the questions in English.

For Examiner's Use Only

Section	Question	Maximum Score	Candidate's Score
A	1 - 13	25	
	14	10	
B	15	9	
	16	12	
	17	11	
	18	13	
TOTAL		80	



SECTION A: (25 marks)

Answer all the questions in this section in the spaces provided.

- 1 **Figure 1** shows three mirrors arranged at right angles to each other. A ray of light is incident on one of the mirrors.

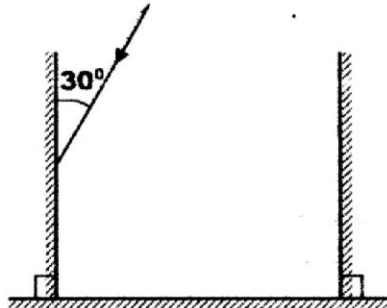

Figure 1

Complete the diagram to show the path of the ray after reflection on each of the mirrors.

(3 marks)

- 2 It is observed that when a charged body is brought near the cap of a positively charged electroscope, the divergence of the leaf increases. State the type of charge on the body.

(1 mark)

.....

- 3 State the reason for topping up a lead - acid accumulator with distilled water.

(1 mark)

.....

.....

.....

- 4 **Figure 2** shows a soft iron bar AB placed in a coil near a freely suspended magnet.

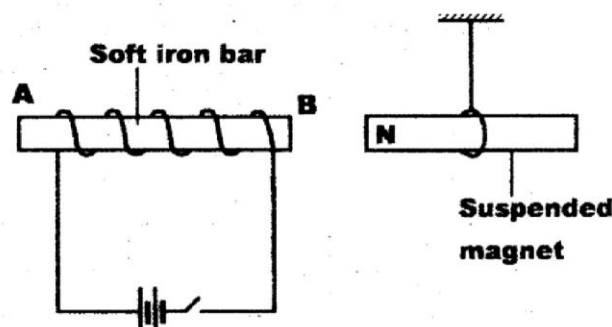

Figure 2

Explain the observation made when the switch is closed.

(2 marks)

.....
.....
.....
.....

5 State the reason why a convex mirror is preferred over a plane mirror for use as a driving mirror. (1 mark)

.....
.....

6 State **two** ways in which the strength of an electromagnet can be increased. (2 marks)

.....
.....
.....
.....

7 State **two** differences between electromagnetic waves and mechanical waves. (2 marks)

.....
.....
.....
.....

8 **Figure 3** shows straight waves incident on a diverging lens placed in a ripple tank to reduce its depth.

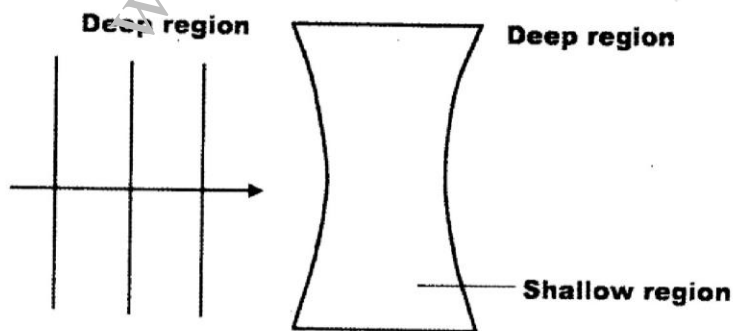

Figure 3

Complete the diagram to show the waves in both the shallow region and beyond the lens.

(2 marks)

- 9 A ship in an ocean sends out an ultra sound whose echo is received after 3 seconds. If the wavelength of the ultra sound in water is 7.5 cm, and the frequency of the transmitter is 20 kHz, determine the depth of the ocean. (3 marks)

.....
.....
.....
.....

- 10 A nail at the bottom of a beaker containing glycerine appears to be 6.8 cm below the surface of glycerine. Determine the height of the column of glycerine in the beaker. (take the refractive index of glycerine as 1.47) (3 marks)

.....
.....
.....
.....
.....
.....
.....
.....
.....
.....

- 11 State **one** application of thermionic emission. (1 mark)

.....
.....
.....
.....

- 12 **Figure 4** shows a cathode ray entering into a region between two charged plates.

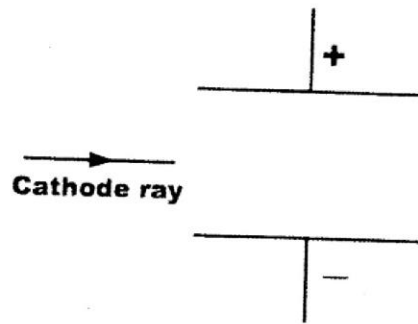

Figure 4

- Complete the diagram to show the path of the ray in the field. (1 mark)
- 13 When a transformer is connected to an ac source, the output voltage is found to be 24 V. If the power input is 200 W, determine the output current. (*Assume the transformer is 100% efficient*). (3 marks)

.....

.....

.....

.....

SECTION B: (55 marks)

Answer all the questions in this section in the spaces provided.

- 14** (a) State **two** factors that affect photoelectric emission. (2 marks)

.....
.....
.....

- (b) Light of wavelength $4.3 \times 10^{-7} \text{ m}$ is incident on two different metal surfaces, nickel and potassium. (Take speed of light as $3.0 \times 10^8 \text{ ms}^{-1}$ and planks constant h as $6.63 \times 10^{-34} \text{ Js}$).

- (i) Determine the energy of the incident radiation. (3 marks)

.....
.....
.....

- (ii) If the work function of nickel is $8.0 \times 10^{-19} \text{ J}$ and that of potassium is $3.68 \times 10^{-19} \text{ J}$, state with a reason from which of the two metals the given light will eject electrons. (2 marks)

.....
.....
.....

- (iii) Determine the velocity of the emitted electrons from the metal surface in b(ii). (Take the mass of an electron as $9.1 \times 10^{-31} \text{ kg}$). (3 marks)

.....
.....
.....

15 (a) State **two** factors that determine the resistance of a metallic conductor. (2 marks)

.....
.....
.....

(b) Explain how a fuse safeguards electrical appliances against excessive currents. (2 marks)

.....
.....
.....

(c) A hair dryer is rated 2.5 kW, 240 V.

(i) Determine whether a 10 A fuse may be suitable for the hair dryer. (3 marks)

.....
.....
.....

(ii) Determine the cost of using the hair dryer for 3 hours if the cost of electricity is Ksh 0.80 per kilowatt hour. (2 marks)

.....
.....
.....

- 16 (a) It is observed that alpha (α) particles have a lower penetrating power than beta (β) particles. Explain this observation. (2 marks)

.....
.....
.....
.....
.....

- (b) A radioactive substance has a half life of 12 years. Determine the time it would take to decay to 12.5% of its original value. (2 marks)

.....
.....
.....
.....
.....

- (c) A Geiger Müller (GM) tube is used for detecting radiations from a radioactive source. State the function of:

(i) the mica window; (1 mark)

.....
.....

(ii) bromine gas in the tube. (1 mark)

.....
.....

(d) (i) In a diffusion chamber, explain why some of the tracks formed are observed to be;

(I) Short, (2 marks)

.....
.....
.....

(II) Straight. (2 marks)

.....
.....
.....

(ii) State **two** advantages of using a GM tube instead of a diffusion cloud chamber to detect radiations from radioactive substances. (2 marks)

.....
.....
.....
.....

17 (a) State **three** factors that affect the capacitance of a parallel plate capacitor. (3 marks)

.....
.....
.....
.....
.....
.....

(b) **Figure 5** shows the circuit used to charge a capacitor C.

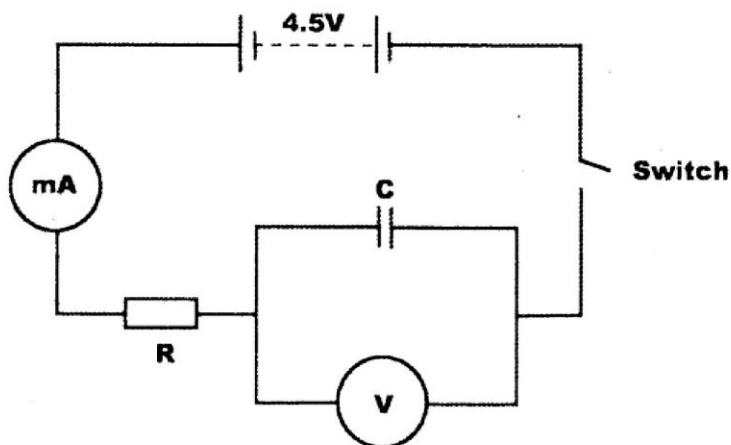

Figure 5

(i) State what would be observed on the following when the switch is closed:

(I) the milliammeter; (1 mark)

.....

.....

(II) the voltmeter; (1 mark)

.....

.....

(ii) Explain how the capacitor gets charged. (3 marks)

.....

.....

.....

.....

(iii) State the purpose of the resistor R. (1 mark)

.....

.....

- (iv) On the axes provided, sketch the graph of voltage (V) against time (t). (2 marks)

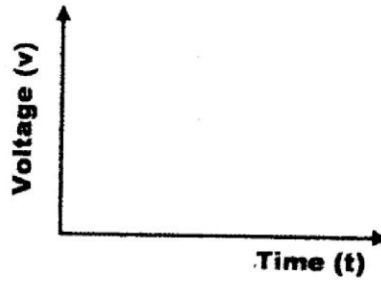

- 18 (a) Three resistors of resistance $2\ \Omega$, $3\ \Omega$ and $4\ \Omega$ are to be connected to a cell such that they have the least effective resistance.

- (i) Draw a circuit diagram to show how they can be connected to achieve this. (2 marks)

- (ii) Determine the least effective resistance of the three resistors. (3 marks)

.....

.....

.....

.....

- (b) A real object of height 1 cm placed 50 mm from a converging lens forms a virtual image 100 mm from the lens.

- (i) Determine the:
 (I) focal length of the lens; (3 marks)

.....

.....

- (II) magnification. (2 marks)

.....

.....

- (ii) On the grid provided draw to scale the ray diagram for the set up, to show how the image is formed. (3 marks)

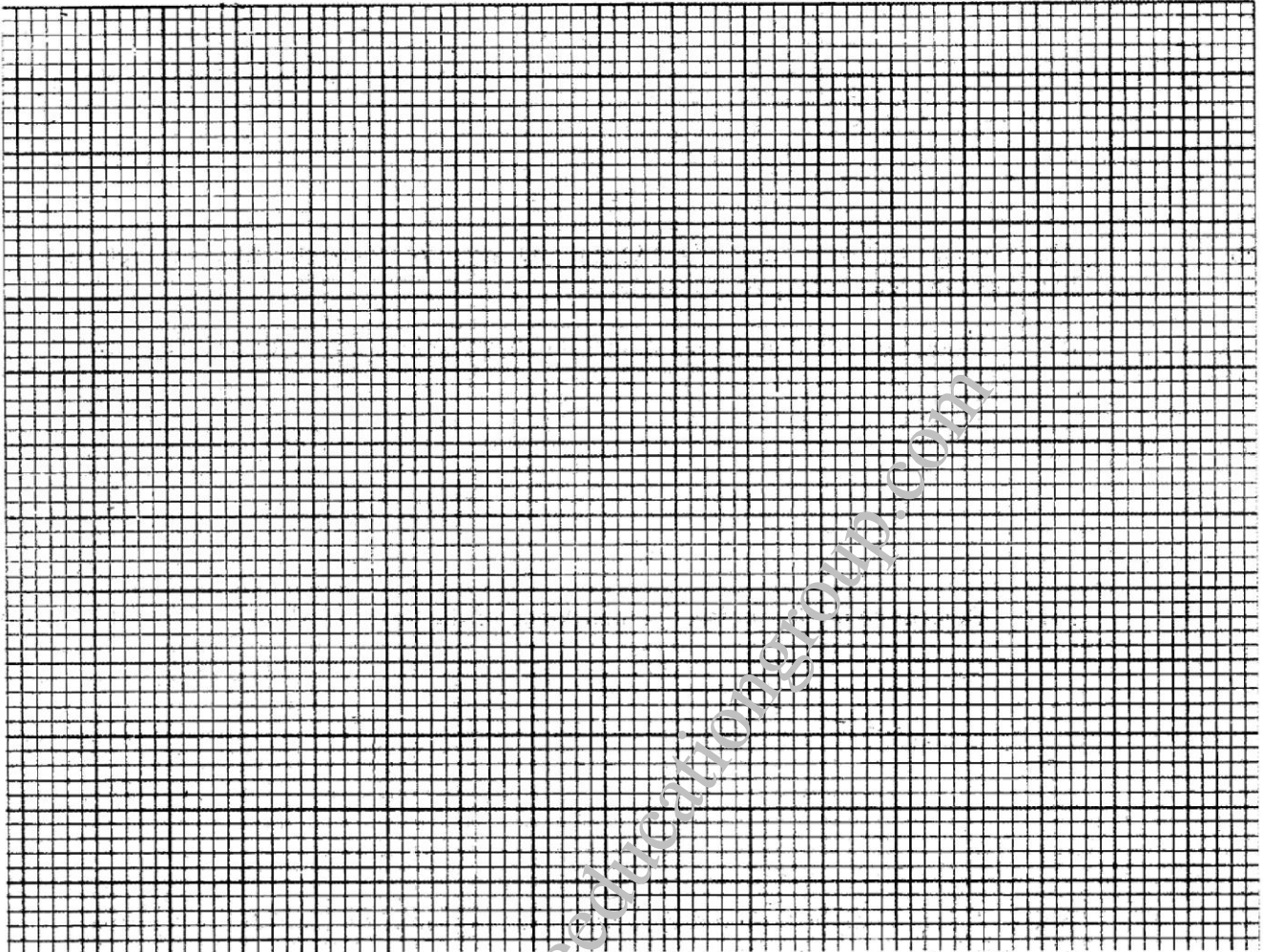

THIS IS THE LAST PRINTED PAGE.

Kenya Certificate of Secondary Education, 2015

232/2

02315180

915029

Name..... Index No...../.....

232/3
PHYSICS
(PRACTICAL)
Paper 3
Oct./Nov. 2015
 2 $\frac{1}{2}$ hours

Candidate's Signature.....

Date.....



THE KENYA NATIONAL EXAMINATIONS COUNCIL
Kenya Certificate of Secondary Education
PHYSICS
(PRACTICAL)
Paper 3
 2 $\frac{1}{2}$ hours

02315190

Instructions to candidates

- (a) Write your name and index number in the spaces provided above.
- (b) Sign and write the date of examination in the spaces provided above.
- (c) Answer **all** the questions in the spaces provided in the question paper.
- (d) You are supposed to spend the first 15 minutes of the 2 $\frac{1}{2}$ hours allowed for this paper reading the whole paper carefully before commencing your work.
- (e) Marks are given for a clear record of the observations actually made, their suitability, accuracy and the use made of them.
- (f) Candidates are advised to record their observations as soon as they are made.
- (g) **Non-programmable** silent electronic calculators may be used.
- (h) **This paper consists of 11 printed pages.**
- (i) **Candidates should check the question paper to ascertain that all the pages are printed as indicated and that no questions are missing.**
- (j) **Candidates should answer the questions in English.**

For Examiner's Use Only

Question 1	a	d	e	f	g	h	i	j	m	n	o	Total
Maximum Score	1	1	1	1	1	2	2	2	4	1	4	<input type="text"/>
Candidate's Score												<input type="text"/>

Question 2	a	b	d	e	f(i)	f(ii)	g	Total
Maximum Score	1	1	7	3	3	3	2	<input type="text"/>
Candidate's Score								<input type="text"/>

Grand Total



Question one

You are provided with the following:

- a micrometer screw gauge (to be shared)
- a vernier calliper (to be shared)
- glass tube
- a wire labelled **M**
- some sellotape
- one 50 g mass
- some masses (totalling 40 g)
- a meter rule
- 100 ml beaker
- a stand boss and clamp
- a stop watch
- a source of light
- a screen
- some water
- a measuring cylinder

PART A

Proceed as follows:

- (a) Using a micrometer screw gauge, measure and record the diameter of the wire labelled **M**.
(1 mark)

d = mm

d = m.

- (b) Using wire **M**, make a spring as follows:

- (i) Use some sellotape to fix one end of the wire **M** (about 2.5 cm) along the glass tube;
- (ii) Hold firmly the part of the wire under the tape with one hand. Use the other hand to wind 30 turns as closely and tightly as possible. (*see figure 1*)

Kenya Certificate of Secondary Education, 2015

232/3

02315190

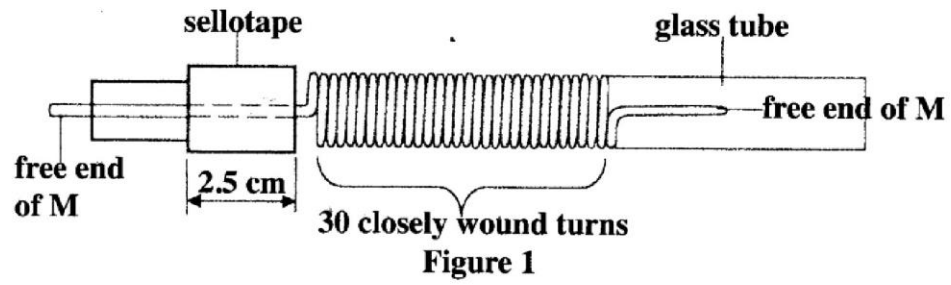

- (c) Remove the sellotape and release the spring from the tube.
 (The spring will slightly unwind and some turns will disappear)
 Bend the free ends as shown in figure 2.

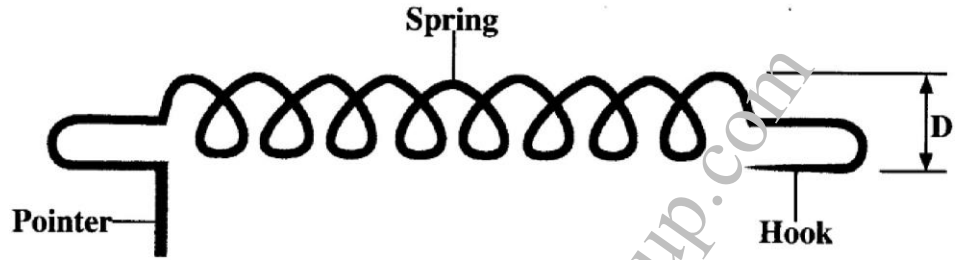

Figure 2

- (d) Using a vernier callipers, measure and record the external diameter D of the spring.

(1 mark)

$D = \dots\dots\dots$ cm

$D = \dots\dots\dots$ m.

- (e) Suspend the spring and a 50 g mass from a retort stand as shown in figure 3.

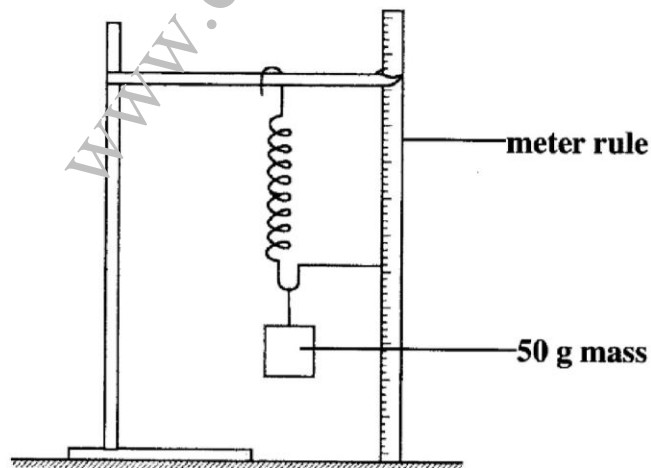

Figure 3

Count and record the number of turns **N** of the suspended spring. (1 mark)

N =

(f) Add 40 g to the 50 g mass and record the extension **X** of the spring due to the 40 g. (1 mark)

X = cm

X = m

(g) Determine **c** given that (1 mark)

$$c = \frac{0.4}{X}$$

.....

(h) Determine **n** given that (2 marks)

$$c = \frac{nd^4}{8ND^3}$$

.....

(i) With the spring still loaded with the 90 g, pull the lower mass slightly downwards and let go so that the mass oscillates vertically. Record the time **t** for 20 oscillations. Hence determine the period **T**.

t = (s) (1 mark)

T = (s) (1 mark)

- (j) Determine Z given that

$$T = 2\pi\sqrt{\frac{m}{Z}}$$

where m is the mass in kg on the spring.

(2 marks)

.....

.....

.....

.....

www.eeducationgroup.com

PART B

Proceed as follows:

- (k) Place the 100 ml beaker on a meter rule and pour 80 cm³ of water into it. Arrange a lamp (source of light) and a screen on either side of the beaker. (see figure 4)

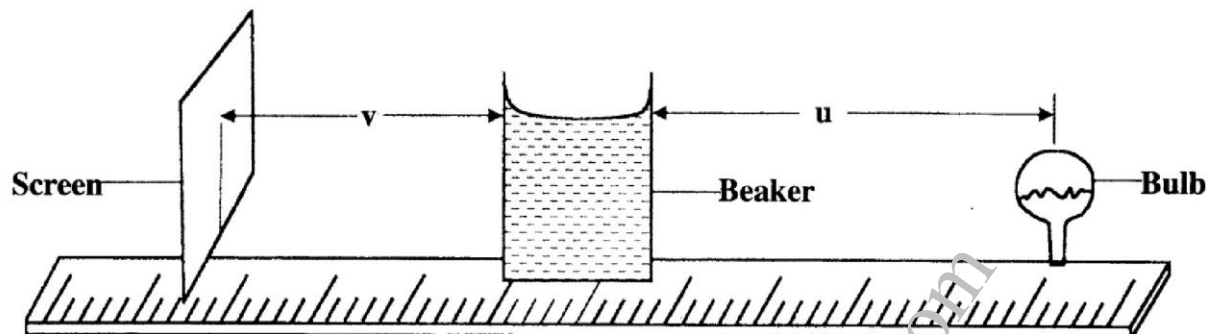

Figure 4

- (l) Adjust the position of the lamp on the metre rule so that its centre is a distance $u = 12$ cm from the beaker. Switch on the light. Adjust the position of the screen until a well focused vertical line (*the image of filament*) is formed on the screen. Measure and record in **table 1** the image distance V between the screen and the beaker.
- (m) Repeat part (l) for other values of u shown in **table 1** and complete the table.

Table 1

Distance u (cm)	12	16	20
Distance V (cm)			
$y = \frac{uv}{u+v}$			

(4 marks)

- (n) Determine m , the mean value of y using the values in **table 1**.

(1 mark)

$m = \dots\dots\dots$

- (o) (i) With the meter rule outside the beaker, measure the height **h** of the water meniscus above the bench. (1 mark)

h = cm

- (ii) Determine the value of **P** given that (1 mark)

$$P = \frac{5}{\sqrt{h}}$$

- (iii) Hence determine the value of **f** given that $f = \frac{P}{2m} + 1$ to one decimal place. (2 marks)

.....

.....

.....

.....

.....

Question two

You are provided with the following:

- an ammeter
- a voltmeter
- two cells (size D)
- a cell holder
- a switch
- a wire labelled **L** mounted on a millimetre scale
- a micrometer screw gauge (to be shared)
- six connecting wires at least four with crocodile clips

Proceed as follows:

- (a) Using a micrometer screw gauge, measure and record the diameter **d** of the wire **L**. (1 mark)

d = mm

d = m.

- (b) Place the two cells **in series** in the cell holder and use the voltmeter to measure the total electromotive force (emf) **E₀** of the battery. (1 mark)

E₀ = V.

- (c) Starting with the switch open, connect the circuit as shown in **figure 5**. **P** and **Q** are points on the wire **L** such that **PQ** is 60 cm. (*PQ should remain 60 cm throughout the experiment*) **N** is a point on the wire such that **PN** is 10 cm (0.1 m).

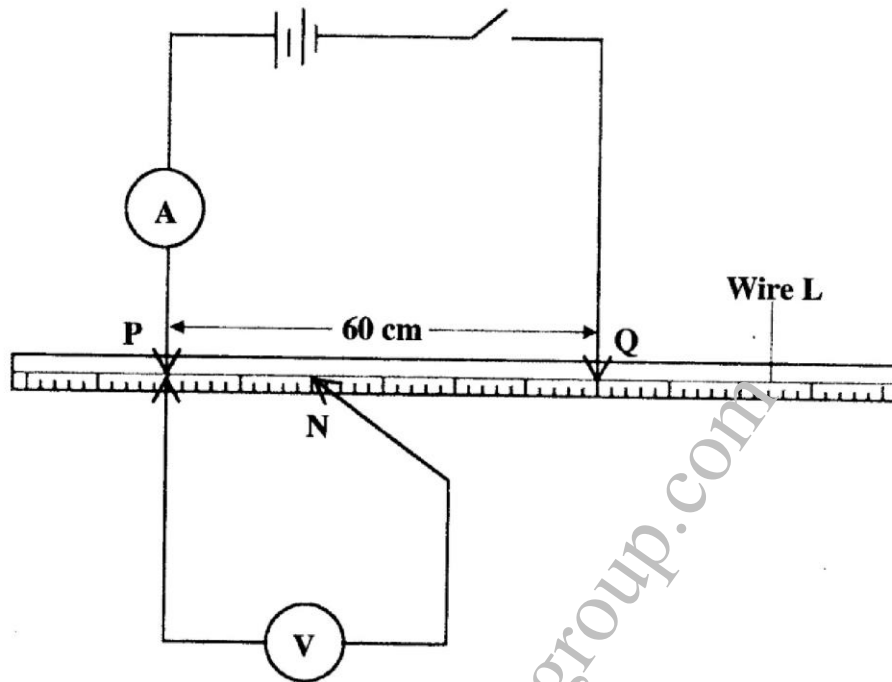

Figure 5

- (d) (i) Close the switch and record the current I . (1 mark)
- $I = \dots\dots\dots$ A.
- (ii) Measure and record in **table 2** the potential difference across **PN**.
- (iii) Measure and record the potential difference across **PN** for the other values of **PN** shown in **table 2** and complete the table. (*The current is expected to remain constant*)
 Hint: *The switch should be closed only when reading the voltmeter.*

Table 2

Length PN (m)	0.1	0.2	0.3	0.4	0.5	0.6
p.d (V)						
Resistance ($\frac{V}{I}$) Ω						

(6 marks)

(e) On the grid provided, plot a graph of resistance (y-axis) against length.

(3 marks)

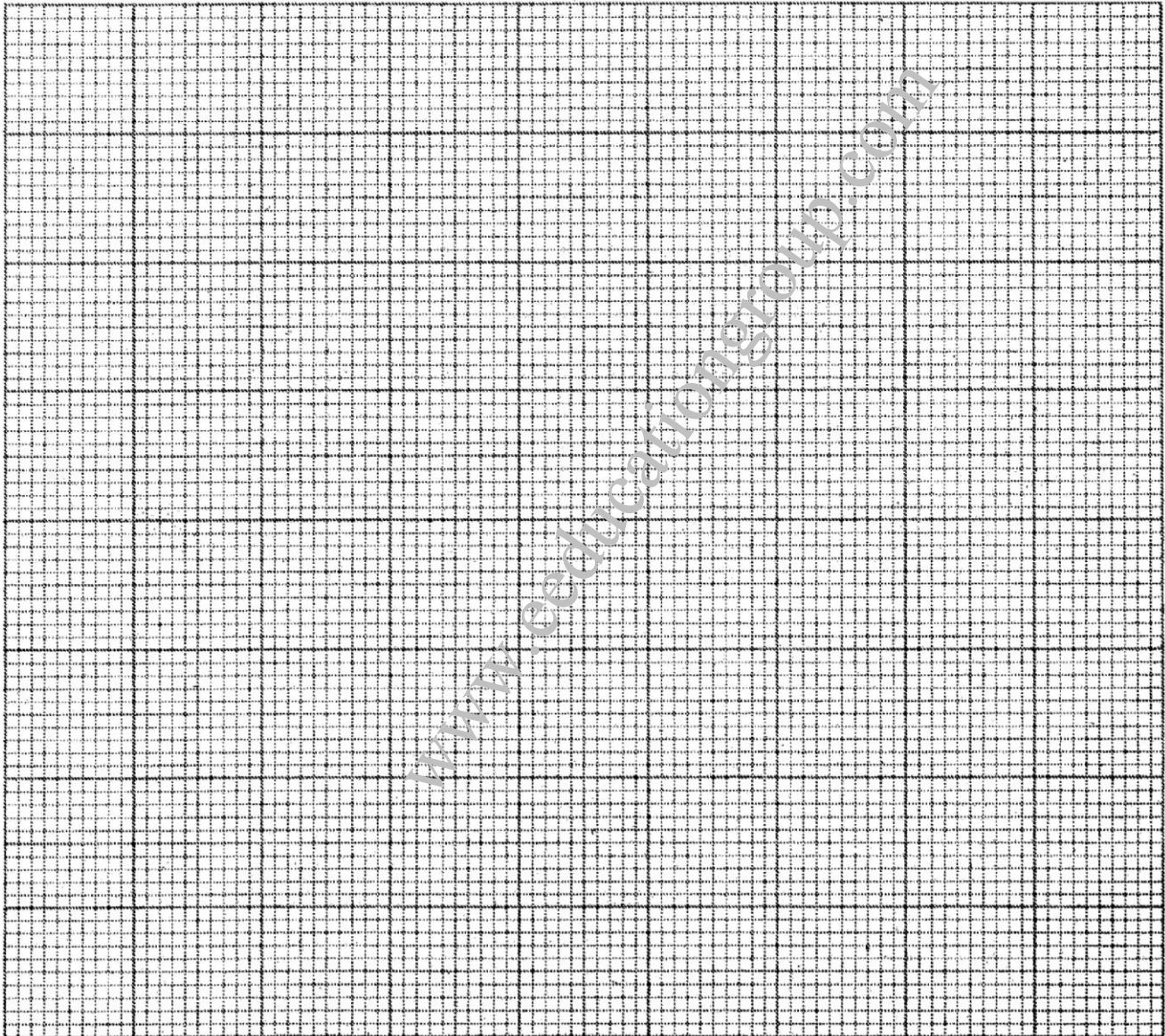

Kenya Certificate of Secondary Education, 2015

232/3

02315190

(f) From the graph, determine:

(i) the slope S and its units.

(3 marks)

.....

.....

.....

.....

.....

.....

(ii) the constant k and its units given that

$$S = \frac{4k}{\pi d^2}$$

(3 marks)

.....

.....

.....

.....

.....

.....

(g) Determine constant t given that

$$t = \frac{E_0 - V_n}{I}$$

where V_n is the p.d at PN = 0.6 m.

(2 marks)

.....

.....

.....

.....

THIS IS THE LAST PRINTED PAGE.

Kenya Certificate of Secondary Education, 2015

232/3

02315190